

DIGITAL PREDISTORTION OF HARDWARE IMPAIRMENTS FOR FULL-DUPLEX TRANSCEIVERS

Andrew C. M. Austin

Dept. of Electrical and Computer Engineering
The University of Auckland, New Zealand

Orion Afisiadis, Andreas Burg

Telecommunications Circuits Laboratory
EPFL, Lausanne, Switzerland

ABSTRACT

Digital predistortion is applied to account for all significant hardware impairments in a regeneration architecture full-duplex transceiver. Compared to a conventional regeneration architecture, where non-linearities are simply reconstructed for cancellation, by predistorting we avoid these components to achieve an improvement in both self-interference suppression and signal quality. A new set of predistortion basis functions is proposed for the cascade of baseband non-linearities, mixer IQ imbalance, and power amplifier non-linear memory effects. Experimental results on a hardware testbed operating in the 2.4 GHz ISM band show that an additional 14 dB analog suppression can be achieved using the proposed predistortion basis over a 20 MHz bandwidth (compared to the case without predistortion), leading to a total self-interference suppression of 71.5 dB.

Index Terms— Full-duplex, Non-linear predistortion

1. INTRODUCTION

Full-duplex is a novel approach that promises to double the spectral efficiency of a wireless link (compared to half-duplex) by allowing simultaneous transmission and reception in the same frequency band [1, 2, 3]. As the transmit signal is ‘known’ within the full-duplex transceiver, it is possible to generate an appropriate cancellation signal that will effectively suppress the self-interference coupled into the receiver chain. Ideally the self-interference is suppressed to (or below) the receiver noise-floor [4]. To avoid saturating the receiver RF components and analog-to-digital converter (ADC), the cancellation signal must be generated and applied in the RF/analog domain [4, 5]. To this end, there are two full-duplex architecture choices: *regeneration-based*, where a separate RF chain is used to synthesise the necessary RF cancellation signal directly from the digital baseband [2, 6, 7]; and *circuit-based*, where a replica of the transmitted signal is appropriately attenuated and phase-shifted via delay lines to produce the required RF cancellation signal, which is then coupled into the received signal [1, 3, 8].

This paper focuses on regeneration-based full-duplex systems, as these have practical advantages over RF circuit based

systems, including a reduced physical size, the ability to more rapidly adapt to changing channel conditions and better scalability for multiple-input multiple-output (MIMO) technology. However, as the cancellation signal is synthesised from the digital-baseband, regeneration-based systems are also more prone to the effects of transmitter and receiver hardware impairments. Straightforward analog/RF cancellation can only suppress components of the self-interference that are *linearly* proportional to delayed copies of the baseband transmitted signal. Suppression of non-linear effects can be achieved by reconstructing these non-linearities in the analog cancellation signal. Unfortunately, this reconstruction turns out to be extremely difficult since the RF components in the cancellation chain will also introduce additional (and independent) non-linear signal components. At ‘high’ transmit power levels, the non-linear components in the residual (after analog suppression) can have significant power. The high power of this residual often requires the sensitivity of the receiver to be reduced, thereby decreasing the effective signal-to-noise ratio. As an alternative to the reconstruction of non-linearities, previous research has examined the use of digital predistortion in full-duplex transceivers to compensate for power amplifier memory effects [7]. In this case an overall 13 dB improvement in the suppression was observed (compared to the case without predistortion). However, this improvement was achieved only in the digital stage, i.e., no additional suppression in the analog stage was observed.

Given the limited analog suppression that can be practically achieved, existing regeneration-based (and circuit-based) full-duplex systems use additional digital cancellation stages to remove the non-linear components in the residual [1, 3, 2, 9]. Unfortunately, accurate reconstruction of these components requires a very complex digital cancellation stage [6]. In particular, the self-interference signal becomes very difficult to model, as it contains the cascaded effect of multiple hardware impairments, e.g., baseband non-linearities introduced by the DACs [6]; IQ imbalance arising from the mixers [10]; sampling jitter [11]; phase-noise [12, 13]; and memory effects of the non-linear power amplifiers [7, 10, 14, 15]. While capturing the impact of all of these components requires high-order polynomials, it

is important to avoid over-fitting the cancellation model, as noise will always be present in the measurements.

Contributions: In this paper we propose to use predistortion together with signal regeneration to compensate for all significant hardware impairments in a full-duplex transceiver. Since the predistorted passband self-interference signal is only a linear copy of the baseband transmit signal, a predistorted analog cancellation stage *alone* is sufficient to suppress the self-interference. In addition to the introduction of the concept of predistortion based self-interference cancellation, we also extend the power amplifier predistortion basis functions developed in [7] to incorporate the cascade of IQ imbalance, digital-to-analog converter (DAC) non-linearity and power amplifier memory effects. We validate both our proposed predistortion based full-duplex cancellation architecture and the extended non-linearity model on a wideband full-duplex over-the-air hardware testbed operating in the 2.4 GHz ISM band.

The paper is organised as follows. In Section 2, we briefly describe the predistortion based regeneration architecture for self-interference cancellation in full-duplex radios, and we outline mathematical models for the various hardware impairments present in a typical regeneration-based full-duplex transceiver. In Section 3, the theoretical models are validated with experimental measurements of the self-interference suppression achieved on an experimental full-duplex testbed. The paper is briefly concluded in Section 4.

2. APPLICATION OF DIGITAL PREDISTORTION TO FULL-DUPLEX TRANSCEIVERS

Fig. 1(a) shows the block diagram of a full-duplex transceiver, where the analog-self-interference signal is generated via a dedicated passband circuit. In comparison, Fig. 1(b) shows a regeneration architecture, where the cancellation signal is regenerated from the digital baseband using a separate RF chain. The self-interference ‘channel’ is sounded using a training frame. The response is used to compute the coefficients of the finite-impulse response (FIR) filter that produces the required cancellation signal [2, 6]. Only few hardware impairments can be included, as this process only suppresses linear signal components. Typically the analog suppression stage is followed by a digital cancellation stage to suppress the residual non-linear components. However, the (often) high analog residual signal necessitates reducing the receiver sensitivity to avoid saturation.

2.1. Characterisation of Hardware Impairments in Full-Duplex Transceivers

In this section we briefly outline the digital baseband mathematical models for the various hardware impairments present in the full-duplex transmitter depicted in Fig. 1(b). The baseband transmit signal $x(n)$ is comprised of a real and

imaginary component, which are up-converted using separate DACs and mixers. The DACs introduce baseband non-linearities, which manifest as both odd- and even-ordered harmonics (of the complex-valued baseband signal) in the real-valued passband transmitted signal [6]. Accordingly, the DAC non-linearities can be modelled in the baseband representation of the passband signal using a Taylor’s series expansion,

$$x_{\text{DAC}}(n) = \sum_{p=1}^{P_{\text{max}}} a_p \Re \{x(n)\}^p + j \sum_{p=1}^{P_{\text{max}}} b_p \Im \{x(n)\}^p, \quad (1)$$

where $\Re \{x(n)\}$ and $\Im \{x(n)\}$ are the real and imaginary components of the baseband transmit signal respectively. The coefficients a_p and b_p are the non-linear coefficients for the I- and Q-DACs respectively, and the expansion is truncated after P_{max} terms. IQ-imbalance arises due to inherent differences between the I- and Q-mixers. In the baseband the impact of this imbalance can be modelled as an additional complex conjugate term [16, pp. 71–79]

$$x_{\text{IQ}}(n) = \alpha x_{\text{DAC}}(n) + \beta x_{\text{DAC}}^*(n), \quad (2)$$

where x_{DAC}^* represents the complex-conjugate of x_{DAC} , and α and β are coefficients that can be derived from the amplitude and phase difference between the I- and Q-mixers [16, pp. 72–73]. The power amplifier stage can be modelled as a non-linear system with memory using the Volterra series [17, 18]. However, for wireless systems where (typically) the signal bandwidth is small compared to the carrier frequency, the Volterra series can be simplified to a memory polynomial expansion [17, 19]. In this case, for an arbitrary non-linearity excited with input $x(n)$, the output signal $y(n)$ can be expressed by

$$y(n) = \sum_{k \in \mathcal{K}} \sum_{m \in \mathcal{M}} a_{km} x_{\text{IQ}}(n-m) \left| x_{\text{IQ}}(n-m) \right|^{k-1}, \quad (3)$$

where a_{km} are the power amplifier coefficients, and \mathcal{K} and \mathcal{M} are the sets of polynomial orders and delays, respectively [17]. For a typical RF power amplifier only odd ordered polynomial terms are included, as even ordered harmonics of the RF signal would fall out of band. The basis functions in (3) have the form $x(n) |x(n)|^{k-1}$ to ensure the phase information in $x(n)$ is preserved.

2.2. Predistortion for All Hardware Impairments

The basic idea behind predistortion is to distort the transmit signal in the digital baseband to compensate for the non-linear distortion and memory effects introduced by the baseband and passband hardware impairments. In the ideal case, when a baseband predistorted signal is applied to the non-linear hardware, the passband output will be free from non-linear distortion. Accordingly, for a full-duplex transceiver, predistortion

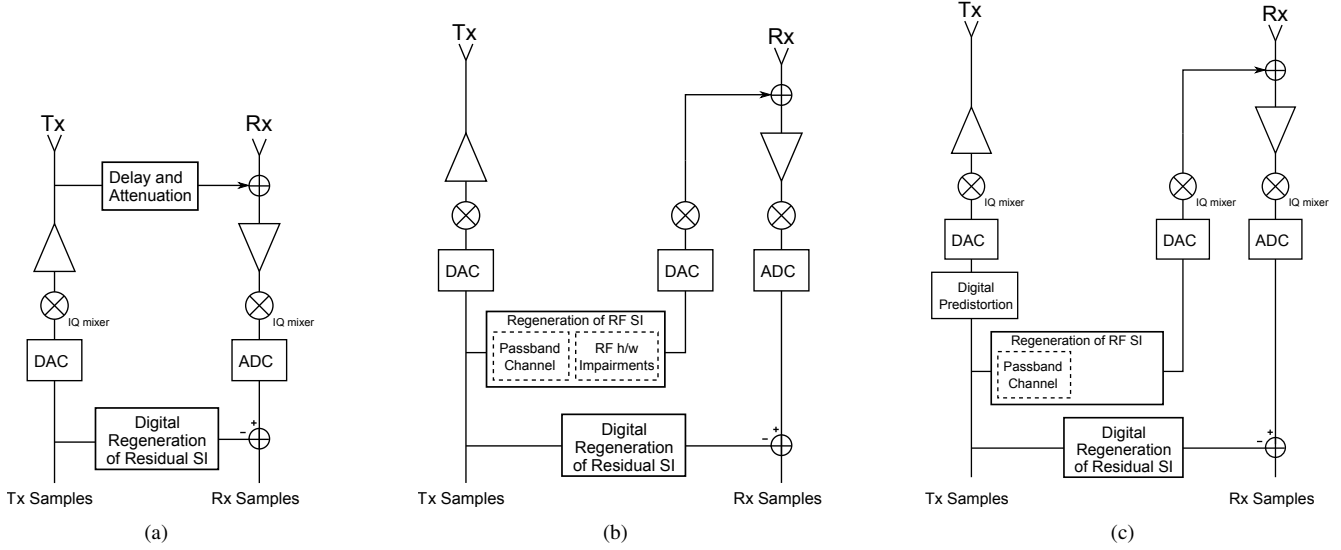

Fig. 1. Full duplex system architectures: (a) RF cancellation circuit; (b) regeneration from the digital baseband; and (c) proposed regeneration with digital predistortion for hardware impairments.

of the transmitted signal would thus considerably simplify the design and implementation of the cancellation algorithms at both the RF and digital stages, as shown in Fig. 1(c).

Predistorting for the hardware impairments requires the inversion of (3). Unfortunately, explicitly inverting (3) is complicated. However, following the approach of [17] and [18] for signals where the bandwidth is small compared the carrier frequency, we can use (3) to model the inverse of the non-linear system directly, i.e., the output is used to predict the input. This method is termed postdistortion. The post-distortion coefficients in (3) are estimated by sending a training frame and applying least-squares estimation to the training and the received signal [17]. Following convergence, these coefficients are copied into the predistortion stage and the system is run in open-loop configuration [17].

Cascading the hardware impairment models for the DAC non-linearities, IQ imbalance, and the power amplifier non-linearities (with memory effects) leads to a transmit signal

$$y(n) = \sum_{k \in K} \sum_{m \in M} a_{km} [\alpha x_{\text{DAC}}(n-m) + \beta x_{\text{DAC}}^*(n-m)] \cdot \left| \alpha x_{\text{DAC}}(n-m) + \beta x_{\text{DAC}}^*(n-m) \right|^{k-1}, \quad (4)$$

where $x_{\text{DAC}}(n)$ includes the DAC non-linearities given by (1). It is difficult to directly estimate the coefficients in (4) using least-squares estimation. However, (4) can be expanded and expressed with a different basis, in which the real and imaginary parts of the signal are separated, e.g.,

$$y(n) = \sum_{g \in \mathcal{G}} \sum_{f \in \mathcal{F}} \sum_{h \in \mathcal{H}} \sum_{l \in \mathcal{L}} b_{gfhl} \Re(x(n-h))^f \Im(x(n-l))^g, \quad (5)$$

where b_{gfhl} are the coefficients, and \mathcal{F} and \mathcal{G} are the set of polynomial orders for the real and imaginary parts, and \mathcal{H} and \mathcal{L} are the corresponding sets of delay terms respectively. In this form, the required set of post-distortion coefficients, b_{gfhl} , can be computed in a straightforward manner using least-squares estimation.

3. EXPERIMENTAL VALIDATION

Our hardware testbed is based on the National Instruments PXI platform with two NI-5791 RF transceiver modules operating in the 2.4 GHz ISM band [6, 7]. Baseband signal processing is performed in Matlab, and the NI-5791 modules are configured using Labview. An external 30 dB gain amplifier (Skyworks SE2576L) is used to increase the average transmitted power to approximately 10 dBm. The transmit and receive antennas are ‘rubber-duck’ monopoles, and are placed 25 cm apart with the same polarisation, resulting in 25 dB of passive suppression. As shown in Fig. 1(b) and (c), the cancellation signal is ‘added’ to the received signal from the antennas before the receiver chain using an RF combiner. The transmitted signal used to estimate the predistortion coefficients consists of a frame containing 20 2048-tone OFDM symbols, where each sub-carrier is modulated with 64-QAM representing a random bit-stream. Frame synchronisation symbols or pilot tones are not included. The OFDM signal has a bandwidth of 20 MHz (the signals are sampled at 60 MHz to capture the out-of-band emissions). The carrier frequency was 2.48 GHz, and the local oscillator was shared between the transmit, receive, and cancellation chains to reduce the impact of phase-noise.

Fig. 2(a) shows an experimental measurement of the power spectral density recorded on the full-duplex testbed

when no digital predistortion is applied, i.e., using the architecture depicted in Fig. 1(b). In this case the analog cancellation signal only contains linear time-delayed components. Significant out-of-band emissions are observed in the transmitted signal, and these remain in the residual self-interference after both the analog and digital suppression stages. In particular, the residual after analog suppression is approximately 23 dB above the measured noise-floor. The digital suppression stage (using the model outlined in [6], which only accounts for a limited number of coupled IQ and non-linear terms) only improves the suppression by an additional 2 dB. The noise-floor is measured when ‘transmitting’ an empty, i.e., all zero, frame and thus includes also the thermal noise arising from the cancellation chain. The increase in the residual observed beyond ± 27 MHz arises from LO leakage in the cancellation chain.

Fig. 2(b) shows the power spectral density when predistorting only for the power amplifier non-linearities using (3), with the architecture depicted in Fig. 1(c). A comparison with Fig. 2(a) shows the out-of-band emissions in the analog residual component (and the transmitted signal) are significantly reduced. Unfortunately, the analog residual is still approximately 21 dB above the noise-floor. However, the digital suppression stage, with the same model applied in Fig. 2(a), can further reduce the self-interference by approximately 12 dB.

While predistortion for the power amplifier improves the overall suppression, this is only achieved in the digital stage. The high analog residual measured in Fig. 2(b) therefore reduces the receiver sensitivity. In contrast, as shown in Fig. 2(c) predistortion for all significant hardware impairments, using (5), improves the performance of the analog suppression stage by 10 dB, compared to only predistorting for the power amplifier. The analog residual is thus only approximately 10 dB above the measured noise-floor, and importantly, this suppression is achieved in the analog domain, *before* the signal reaches the receiver. In this case the digital suppression stage does not further reduce the self-interference.

4. CONCLUSIONS

Regeneration-based full-duplex transceivers are prone to the effects of hardware impairments, which introduce significant non-linear components in the self-interference signal, particularly at high transmit power. Digital predistortion for hardware impairments in the transceiver chain—e.g., mixer IQ-imbalance, DAC non-linearities, and power amplifier non-linear memory effects—effectively ‘linearises’ the self-interference signal and allows for increased suppression. Results on a hardware testbed operating at 2.48 GHz shows that predistortion for all significant hardware impairments in a full-duplex transceiver can increase the analog suppression by an additional 14 dB for a 20 MHz OFDM signal, compared to a conventional regeneration architecture with no predistortion.

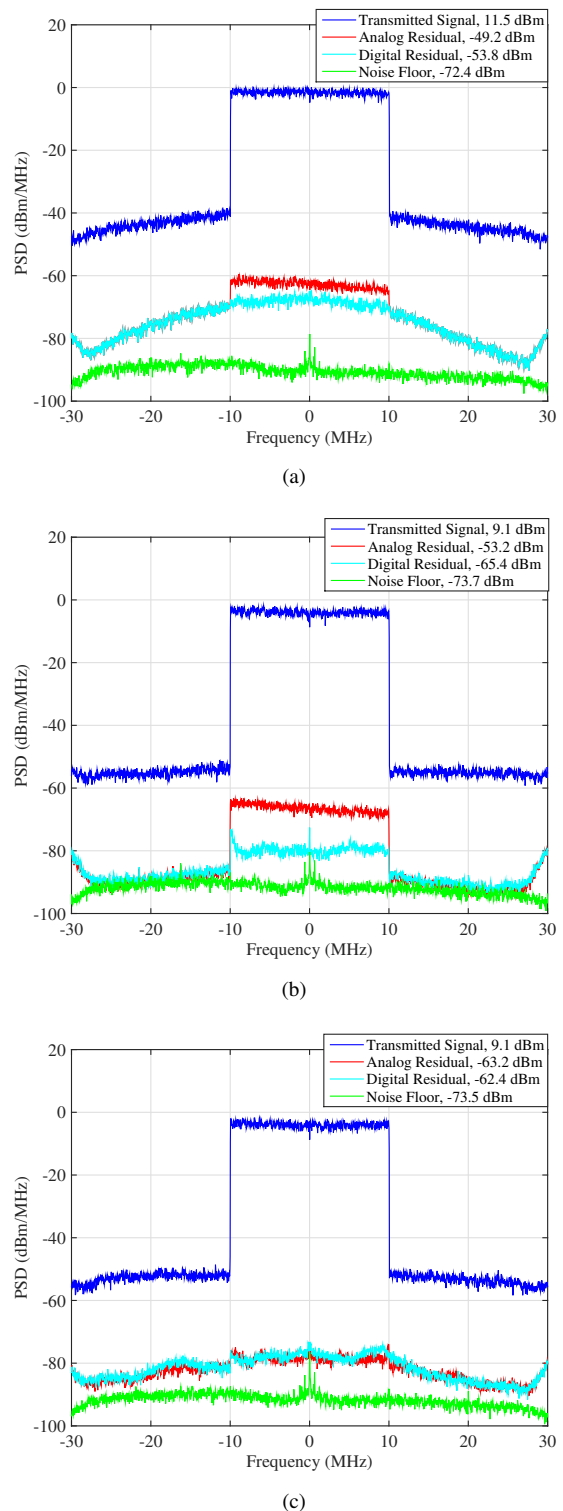

Fig. 2. Experimentally measured self-interference power spectral density with: (a) no digital predistortion; (b) predistortion only for the power amplifier; and (c) predistortion of all significant hardware impairments.

5. REFERENCES

- [1] M. Jain, J.-I. Choi, T. Kim, D. Bharadia, S. Seth, K. Srinivasan, P. Levis, S. Katti, and P. Sinha, "Practical, real-time, full duplex wireless," in *Proc. 17th International Conference on Mobile Computing and Networking*. ACM, 2011, pp. 301–312.
- [2] M. Duarte, C. Dick, and A. Sabharwal, "Experiment-driven characterization of full-duplex wireless systems," *IEEE Trans. Wireless Commun.*, vol. 11, no. 12, pp. 4296–4307, 2012.
- [3] T. Riihonen and R. Wichman, "Analog and digital self-interference cancellation in full-duplex MIMO-OFDM transceivers with limited resolution in A/D conversion," in *Asilomar Conference on Signals, Systems and Computers*, 2012, pp. 45–49.
- [4] A. Sabharwal, P. Schniter, Dongning Guo, D.W. Bliss, S. Rangarajan, and R. Wichman, "In-band full-duplex wireless: Challenges and opportunities," *IEEE J. Sel. Areas Commun.*, vol. 32, no. 9, pp. 1637–1652, 2014.
- [5] Yang-Seok Choi and Hooman Shirani-Mehr, "Simultaneous transmission and reception: Algorithm, design and system level performance," *IEEE Trans. Wireless Commun.*, vol. 12, no. 12, pp. 5992–6010, 2013.
- [6] A. Balatsoukas-Stimming, A.C.M. Austin, P. Belanovic, and A. Burg, "Baseband and RF hardware impairments in full-duplex wireless systems: experimental characterisation and suppression," *EURASIP Journal on Wireless Communications and Networking*, vol. 2015, no. 142, 2015.
- [7] A.C.M. Austin, A. Balatsoukas-Stimming, and A. Burg, "Digital predistortion of power amplifier non-linearities for full-duplex transceivers," in *IEEE International workshop on Signal Processing Advances in Wireless Communications*, July 2016.
- [8] S. Ramakrishnan, L. Calderin, A. Niknejad, and B. Nikolic, "An FD/FDD transceiver with RX band thermal, quantization, and phase noise rejection and >64dB TX signal cancellation," in *IEEE Radio Frequency Integrated Circuits Symposium*, 2017, pp. 352–355.
- [9] A. Balatsoukas-Stimming, P. Belanovic, K. Alexandris, and A. Burg, "On self-interference suppression methods for low-complexity full-duplex MIMO," in *Asilomar Conference on Signals, Systems and Computers*, 2013, pp. 992–997.
- [10] D. Korpi, L. Anttila, V. Syrjala, and M. Valkama, "Widely linear digital self-interference cancellation in direct-conversion full-duplex transceiver," *IEEE J. Sel. Areas Commun.*, vol. 32, no. 9, pp. 1674–1687, Sept 2014.
- [11] V. Syrjala and K. Yamamoto, "Is sampling jitter a problem in full-duplex radio transceivers or not?," in *IEEE 79th Vehicular Technology Conference (VTC Spring)*, 2014, pp. 1–5.
- [12] A. Sahai, G. Patel, C. Dick, and A. Sabharwal, "On the impact of phase noise on active cancelation in wireless full-duplex," *IEEE Trans. Veh. Technol.*, vol. 62, no. 9, pp. 4494–4510, Nov 2013.
- [13] V. Syrjala, M. Valkama, L. Anttila, T. Riihonen, and D. Korpi, "Analysis of oscillator phase-noise effects on self-interference cancellation in full-duplex OFDM radio transceivers," *IEEE Trans. Wireless Commun.*, vol. 13, no. 6, pp. 2977–2990, June 2014.
- [14] L. Anttila, D. Korpi, E. Antonio-Rodriguez, R. Wichman, and M. Valkama, "Modeling and efficient cancellation of nonlinear self-interference in MIMO full-duplex transceivers," in *Globecom Workshops*, 2014, pp. 777–783.
- [15] Shenghong Li and R.D. Murch, "An investigation into baseband techniques for single-channel full-duplex wireless communication systems," *IEEE Trans. Wireless Commun.*, vol. 13, no. 9, pp. 4794–4806, 2014.
- [16] L. Smaïni, *RF Analog Impairments Modeling for Communication Systems Simulation: Application to OFDM-based Transceivers*, Wiley, Chichester, 2012.
- [17] D.R. Morgan, M. Zhengxiang, Kim Jaehyeong, M. G. Zierdt, and J. Pastalan, "A generalized memory polynomial model for digital predistortion of RF power amplifiers," *IEEE Trans. Signal Process.*, vol. 54, no. 10, pp. 3852–3860, Oct. 2006.
- [18] C. Eun and E.J. Powers, "A new Volterra predistorter based on the indirect learning architecture," *IEEE Trans. Signal Process.*, vol. 45, no. 1, pp. 223–227, Jan. 1997.
- [19] J. Kim and K. Konstantinou, "Digital predistortion of wideband signals based on power amplifier model with memory," *Electron. Lett.*, vol. 37, no. 23, pp. 1417–1418, Nov. 2001.