



<http://researchspace.auckland.ac.nz>

ResearchSpace@Auckland

Copyright Statement

The digital copy of this thesis is protected by the Copyright Act 1994 (New Zealand).

This thesis may be consulted by you, provided you comply with the provisions of the Act and the following conditions of use:

- Any use you make of these documents or images must be for research or private study purposes only, and you may not make them available to any other person.
- Authors control the copyright of their thesis. You will recognise the author's right to be identified as the author of this thesis, and due acknowledgement will be made to the author where appropriate.
- You will obtain the author's permission before publishing any material from their thesis.

To request permissions please use the Feedback form on our webpage.

<http://researchspace.auckland.ac.nz/feedback>

General copyright and disclaimer

In addition to the above conditions, authors give their consent for the digital copy of their work to be used subject to the conditions specified on the Library Thesis Consent Form.

**STUDIES OF MALNUTRITION IN PATIENTS
WITH INFLAMMATORY BOWEL DISEASE**

PETER MICHAEL CHRISTIE

MD THESIS MAY 1990

**Department of Surgery
University of Auckland
New Zealand**

ABSTRACT

Patients suffering from Inflammatory Bowel Disease (IBD) as a group uniformly suffer from nutritional problems. Nevertheless the extent, severity and clinical significance of Protein Energy Malnutrition (PEM) in the various clinical presentations of these diseases remains unclear. In particular little is known of the nutritional status of the ambulatory patient with IBD. Confusion still exists over the long term nutritional changes following colectomy for colitis. Whether intravenous nutrition (IVN) should be prescribed in patients admitted to hospital for acute exacerbations of IBD still remains contentious.

Recent work suggests that the significance of PEM relates to the associated impairments seen in various organ systems eg., impaired respiratory muscle function. Furthermore, there is other data to suggest that nutritional therapy may result in improvement in some of these physiological functions long before there is any measured change in the patient's nutritional status.

Through direct measurements of Body Composition (by neutron activation analysis in conjunction with tritium dilution) together with tests of physiological function (hepatosecretory proteins, skeletal muscle function, respiratory muscle function, wound healing and psychological function) work has been directed to clarify the following clinical questions:-

1. How extensive is the problem of protein depletion in the various clinical presentations of IBD?
2. What are the long term changes in body composition following

surgery for colitis? and what is the nature of this restorative process. Is there a return to normal body composition? and if so, what is the duration of this recovery process?

3. What are the effects of a short course of IVN in patients suffering severe exacerbations

of IBD?

The results of these clinical studies have reaffirmed the high incidence of PEM in patients suffering from acute exacerbations of IBD, furthermore this work has established the existence of persisting protein deficits in the ambulatory patient with IBD who is in clinical remission. Contrary to previous reports, fully convalescent patients following surgery for colitis, were found to have normal body stores of protein and water. The timing of this restorative process was found however to take many months.

A 2 week course of IVN was found not only to prevent further loss of body protein in a group of patients presenting with severe exacerbations of IBD, but also within a few days (4 days) lead to a significant improvement in hepatosecretory function, respiratory muscle function, skeletal muscle function, wound healing and psychological function. The magnitudes of these improvements although not complete was probably significant clinically. Following these early improvements, subsequent improvement was slow over many months and was dependent on an increase in body stores of protein.

TABLE OF CONTENTS

	PAGE
List of Colour Plates	vii
Acknowledgements	viii
Preface	ix
List of Abbreviations	xiii
<u>SECTION 1</u>	<u>INTRODUCTION AND LITERATURE</u>
	<u>REVIEW</u>
	1
CHAPTER 1	THE PROBLEM OF SURGICAL
	MALNUTRITION
	1
part i	Introduction
	2
part ii	Problems of Classification
	4
part iii	Body Composition in Health and
	Disease
	7
part iv	The Effects of Malnutrition -
	Abnormalities of Organ Function
	12
part v	The High Risk Surgical Patient -
	A Problem of Identification
	15
part vi	The Effect of Nutritional
	Repletion
	16
CHAPTER 2	THE PATIENT WITH INFLAMMATORY
	BOWEL DISEASE
	18
part i	Background
	18
part ii	Mechanisms of Malnutrition in
	Patients with Inflammatory Bowel
	Disease
	22
part iii	Prevalence of Nutritional
	Deficiencies in Inflammatory Bowel
	Disease
	24
part iv	Management of Patients with
	Inflammatory Bowel Disease
	29
CHAPTER 3	SUMMARY AND AIMS OF THESIS
	39
<u>SECTION 2</u>	<u>METHODS</u>
	41
CHAPTER 4	EVALUATION OF WEIGHT LOSS
	42
CHAPTER 5	ASSESSMENT OF BODY COMPOSITION
	44
part i	Total Body Protein
	44
part ii	Total Body Water
	45
part iii	Total Body Minerals
	47
part iv	Fat Free Body Mass
	47
part v	Total Body Fat
	47
part vi	Assessment of Protein Depletion
	52
part vii	Assessment of Fat Depletion
	53
part viii	Radiation Dose
	53
part ix	Hydration of the Fat Free Body

	Mass	53
part x	Measurement of Extracellular Water Volume	54
part xi	Total Body Potassium	55
part xii	Muscle Protein	56
CHAPTER 6	MEASUREMENT OF RESTING ENERGY EXPENDITURE	62
part i	Description of the Indirect Calorimeter Apparatus	63
part ii	Standard Technique	65
part iii	Assumptions and Errors	68
CHAPTER 7	PLASMA PROTEINS	73
part i	Transferrin	73
part ii	Prealbumin	74
CHAPTER 8	URINE AND ILEOSTOMY CHEMISTRY	76
CHAPTER 9	WOUND HEALING RESPONSE	83
CHAPTER 10	SKELETAL MUSCLE FUNCTION	86
part i	Maximal Voluntary Grip Strength	86
part ii	Involuntary Skeletal Muscle Function	89
CHAPTER 11	RESPIRATORY MUSCLE FUNCTION	94
part i	Respiratory Muscle Strength	94
part ii	Maximal Voluntary Ventilation	97
part iii	Spirometric Tests	99
CHAPTER 12	PSYCHOLOGICAL FUNCTION	102
CHAPTER 13	INTRAVENOUS NUTRITION	111
CHAPTER 14	EXPERIMENTAL PROTOCOL	116
CHAPTER 15	STATISTICAL ANALYSIS	117
<u>SECTION 3</u>	<u>THE PROBLEM OF PROTEIN ENERGY MALNUTRITION</u>	119
CHAPTER 16	CHANGES IN THE BODY STORES OF PROTEIN, FAT AND WATER IN IBD A BODY COMPOSITIONAL SURVEY	120
<u>SECTION 4</u>	<u>THE LONG TERM CHANGES AFTER SURGERY FOR ULCERATIVE COLITIS</u>	147
CHAPTER 17	THE LONGITUDINAL CHANGES IN PROTEIN, FAT AND WATER FOLLOWING J-POUCH FOR ULCERATIVE COLITIS	148

CHAPTER 18	METABOLISM OF BODY WATER AND ELECTROLYTES AFTER SURGERY FOR ULCERATIVE COLITIS - ILEOSTOMY VERSUS J-POUCH	166
CHAPTER 19	RISK OF URINARY STONE FORMATION FOLLOWING SURGERY FOR ULCERATIVE COLITIS - ILEOSTOMY VERSUS J-POUCH	185
<u>SECTION 5</u>	<u>THE EFFECTS OF NUTRITIONAL REPLETION</u>	201
CHAPTER 20	INTRODUCTION, METHODS AND STUDY DESIGN	202
CHAPTER 21	CHANGES IN SKELETAL MUSCLE FUNCTION	216
CHAPTER 22	CHANGES IN RESPIRATORY MUSCLE FUNCTION	229
CHAPTER 23	CHANGES IN THE WOUND HEALING RESPONSE	246
CHAPTER 24	CHANGES IN PSYCHOLOGICAL FUNCTION	252
<u>SECTION 6</u>	<u>SUMMARY AND CONCLUSION</u>	264
CHAPTER 25	SUMMARY AND CONCLUSIONS	
	REFERENCES	i-xxi

LIST OF COLOUR PLATES

IVNAA FACILITY, DEPARTMENT OF SURGERY, UNIVERSITY OF AUCKLAND	61
SHADOW SHIELD, WHOLE BODY POTASSIUM COUNTER, DEPARTMENT OF SURGERY, UNIVERSITY OF AUCKLAND	61
A PATIENT HAVING MAXIMAL VOLUNTARY GRIP STRENGTH MEASURED	92
A PATIENT HAVING INVOLUNTARY SKELETAL MUSCLE FUNCTION ASSESSED	93
A PATIENT UNDERGOING RESPIRATORY MUSCLE FUNCTION ASSESSMENT	101

ACKNOWLEDGEMENTS

I would like to acknowledge Professor Graham Hill who provided me with the opportunity to conduct this clinical research. In addition he provided strong guidance, encouragement, support, discipline and above all, a critical analysis of my data.

I would like to also acknowledge my wife, Nichola for support, helpful editing and accepting my persistent absence during the time of preparation of this thesis.

Most importantly I am indebted to all the young brave patients of Professor Hill who generously gave their time, effort and encouragement often during periods of pain and worry. It is my hope that through their help and effort some aspects of this work may lead to a greater understanding of their difficult nutritional problems.

PREFACE

The clinical studies reported in this thesis were performed over the two year period (1986-1988) during which time I held the position of Temporary Lecturer in Surgery, University of Auckland.

During this time I was actively involved in the clinical assessment and management of patients with complex fluid, electrolyte, and nutritional problems, many of whom were suffering from acute exacerbations of IBD.

It was through this early clinical experience that I became interested in examining the problem of Protein Energy Malnutrition in this clinical group of patients and examining the efficacy of IVN.

All studies included in this thesis had ethical approval by the Auckland Hospital Ethical Committee and all raw data may be found at the end of each respective chapter.

Subsequently and over the period of this clinical research, the clinical studies described in this thesis have culminated in the following publications and presentations;

PUBLICATIONS

1. Christie P.M. Hill G.L.
Early improvement in skeletal muscle function following a short course of intravenous nutrition.
Aust NZJ Surg 58: 230-231 1988 (Abstract)

2. Christie P.M. Hill G.L.
Restoration of normal body composition in the months following J-pouch for ulcerative colitis
Aust NZJ Surg 59: 268, 1989 (abstract)

3. Christie P.M. Hill G.L.
Metabolism of body water and electrolytes after surgery for ulcerative colitis - Brooke ileostomy versus J-pouch
Aust NZJ Surg. 59: 268 (abstract)

4. Christie P.M. Schroeder D. Hill G.L.
Persisting superior, mesenteric artery syndrome following ileoanal J-pouch anastomosis
Br. J. Surg. 1988; Vol 75: Oct 1036

5. Schroeder D. Christie P.M. Hill G.L.
Bioelectrical impedance analysis for body composition ; clinical evaluation in general surgical patients
JPEN (in press)

6. Christie P.M. Knight G.S. Hill G.L.
Metabolism of body water and electrolytes after surgery
for ulcerative colitis - Brooke ileostomy versus J-pouch
Br. J. Surg. 1990: 77; 149-151

7. Christie P.M. Hill G.L.
Improved respiratory muscle function following a short
course of Intravenous Nutrition
Br. J. Surg. (in press)

8. Hill G.L. Witney G.B. Christie P.M. Church J.M.
Nutritional Syndromes and the effect of Intravenous
Nutrition (IVN) on Protein Nutriture - A prospective
study of surgical patients with gastrointestinal disease
Lancet (in press)

9. Christie P.M. Knight G.S. Hill G.L.
Risk of Urinary stone formation following surgery for
ulcerative colitis ileostomy versus J-pouch
Br. J. Surg. (Submitted)

10. Christie P.M. Hill G.L.
Return to normal body composition after ileo-anal J-pouch
for ulcerative colitis
Diseases of Colon and Rectum (in press)

11. Christie P.M. Hill G.L.

Effect of intravenous nutrition on nutrition and function
in acute attacks of inflammatory bowel disease.

Gastroenterology (in press).

PRESENTATIONS

1. Surgical Research Society of Australasia annual meeting
1987 (Dunedin NZ): Early Improvement in Skeletal Muscle
Function following a short course of Intravenous Nutrition.
2. RACS Scientific Meeting 1988 (Palmerston North NZ)
Metabolism of Body Water and Electrolytes after surgery
for ulcerative colitis - Brooke Ileostomy versus J-pouch
3. Surgical Research Society of Australasia 1988 (Sydney,
Australia): Restoration of normal body composition in the
months following J-pouch for ulcerative colitis
4. Surgical Research Society of Australasia 1988 (Sydney,
Australia): Metabolism of body water and electrolytes
after surgery for ulcerative colitis - Brook Ileostomy
versus J-pouch.
5. Surgical Research Society of England, 1989 (Newcastle,UK)
Improved Respiratory Muscle Function following a short
course of intravenous nutrition.

LIST OF ABBREVIATIONS

BMM	Bone Mineral Mass
BCM	Body Cell Mass
CDAI	Crohn's Disease Activity Index
Ci	Curie per litre
CT	Computerised Tomography
ECW	Extracellular Water
EN	Enteral Nutrition
FEV1	Forced Expiratory Volume in 1 second
FFM	Fat Free Body Mass
Fig.,	Figure
GAGS	Glycosamino Glycan Inhibitors
GI	Grip Strength Index
GS	Grip Strength
GSI	Global Severity Index
IBD	Inflammatory Bowel Disease
IVN	Intravenous Nutrition
IVNAA	In Vivo Neutron Activation Analysis
J-P	J-pouch
K	Potassium
MEP	Maximal Static Expiratory Pressure
MEV	Milli Electron Volt
MIP	Maximal Static Inspiratory Pressure
MMV	Maximal Minute Ventilation
MSV	Maximal Sustainable Ventilation
MVV	Maximal Voluntary Ventilation

N	Nitrogen
NaBr	Sodium Bromide
Na I	Sodium Iodide
PEFR	Peaked Expiratory Flow Rate
PEM	Protein Energy Malnutrition
POMS	Profile of Mood States
PPN	Partial Parenteral Nutrition
PSDI	Positive Symptom Distress Index
PST	Positive Symptom Total
Pu-Be	Plutonium-Beryllium
REE	Resting Energy Expenditure
RME	Resting Metabolic Expenditure
RQ	Respiratory Quotion
SCL	Symptom Check List
SD	Standard Deviation
SEE	Standard Error of the Estimate
SEM	Standard Error of the Mean
TBF	Total Body Fat
TBK	Total Body Potassium
TBM	Total Body Minerals
TBN	Total Body Nitrogen
TBP	Total Body Protein
TBW	Total Body Water
THO	Tritiated Water
TOBEC	Total Body Electrical Conductivity
VC	Vital Capacity
X	Mean

SECTION 1 : INTRODUCTION AND LITERATURE REVIEW

CHAPTER 1 : THE PROBLEM OF SURGICAL MALNUTRITION

Part i. **Introduction**

"With the pleasure of eating is joined hunger, and that after no very equal sort. For these two, the grief is both the more vehement and also of longer continuance. For it riseth before the pleasure, and endeth not until the pleasure die with it."

SIR THOMAS MOORE, UTOPIA, The Second Book "Of Their Journeying or Travelling Abroad, with Divers Other Matters."

Starvation and weight loss are universal accompaniments of surgical illness. Anorexia, fear and starvation necessitated by investigation or the operative procedure can only act to compound this problem. This weight loss is too often associated with abnormalities of physiological function. An appreciation of this association was clearly seen in 1950, with the Minnesota experiment (Keys et al 1950).

The clinical significance of surgical weight loss had been also previously clearly demonstrated more than 50 years ago when a Cleveland surgeon Hiram Studley (Studley 1936), carefully controlling for the age of the patient; the operating surgeon and the type and length of the procedure, found a striking correlation between the magnitude of pre-operative weight loss and

post-operative mortality.

Part ii : Problems of Classification

For the adult surgical patient suffering from malnutrition there are major problems of classification. Early investigators examining malnutrition in hospitalised adult patients for the first time, attempted to apply a pre-existing system of assessment, based on childhood Protein Energy Malnutrition (PEM). Unfortunately the differences between these two clinical situations were not appreciated. For instance, weight per height, and anthropometry had only a crude relationship to protein energy status in the adult (Frisancho, 1984). In striking contrast, diminished velocity of growth in the child was one of the very earliest and most sensitive indicators of developing PEM (McLaren et al, 1972). Furthermore the clinical spectrum of these two illnesses was quite different.

For instance, Kwashiorkor was almost unknown in adult patients with PEM. The vast majority of PEM in adult surgical patients being the Marasmic form.

Investigators who had categorised malnourished patients in hospitals, treated PEM as if it were a single simple diagnosis. As a consequence of this difficulty they have been satisfied to employ as indicators of PEM, tests that are inappropriate for the Marasmic form eg., the use of depression of levels of serum proteins, i.e. albumin, transferrin, pre-albumin, retinol-binding protein. Such tests were not affected by chronic starvation, but

rather were more often more affected by co-existing diseases eg., liver disease or infection rather than nutritional status.

Similar criticism can be made of the other prognostic indices that have been developed (Buzby et al 1980, Lowe et al 1983, Harvey et al 1981). The Prognostic Nutritional Index of Mullen and Co-workers (Buzby et al 1980) has been widely applied. Although it has been shown to be highly predictive of outcome in surgical patients, it is not a nutritional index. It is interesting that Harvey et al, 1981 chose not to relate their index to nutritional status but called it a "Hospital Prognostic Index".

Blackburn and Bistran made no attempt to distinguish between different forms of PEM which they termed Marasmic and adult Kwashiorkor - like syndrome (Bistran 1977). In recent years they have used the term "hypoalbuminaemic malnutrition (Bistran et al 1975) which seems more appropriate than to liken this condition to Kwashiorkor, as all other clinical features of this disease are absent.

Bistran and Blackburn pointed out that the Marasmic form in adults is generally well tolerated and is not in itself life threatening (Bistran et al 1975). This is not the case in children. Adult Marasmus does however progress rapidly to hypoalbuminaemic malnutrition when the catabolic stress from injury or infection supervenes. These patients have a much greater risk of being anergic, becoming septic and of failing to survive. (Harvey et al 1978; Harvey et al 1979).

It is clear from this discussion that there are problems

classifying the adult surgical patient with malnutrition. They represent a heterogenous group with different prognoses and different responses to nutritional therapy. A clearer distinction of these nutritional syndromes must therefore be an urgent task.

Part iii : Body Composition in Health and Disease

In the words of Francis Moore, " the study of body composition is the study of the gross chemical anatomy of the living body." (Moore et al 1963).

The Body Cell Mass as defined by Francis Moore (Moore et al 1963) is the homogeneous energy exchanging work performing moiety of body tissue.

At the present time until we have a direct measurement of intracellular protein, the Body Cell Mass (BCM) remains the fundamental metabolic unit. It comprises approximately 30-45% of the body weight and includes the skeletal muscle and visceral parenchyma.

These two components of the BCM have different implications for body function and composition.

The skeletal muscle mass can rest between exertions, varies widely in disease or disuse and is essential only for the mobility of the skeleton. By contrast the visceral parenchyma must function for the most part each day, oxidizing substrates, exchanging energy and using oxygen while the body as a whole is resting. These visceral components of the BCM do not decrease in size during wasting diseases.

The basic metabolic rate or basal metabolic expenditure at rest measures the energy turnover largely of the visceral components of the body cell mass, because the muscular components are now at rest and are burning very little fuel.

The Extracellular Supporting Tissue

Surrounding and supporting the BCM is a heterogeneous group of structures, tissues and fluids identified as extracellular tissues. These consist of fluid components on the one hand and solids on the other. The fluid components comprise the extracellular fluid with its division into the plasma, the lymph, the interstitial fluid and the transcellular fluids. The extracellular solids include tendon, dermis, collagen, elastin, fascia and most significant by weight, the skeleton. The liquid - solid partition of the extracellular tissue is subject to wide fluctuations in disease because of the accumulations of extracellular water which is sodium-rich and potassium poor.

Hydration of the Fat Free Body

As body fat is chiefly anhydrous and varies widely in individuals it is important to index changes in total body water to the weight of lean tissue present i.e., the Fat Free Body Mass (FFM). The FFM is equivalent to body weight minus Total Body Fat (TBF).

In disease states the average hydration of the FFM can vary (usually upwards) but only within certain well defined limits. These limits have been defined according to the extreme conditions; wasting by loss of cells alone, or the accumulation of extracellular fluid.

According to Moore and Boyden (1963) nearly all disease results in an increased hydration of the body. In the situation of pathological water accumulation the co-efficient rises to near 0.85. In other work Dr Moore suggests that the clinical

implication of this is that wasted patients with high hydration ratios are intolerant of salt and water, and hence have a tendency towards oedema, hypoproteinaemia and hypotonicity (Moore 1959). However recent work (Beddoe et al 1985) suggests that some starving patients do not have this problem and when salt and water restriction is applied too vigorously to this group, hypovolaemia may become apparent.

Body Fat

The body fat component is considered as an anhydrous accumulation of neutral triglycerides. Of all the components of body composition the total mass of body fat is the most variable. Very obese females may have 50% of their body weight as fat, whereas very well trained muscular athletes will show fat contents around 10% of body weight.

The Skeleton

This component of the extracellular tissue is dry, heavy, dense, fat free and potassium free. It is thus a component of extracellular solids that contain a large weight of fat free solids, but only a small amount of potassium.

Body Composition in Wasting Disease, Anabolic Recovery, Dietary Weight Loss, Corticosteroid therapy and Major Surgical Stress

The characteristic compositional change of wasting disease is a loss of fat, fat free mass and an increasing hydration. The skeletal muscle mass bears the brunt of this cellular wasting.

Visceral components of the BCM are relatively spared.

The extracellular phase tends to be maintained as wasting proceeds. As Dr Moore describes (Moore et al 1963) , the clinical appearance of these patients is one of "skin, bones, tendon, fascia and plasma volume cachexia."

The Phenomenon of Anabolism

Anabolic recovery from wasting is commonly seen in the recovery phase of any wasting disease eg., acute exacerbations of Inflammatory Bowel Disease (IBD).

Weight is gained through resynthesis of muscle tissue and later there is restoration of body fat stores.

Characteristically there is less water gained than weight with a gradual restoration of the BCM, associated with a gradual diuresis of extracellular water and salt.

Corticosteroid Therapy

Corticosteroids are potent at producing a selective loss of the BCM with preservation of fat stores. The extracellular water space is also increased.

Sepsis

The patient with an exacerbation of IBD is very typical of the stressed surgical patient. The characteristic compositional change is a loss of cellular mass indicative of cellular catabolism, accompanied by an obligatory sequestered accumulation of extracellular fluid. This cellular catabolism is among the most

rapid seen in man and has been appropriately termed by Dr Moore as "Septic post- traumatic catabolism"(Moore et al 1963). It is not surprising therefore that these patients are critically ill.

It is clear from this brief introduction to body composition that a surgical patient subjected to surgical stress, starvation, inflammatory or malignant disease complicated further by possible infection can only respond compositionally in a very uniform way - so beautifully described by Frances Moore - "a loss of lean tissue, chiefly cellular protein (mainly skeletal muscle) slight relative preservation of fat stores and a uniform tendency for an increasing hydration of body tissues (extracellular)".

During recovery from illness, through the process of anabolism, these body compositional changes will be restored towards normality.

In this thesis I will endeavour to examine and to characterise my patients with IBD in terms of some of these body compositional changes. Where possible, I will relate these changes to the clinical state or presentation of their illness, the presence of a surgical complication. I will attempt to relate body composition to organ physiological function.

Finally the body compositional changes in recovery will be examined.

Part iv : The Effects of Surgical Malnutrition - Abnormalities of Organ Function.

The compositional and metabolic changes of malnutrition mentioned in the previous section of this chapter do not occur in isolation but rather may be associated with abnormalities in many organ systems. It is the presence of these abnormalities that culminate in these patients having a high risk of post-operative complications (Studley 1936; Buzby et al 1980; Mullen et al 1980; Windsor et al 1988).

Psychology

The intellect remains clear but there is a personality change with inability to concentrate, irritability and apathy (Keys et al 1950).

Skeletal Muscle

Along with wasting of skeletal muscle, and muscle weakness there is a selective atrophy of the Type II muscle fibres with a consequent increase in muscle fatiguability (Church et al 1984; Russell et al 1983).

Respiratory Function

Malnourished patients have a reduced capacity to sustain adequate levels of ventilation from the effects both on the central nervous system and respiratory muscle. Neural ventilatory drive is impaired and inspiratory and expiratory muscle weakness is

demonstrable (Rochester et al 1984; Lopes et al 1982). Furthermore these patients have a significantly increased risk for developing post-operative pneumonia(Windsor et al 1988c)

Cardiovascular System

Malnourished patients have been found to have a bradycardia, low systolic and diastolic blood pressure , reduced cardiac output and reduced heart size (Abel et al 1979).

Gastrointestinal tract

Achlorhydria and diarrhoea are frequent. There is a reduction in organ size, associated with villous atrophy and brush border enzyme deficiencies.(Betzhold et al 1984). Hepatosecretory proteins are all reduced in patients suffering from PEM. Low levels of plasma proteins in patients presenting for major surgery(Young et al 1981) have furthermore been correlated with many other indices of malnutrition.

Wound healing

Using a new method to assess the wound healing response it has been shown that early PEM is associated with an impaired wound healing response similar to that seen in patients with severe weight loss (Haydock et al 1987).

Immune function

PEM is frequently associated with an acquired immune deficiency(Suprina et al 1984) Severe immune deficiency is more

frequently associated with Kwashiorkor. In Marasmus the serum albumin levels are better maintained and the immune function appears to be less severely affected. (Bistrain et al 1977).

Part v : The High Risk Surgical Patient - A Problem of Identification

It has been claimed that various indices of nutritional state will identify patients who have a high risk of developing post-operative complications. Hence these indices would be useful for selection of candidates for pre-operative nutritional support (Buzby et al 1980; Mullen et al 1980; Rainey et al 1983). Profound weight loss (Studley et al 1936), some anthropometric indices (Hickman et al 1980; Klidjian et al 1980), tests of muscle function (Klidjian et al 1980) and measurements of plasma proteins (including albumin, transferrin, prealbumin and combinations of these) (Hickman et al 1980; Pettigrew et al 1986; Mullen et al 1980) have all been used as indicators of increased surgical risk. Recently Pettigrew et al, 1986 examined these indices more closely and it would appear that weight loss and a variety of anthropometric indices are not clear indicators of risk, whereas measurements of grip strength and low levels of plasma proteins are, to some extent, indicators of post-operative risk. Furthermore, it has recently been shown (Windsor et al 1988) that a thorough clinical examination which assessed major organ function proved to be as effective as any other indicator in identifying subjects at risk (Pettigrew et al 1986).

Part vi : The Effect of Nutritional Repletion

"Thy food shall be thy remedy" - (Hippocrates 400 BC)

There are body compositional studies that demonstrate that nutritional therapy result in a rapid accumulation of fat and glycogen and a slower accumulation of protein (Hill et al 1978). These effects only occur after weeks and months. Nevertheless there are some potentially useful effects of short term intravenous nutrition (IVN) which have been recently demonstrated. With adequate energy intake metabolic expenditure rises, liver and muscle glycogen are restored and body fat is laid down (Hill et al 1984). There is a partial restoration of type II muscle fibres which may be associated with increased muscular endurance (Church et al 1984; Russell et al 1983). There is some evidence that malnourished patients will have improved ventilatory function following short term nutritional repletion (Rochester et al 1984).

The effect of short term IVN on wound healing has been examined and it appears that the wound healing response returns to normal in some patients after 1-2 weeks of IVN (Haydock et al 1984).

There is now good evidence (Hill et al 1989) that the changes in protein stores that occur following two weeks of IVN depend on the relative effect of two competing processes: protein depletion and metabolic stress. With moderate to severe protein depletion (30% depletion of body protein stores) there is a marked tendency to gain protein with IVN. When the patient is post-operative stressed or septic, this tendency for protein gain may be reversed.

In conclusion there is experimental data that appears to show improvement in a number of organ functions over a period of 1 - 2 weeks of IVN. However, in the presence of continuing sepsis, positive nitrogen balance is not achieved and there seems to be a less favourable benefit on organ function.

Effect on Nutritional Therapy on Surgical Outcome

There have been a number of prospective studies (Williams et al 1977; Muller et al 1982; Holter et al 1977; Mullen et al 1981) examining the efficacy of pre-operative IVN in reducing post operative complications in patients undergoing major gastrointestinal surgery. The overall conclusion of these studies is consistent with the previous experimental data and suggests that some malnourished patients will benefit from 1 - 2 weeks of IVN. The proportion of patients that will benefit from nutritional support is however small - Hence one of the main problems we face currently is selecting which patients should receive nutritional therapy.

CHAPTER 2 ;THE PATIENT WITH INFLAMMATORY BOWEL DISEASE

Part 1 Background

The term Inflammatory Bowel Disease (IBD) refers to two chronic inflammatory disorders of the gastrointestinal tract;- Crohn's disease and ulcerative colitis.

Crohn's Disease

This disease was first described as an entity in 1932 by Crohn, Ginsberg and Oppenheimer. It was initially felt to be confined to the ileum, but later the small bowel (regional enteritis) and in 1960 Lockhart-Mummery and Morson confirmed its presence in the colon. It is an inflammatory condition involving all layers of the bowel wall (Whitehead 1980; Williams 1964). Macroscopically the features include;- thickening of the bowel wall, narrowing of the bowel lumen, discontinuous or skip lesions, together with discrete or confluent ulceration with deep fissures and/or fistula.

Anatomically more than two thirds of patients have small bowel disease, but the colon is also involved in a similar proportion. The prevalence of Crohn's disease varies on average between 10-70 cases per 100,000. The disease is most common in people of European origin and is 3-8 times more common in those of Jewish origin (Gilat et al 1979).

The aetiology of Crohn's disease is unclear. Some have suggested

an infectious aetiology (Cave et al 1978), and tissue infiltrates have been shown to cause cytopathic effects in tissue culture (Gitnick et al 1979). No transmissible agent has ever been isolated.

Some investigators have suggested a cell mediated aetiology but it remains uncertain whether the changes described are important aetiologicaly or whether they relate to the disease itself.

Smolen et al 1982; Rena et al 1980; Rossen 1980; have provided evidence for a genetic basis.

Diet has also been considered as a causal factor but there is no data directly linking this or other environmental factors to the disease.

The natural history of Crohn's disease is extremely variable. Nevertheless, the picture is one of diarrhoea with colicky abdominal pains in the majority and gradual worsening symptoms over a period of years.

Once the disease has progressed to the stage of necessitating surgery, subsequent recurrence is common.

Complications from this disease are common and 10 -20 % of patients die from their illness.

The most common complication leading to surgery is intestinal obstruction secondary to a stricture.

Fistula formation may occur leading to sepsis and malabsorption.

Anaemia is common through persistent mild haemorrhage as are arthritis and disorders of the eye, skin, mucous membrane and liver.

Renal disorders are not uncommon. In addition to urinary tract infections, secondary to enterovesical fistulas, bowel inflammation may involve the ureters with subsequent obstruction. Oxalate stones secondary to hyperoxaluria have been related to steatorrhea (Dobbins et al 1976). Following surgery (the presence of ileostomy) uric acid stones are common. In one series; an incidence of 18% (Gelzayd et al 1968) compared to 3.8% in the normal population (Scott et al 1977). The risk of calcium oxalate stones is also increased (Bamback et al 1981).

Ulcerative Colitis

This is a similar chronic inflammatory disease of unknown aetiology. It chiefly affects the mucosa of the rectum and left colon.

It was first described in 1875 by Wilks and Moxon. The incidence of ulcerative colitis is approximately 4 per 100,000 again it is higher in those of Jewish origin (Bonneure et al 1968). It occurs between the third and sixth decade.

As with Crohn's disease, the cause is unknown. An infectious agent would seem likely but there is no good evidence implicating agents such as chlamydia, cytomegalovirus, or yersinia in the pathogenesis of ulcerative colitis (Taylor-Robinson et al 1979, Swarbrick et al 1979). Several studies have attempted to associate toxin from clostridium difficile (the agent responsible for pseudomembranous colitis), with relapses of IBD (Bolton et al 1980)

There are more cases of ulcerative colitis in families of patients

with the disease (10-15%) than in families of control patients - although data suggesting a genetic hypothesis is far from complete.

Ulcerative colitis is an inflammatory disease confined to the mucosa with the primary lesion being the crypt abscess. Lateral extension and coalescence of crypt abscesses may undermine mucosa leaving an area of ulceration and the formation of pseudopolyps. Although generally confined to the mucosa, severe disease may extend through the deeper muscular layers predisposing to dilatation, perforation or stricture.

The clinical course of ulcerative colitis is highly variable. The onset of the disease may be insidious or abrupt. The symptoms may range from small amounts of rectal bleeding to fulminant diarrhoea with colonic haemorrhage and prostration. Most patients (60-75%) will have intermittent attacks and symptomatic remissions between attacks (Edwards et al 1964). 5-15% of patients will be troubled by continuous symptoms without any remission.

Part ii : Mechanisms of Malnutrition in Patients with Inflammatory Bowel Disease

Diminished Food Intake

Diminished food intake plays a chief factor in causing malnutrition in patients with IBD. Dietary restriction occurs voluntarily by the patient to avoid abdominal cramps or lessen the diarrhoea. It may be imposed by medical staff to control symptoms or allow diagnostic procedures.

Malabsorption

Malabsorption is present in those patients who have extensive mucosal involvement or have undergone a major bowel resection. It is chiefly seen with fat and fat soluble vitamins (Beeken et al 1975). Bile salt malabsorption will also be present in this group of patients due to depletion of the bile salt pool (Heaton 1977).

Increased intestinal secretion with nutrient loss

A protein losing enteropathy is a prominent feature of both active Crohn's disease and ulcerative colitis. Buckell et al 1977, measured the faecal protein in 50 colitics and observed losses of up to 26gm/day in acute colitis compared to 1 gm/day in normal controls.

Florent et al 1981, observed a linear relationship between intestinal protein loss and the Crohn's Disease Activity Index (CDAI). This increased protein loss soon exceeds the livers ability to synthesise protein leading to hypoalbuminaemia.

There are also losses of blood, electrolytes and trace elements in the lumen of the gut. This leads to anaemia, hypokalaemia, hypomagnesaemia and zinc depletion. (Wolman et al 1979).

Drug Nutrient Effects

While the judicious use of drug therapy may help control symptoms in most patients and thereby improve well being and even dietary intake, many of the drugs in common use by these patients have negative effects on nutritional metabolism. Corticosteroids can exert an additional catabolic effect on patients who may already be under stress.

Energy and Protein Utilisation

Many patients with IBD are metabolically stressed and hence may well have increased nutrient requirements. Certainly this is true in the presence of frank infection, abscess or fever.

It has previously been shown that it is impossible to achieve a positive nitrogen balance in the presence of an undrained intra-abdominal abscess. Whole body protein turnover was measured in 19 patients with IBD following an intravenous tracer dose of ¹⁵N-glycine (Powell-Tuck et al 1984). The results showed a correlation between the rate of protein catabolism and disease severity.

In another study (Hill et al 1988), massive protein losses of 2% per day were noted in septic patients, despite IVN. Furthermore in the same study, even despite drainage of the sepsis the Crohn's fistula patients failed to achieve positive nitrogen balance.

Part iii Prevalence of Nutritional Deficiencies in Inflammatory Bowel Disease

Despite the limitations of nutritional assessment there has already been a high prevalence of nutritional deficiency in hospitalised patients previously noted. The situation with ambulatory patients is however less clear.

(Driscoll et al 1978).:-

<u>Evidence of Macronutrient Deficiency</u>	<u>Prevalence %</u>
Weight loss	65-75
Growth retardation	40
Hypoalbuminaemia	25-80
 <u>Micronutrient Deficiency</u>	
Anaemia	60-80
Iron deficiency	40
Low vitamin B12	48
Low serum folate	54-64
Low serum magnesium	14-33
Low serum potassium	6-20
Low serum vitamin A	21
Low serum vitamin C	12

Low serum 25-OH-vitamin D	25-65
Low serum zinc	40-50
Vitamin K deficiency)
Low serum copper) all
Metabolic bone disease)described
Pellagra)but no
Vitamin E deficiency)frequency
)given

Protein Energy Malnutrition

PEM is the most common nutritional deficit in hospitalised patients. This presents as weight loss in adults and growth retardation in younger patients.

High prevalences of weight loss range from 60-80% in large series of hospitalised patients (Rosenberg et al 1985; Van Patter et al 1954; Mekhjian et al 1979). Harries et al 1982 found 20% of an unselected consecutive group of ambulatory patients to be significantly underweight. Similarly Lanfranchi et al 1984 found 40% of out-patients with Crohn's disease were significantly underweight and had similar reductions in anthropometric measurements.

Similar weight losses have been described in patients with active ulcerative colitis (Goligher et al 1968).

Investigators have found that mid-arm circumference of the non dominant upper limb is a very useful nutritional marker in these patients. Not only does it correlate with body weight but also other nutritional markers, eg., albumin, prealbumin, ferritin,

calcium and lymphocyte count. (Harries et al 1982; Harries et al 1984; Heatley 1986).

The nutritional state of these patients is dependant on the clinical presentation. Major nutritional depletion was found in the groups requiring urgent surgery, or sustaining a major complication. (Hill et al 1977b).

Standard nutritional indices may be successful in detecting a severe degree of PEM, but less sensitive at detecting early nutritional deficits. (Ward et al 1982; Blackburn et al 1977).

It is interesting that Cooper et al 1986, and Turnberg et al 1978, when examining the body composition of fully convalescent patients after panproctocolectomy found a permanent subclinical reduction of the fat free body mass and total body protein of these patients. This work is certainly at variance with the earlier study of Hill et al 1977b and furthermore is inconsistent with the clinical appearances of these fully convalescent patients.

Electrolyte and Mineral Deficiencies

Potassium - reductions in total body potassium have been found in patients with active Crohn's disease. This reduction was found to be well correlated with disease severity (Lehr et al 1982).

Hyponatraemia and hypochloraemia-reductions have have frequently been found in patients with Crohn's disease (Kiefer 1955; Beeken 1975). Using isotopic techniques Clarke et al 1967 reported an 11% reduction in total body water and a 7% reduction in total exchangeable sodium in 21 ileostomy patients compared with healthy

controls and these findings were later confirmed by Hill in a similar study (Hill et al 1975). However, in the two more recent studies (Cooper et al 1986; Turnburg et al 1978) reductions in total body water and extracellular fluid were not found. Clearly there is a need to clarify this situation.

Magnesium - Symptomatic hypomagnesaemia has been reported in Crohn's disease (Gerlach et al 1970, Beeken 1975, Main et al 1981) This problem is especially seen after extensive small bowel resection with chronic diarrhoea.

Calcium - Hypocalcaemia is often present in patients with IBD. It often reflects hypoproteinaemia, but it also reflects decreased intake, loss of absorptive surface, loss secondary to steatorrhoea and concomitant steroids. (Ladefoged et al 1980; Krawitt et al 1976; Kimberg et al 1971).

Fat Soluble Vitamin Deficiencies

Malabsorption of fat soluble vitamins is common in Crohn's disease and includes Vitamin A deficiency, vitamin D and K (Main et al 1983).

Water Soluble Vitamin Deficiencies

Folic acid deficiencies are variably reported in patients with IBD ranging from 5% (Beeken 1975) to 63% (Franklin et al 1973). Vitamin B12 absorption strongly correlates with the extent of terminal ileal disease (Gerson et al 1973).

Trace Element Deficiencies.

Iron deficiency anaemia is common secondary to chronic blood loss (Lehr et al 1982, Hellberg et al 1982).

Zinc deficiency in Crohn's disease is chiefly due to gastrointestinal loss secondary to diarrhoea. Significant reductions in plasma and hair zinc have been documented particularly in children with Crohn's disease and growth retardation. (Solomons et al 1977).

Part iv Management of patients with Inflammatory Bowel Disease

No single therapeutic regimen should be considered routine for any individual patient with IBD. Nevertheless there are 4 aspects to management:-

1. General supportive measures
2. Treatment with anti-inflammatory and immunosuppressive agents directed against the disease process itself.
3. Management of the patients nutritional status, including careful nutritional assessment and enteric and parenteral administration of nutrients.
4. Surgical intervention.

In the following section I will review aspect 3 - nutritional management in detail after discussing the other three.

General Supportive Measures

Symptomatic measures are required for patients with acute exacerbations. These include bed rest, analgesia and careful correction of fluid and electrolyte abnormalities and correction of anaemia.

Anti-inflammatory and Immunosuppressive Agents

Steroid therapy plays a major role in the treatment of symptomatic relapse of Crohn's disease (Summers et al 1979). Unfortunately large doses of steroids are frequently necessary for long periods

with a high rate of unacceptable side effects. (Singleton et al 1979). There is no evidence that the frequency of recurrence or long term outcome is altered by maintenance steroid therapy.

Sulfasalazine has been used frequently in the treatment of patients with symptomatic Crohn's disease.

In the large National Cooperative Crohn's Disease Study Sulfasalazine appears to be as effective as Prednisolone in diminishing the activity of disease (Summers et al 1979)

Immunosuppressive agents - Azathioprine and 6-mercaptopurine have been used with success to suppress both the intestinal symptoms and extraintestinal manifestations of Crohn's disease in the steroid refractory patient. (Nyman et al 1985; O'Donoghue et al 1978).

Controlled trials have also demonstrated that steroids similarly increase the incidence of complete remission in the initial attack or during an acute exacerbation of ulcerative colitis. (Truelove et al 1955)

Follow up studies show that the benefits of a short course of steroids were transitory (Truelove et al 1955). Other studies indicate that maintenance doses of steroids are not useful in prolonging the remission (Truelove et al 1959; Lennard-Jones et al 1965a) and hence the question of the most effective form of maintenance therapy is still open and the long term benefit of steroid therapy has not been adequately assessed.

Sulfasalazine has been found useful to achieve remission in patients with mild colitis (Lennard-Jones et al 1960).

Furthermore once remission has been achieved by corticosteroid

therapy, sulfasalazine appears to reduce the frequency of subsequent relapse (Lennard-Jones et al 1965b). Azathioprine appears to have no role in most cases of ulcerative colitis.

Surgery for Inflammatory Bowel Disease

Unlike ulcerative colitis, the prognosis after operation for Crohn's disease, is never sure. This is because of its high rate of recurrence following resection of diseased bowel. Surgery is only indicated when the patient becomes incapacitated by symptoms or is suffering from recurrent or sustained intestinal obstruction or when an inflammatory mass is present together with fistulas.

Surgery is often followed by a good deal of immediate post-operative morbidity not to mention a 50% recurrence rate at 15 years. Resections followed by re-resection may lead to a variable amount of intestinal malabsorption.

Elective surgical treatment for Crohn's disease affecting chiefly or entirely the large bowel, is usually colectomy with an ileorectal anastomosis or ileostomy and complete proctocolectomy in the presence of rectal disease.

For emergency treatment of Crohn's colitis, ileostomy and subtotal colectomy would be the procedure of choice.

Ulcerative colitis surgery is generally indicated in 5 general situations. Refractory severe colitis, refractory chronic disease, steroid dependence, growth retardation and or to prevent colitis related cancer.

For many years the accepted elective surgical treatment for ulcerative colitis was ileostomy and complete proctocolectomy.

This operation was highly effective in curing the disease but its major drawback was the permanent stoma - Admittedly with modern ileostomy care the disadvantages of a stoma can be markedly reduced but it is understandable that patients with colitis who are young should be strongly attracted to alternative forms of operation which may avoid a stoma. During the past 8-10 years there has been a dramatic swing of surgical fashion towards the more frequent use of these variants. Without question, the enthusiastic revival of interest in the old NISSEN/RAVITCH operation of proctocolectomy with ileoanal anastomosis is chiefly responsible for the recent change in colitis surgery fashion.

What has helped to secure the success that eluded it previously has been the incorporation in the technique of construction of a pelvic ileal pouch which has reduced the severity of initial diarrhoea and improved continence. During the past 8 years this operation has been exclusively used in several centres and has been shown to be safe and provide good functional results (Beck et al 1986).

For acute colitis, ileostomy and subtotal colectomy is the preferred procedure. It has the advantage of being easy to perform and also preserves the rectum.

Management of the Patient's Nutritional Status

In the previous section I have already indicated the high prevalence of nutritional deficiency in patients with IBD.

It is not surprising therefore that the overall therapeutic strategy has been to ensure adequate intake of nutrients while modifying dietary intake to decrease gastrointestinal symptoms.

Both Intravenous nutrition (IVN) and Enteral Nutrition (EN) may improve nutritional status as determined by body weight, anthropometry, nitrogen balance, serum proteins and total body nitrogen (Vogel et al 1974; Dean et al 1976; Mullen et al 1978; Elson et al 1980; Dickinson et al 1980; Muller et al 1983; Meryn et al 1983; Jacobson et al 1984; Ostro et al 1985; Voigt et al 1973; Rocchio et al 1974; O'Morain et al 1980; Lochs et al 1984; O'Morain et al 1984).

In addition both IVN and EN have been previously shown to improve linear growth in children and young adults with growth retardation. (Morin et al 1980; Navarro et al 1982).

As malnutrition has been long associated with increased morbidity it has been suggested that nutritional repletion should result in decreased operative morbidity.

This question has not been addressed however, in a controlled trial specifically in patients with IBD. However, one trial (Dickinson et al 1980) studied 27 patients with ulcerative colitis and 9 patients with granulomatous colitis (all undergoing acute exacerbations). Patients were treated with Prednisolone, bed rest and intravenous fluids. 19 patients were randomised to receive total parental nutrition while the remaining 17 received

an ad lib hospital diet. Mortality (0/19 vs 1/17), ultimate surgery (9/19 vs 6/17), and recurrence rates (8/19 vs 7/16) were all apparently unaffected by the administration of IVN.

There is to date no controlled trial evaluating nutritional support as primary therapy in Crohn's disease. IVN and EN are generally widely used only after conventional treatment has failed. They are used in conjunction with other medical treatment and furthermore there is no consensus on what constitutes medical failure. The definitions of remission have been subjective and imprecise but often refer to the ability to avoid surgery during that exacerbation.

Retrospective and uncontrolled prospective studies of IVN in Crohn's disease have reported hospital remission rates of 23-100% in patients receiving 3-6 weeks of IVN and long term remission rates of 19-72% (Vogel et al 1973, Dean et al 1976; Mullen et al 1978, Fischer et al 1973; Fazio et al 1976; Reilly et al 1976; Bos et al 1980; Ostro et al 1985).

There have been only 2 prospective randomised controlled trials of IVN in Crohn's disease. In the earlier study of Dickinson et al 1980; the number of patients was too small to draw conclusions. Greenberg et al 1988, have reported the results of a prospective trial in which Crohn's patients who failed conventional medical management were randomised to receive 3 weeks of IVN, defined formula diet (EN) or an oral diet with partial parenteral nutrition (PPN). The 3 groups did equally well with hospital remission rates between 58% and 71%. Since the follow-up periods of the groups were not stated, meaningful comparison of the long

term remission rates can not be made. It can however be concluded that bowel rest is not essential in reducing remission in refractory Crohn's patients.

The long term remission rate is not clear since each study has a different follow up period. Nevertheless the long-term rate varied from 17-77% with follow-ups, ranging from 3-120 months.

Greenberg's recent paper goes far to disprove the theory that bowel rest can promote healing of the bowel through reducing intraluminal antigenicity (Matuchansky et al 1986; Rhodes et al 1986).

There is now increasing evidence that glutamine is essential for the normal structure and function of the intestine (Souba et al 1985). The lack of glutamine in IVN solution, together with the complications of IVN use even in specialist centres (Ang et al 1986) makes IVN use possibly disadvantageous in some of these patients.

There are fewer studies examining the effect of IVN in the management of ulcerative colitis (Vogel et al 1974; Dean et al 1976; Mullen et al 1978; Elson et al 1980;; Dickinson et al 1980; Fischer et al 1973; Fazio et al 1976; Reilly et al 1976). There has been only one randomised prospective study (Dickinson et al 1980) and this indicated no beneficial effect of IVN. The main difficulty again relates to standardisation of disease severity. This explains the variation in the remission rates (9-80%). Nevertheless, when all studies are considered the average remission rate is a little more than 41%.

Elemental diets given orally or through a nasogastric tube have

also been used as a treatment for both Crohn's disease (Voigt et al 1973; Rocchio et al 1974; O'Morain et al 1980; Lochs et al 1984; O'Morain et al 1984; Axeleson et al 1977) and ulcerative colitis (Rocchio et al 1974; Axeleson et al 1977).

O'Morain et al 1984, randomised 21 patients to conventional (steroid) therapy or an elemental diet. The patients had equivalent short term remission rates.

When all reported studies are combined the overall short term remission rates in Crohn's disease treated with an elemental diet is 64%. This figure is similar to the overall hospital remission rate for IVN treated patients of 59%.

Few studies have examined the effect of elemental diets in acute ulcerative colitis. The reported hospital remission rate is about 34%, similar to the 41% overall rate reported with IVN.

In summary IVN and EN have been used to treat Crohn's disease and ulcerative colitis patients both as primary therapy modalities, but more often as a back up when conventional medical therapy has failed. The expense and complications of IVN, and to a lesser degree EN, necessitate the design of trials to prove or disprove the efficacy of these therapies. IVN and EN should be considered potentially valuable but largely unproven adjuncts to conventional medical therapy in terms of trying to achieve remission in the presence of acute exacerbations of these two diseases.

Enterocutaneous, colocutaneous and enterovesical fistulas have all been treated with IVN and EN.

Unfortunately the success of nutritional intervention in the healing of fistulas has been difficult to estimate and generally

disappointing.

First, there have been no randomised trials comparing IVN or EN with standard medical therapy.

Furthermore most studies have reported total fistula healing rates regardless of whether fistula arise de novo or post-operatively. It would be anticipated that post-operative fistulas would have a much higher healing rate since the communicating bowel would usually be macroscopically normal with no distal obstruction.

Three IVN studies reported an in-hospital fistula healing rate of 49% (34/70) with a permanent healing rate of 35% (24/68) (Elson et al 1980; Muller et al 1983; Ostro et al 1985). These percentages are reasonably similar to those of the earlier literature reviewed by Driscoll et al 1978 who found a 43% hospital healing rate and a 30% long term healing rate.

More recently Hill et al 1988, reviewing 28 patients with Crohn's fistula found that spontaneous healing was much less than in earlier reports. For the 10 fistulas arising in the post-operative period from the small intestine wall, with no macroscopic evidence of Crohn's disease, 4 fistulas healed spontaneously and 6 required surgery.

Of the remaining 16 patients the fistulas developed in the early post-operative periods either from an anastomosis where some remnant of the disease remained or from another area of diseased bowel. None of these fistulas healed spontaneously with IVN.

Hence, whether IVN or EN actually improves fistula healing rate over conventional therapy is debatable. The data suggests that

IVN may cause long term healing in up to one third of patients - these patients represent however that group where fistulas had arisen from macroscopically normal bowel.

Finally, IVN or EN has been used for those patients with IBD who through surgery or extensive disease are left with a severe short bowel syndrome. A number of these patients have received IVN for long periods. Fleming et al 1977, has indicated the efficacy of this treatment.

CHAPTER 3 : SUMMARY AND AIMS OF THESIS

Summary It is clear from this introduction that patients suffering from IBD uniformly suffer varying degrees of PEM. The severity of this PEM in the various clinical presentations is not known accurately. Previous studies have relied heavily on indirect measurements of nutritional status and furthermore little is known of the nutritional status of the ambulatory patient with IBD and confusion still exists over the long term nutritional changes following colectomy for colitis.

Whether IVN should be prescribed in patients admitted to hospital for acute exacerbations of IBD still remains contentious. There is to date no evidence that IVN leads to either a lowering of post-operative morbidity or that it promotes clinical remission. Recent work (Windsor et al 1988), suggests that the clinical significance of PEM relates to its associated impairment affecting many organ systems eg., respiratory muscle function.

There is data to suggest that nutritional therapy may result in improvement in many of these physiological functions long before there is any measured change in the patients nutritional status. It would therefore seem reasonable to examine the efficacy of IVN for this group of surgical patients in terms of changes in these clinically important physiological functions.

Aims of Thesis

In the following chapters I will

1. Examine the problem of PEM by using direct measurements of body composition. In particular I will measure the changes in total body protein, total body fat and total body water in the various clinical presentations of IBD.

2. I will examine the longitudinal changes in total body protein, fat and water following surgery for colitis. Work will also be directed at measuring the water in 2 groups of convalescent patients: Ileostomy vs J-pouch to determine whether the superior functional results following J-pouch confer any body compositional advantage. I will re-examine the widely accepted principle that ileostomy patients have an increased risk of developing urinary calculi and relate this to the relative risks of stone formation following J-pouch.

3. I will assess in a group of patients suffering severe exacerbations of IBD, the effect of a 14 day course of IVN, on skeletal muscle function, respiratory muscle function, hepatosecretory function, wound healing and psychological function along with the changes in body composition.

SECTION 2 : METHODS

CHAPTER 4 : EVALUATION OF WEIGHT LOSS

Throughout this thesis weight loss was determined simply as remembered well weight - current measured weight. The accuracy of this result therefore depended on the accuracy with which the original weight could be estimated by the patient. Weight is however nearly unique in that it is a measurement that many people make on themselves. Therefore many patients can give some estimate of their weight when they are well and there is good evidence that this estimate is reliable and accurate (Stewart 1982). An alternative to recalled weight is predicted or standard weight. This is the mean weight of a group of healthy persons of the same age, sex and height as the patient and is usually taken from published tables. However, for individual patients it is important to realise that it is subject to large errors since it makes no allowance for the wide variation of individual weights about the mean. Furthermore as in the case of the patients in my clinical studies, they were chiefly young patients and they had suffered very long periods of chronic illness. For example in section 5 my 19 patients had a mean age of 30 +/- 12 SD years and had a mean duration of illness of 6 years, with a range of 6 months - 19 years. Hence a predicted well weight would be especially inappropriate for them. It has now been clearly shown that it is more reliable to estimate weight loss by using the patients recalled well weight than by using published tables

(Morgan et al 1980).

CHAPTER 5 : ASSESSMENT OF BODY COMPOSITION

Part 1. Total Body Protein

Body composition analysis was based on a five compartment model of the human body (Beddoe et al 1984, Beddoe et al 1985). Total Body Protein (TBP) was calculated from direct measurement of total body nitrogen (TBN) made by in vivo neutron activation analysis (IVNAA). This technique relies on the unique association of the element nitrogen with protein in the human body. In particular

$$\text{TBP} = 6.25 \text{ TBN}$$

Anderson (and colleagues 1964) pointed out in 1964 that measurement of TBN would allow assessment of muscle wasting and malnutrition.

TBN can be measured by two IVNAA methods namely the delayed gamma method and the prompt gamma method.

Delayed gamma IVNAA depends on the $^{14}\text{N} (n,2\text{N}) ^{13}\text{N}$ reaction which requires exposure to neutrons of a very high energy (greater than 11.3 MeV). Monitoring the reaction is achieved by measuring the 0.15 MeV gamma rays from subsequent positron annihilation. On the other hand, the prompt gamma method depends on the $^{14}\text{N} (n,\gamma) ^{15}\text{N}^*$ reaction: $^{15}\text{N}^*$ de-excites very quickly (10^{-15} second life time) to stable $^{15}\text{N}^*$, emitting a range of gamma rays of which the 10.8 MeV gamma is the one monitored.

The value of either IVNAA technique over conventional nitrogen balance is primarily that it affords an estimate of total body protein at any given time, where balance techniques can only

provide net changes in total body protein. Moreover, IVNAA is logistically more suitable over long study periods and does not in principle suffer from the cumulative systematic errors that almost inevitably occur with the nitrogen balance technique .

The system constructed at Auckland see Figure I was developed for assessment of body composition in critically ill surgical and intensive care patients. It consists of two 7.6 Ci Pu-Be sources (neutron output 2.2×10^7 neutrons per second per source) placed above and below the subjects who lie supine on a scanning couch. To 5 x 4 inch NaI gamma ray detectors are placed such that their axes are orthogonal both to the scan axis and to the beam axis.

The subject is slowly scanned through the neutron beam and composite gamma ray spectra over the trunk and upper leg regions are collected by conventional pulse height analysis, the whole scan taking a total time of about 36 minutes. The precision of the estimate of total body protein was measured by repeated scanning of an anthropomorphic phantom containing physiological concentrations of the major body elements. This was ± 0.30 kg ($\pm 2.6\%$ of total body protein in reference man (Reference Man 1975) / An analysis of two human cadavers gave excellent agreement in the measurement of body nitrogen between chemical and neutron activation analysis, to within 40 g (2.7%) in one and 4 g (0.6%) in the other (Knight et al 1986).

Part ii : Total Body Water

Ten millilitres of a stock solution containing tritiated water (THO) in a concentration of 10uCi/ml were drawn up into a 10 ml

syringe. The needle was then changed and the full syringe with needle and cap attached was then weighed together with a size 21g butterfly needle with protective cover on a precision balance. The THO was then injected intravenously through the new needle and through the butterfly needle (following a baseline venous sample for tritium, and plasma proteins 20(mls)).

The empty syringe was then weighed with needle and cap attached together with butterfly and cover. The mass of the THO stock administered was obtained by subtraction.

A 20 ml sample of venous blood was taken from the opposite arm 2½ hours later. The blood was centrifuged and the serum removed. Aliquots of serum were assayed for THO by scintillation counting. Serum water concentration was obtained by weighing a sample of serum before and after drying to constant weight. All tritium counts were assumed to have derived from the water in the serum sample. Standards of stock solution were assayed in sextuplicate, subjects serum samples in triplicate. The precision of this method involves a random error in weighing the syringe, dilution of stock solution for assay, determination of serum water, counting statistics in both standards and samples and pipeting of both standards and samples prior to scintillation counting. The overall precision was estimated at 1%-2% standard deviation for total body water (TBW) (+/- 0.6 kg, ie 1.5% of water of reference man).

Total body water was assumed to be the space into which the THO was distributed and no correction has been made for non-aqueous exchangeable hydrogen.

Part iii : Total Body Minerals

The total body mineral (TBM) compartment was small compared to the three major compartments and could be estimated with sufficient accuracy by assuming that it represented a constant fraction of the FFM in normal individuals. The mineral and glycogen compartments was assumed to be linearly related to skeletal size (product of height, mediastinal thickness and biacromial diam) according to a regression equation derived in normals ($r = 0.91$, $CV = 8.5\%$) (Beddoe et al 1984). It has been previously shown that errors in the estimates of the mineral and glycogen compartments propagate (in quadrature) to very small errors in FFM.

Part iv : Fat Free Body Mass

The FFM was derived by adding TBP and TBW together with the estimated total body minerals and glycogen; FFM having a typical precision of $\pm 1.6\%$.

Part v : Total Body Fat

Total Body Fat was estimated as the difference between body weight and the sum of total body water, protein, minerals and glycogen (FFM). The precision of the estimate was ± 0.8 kg ($\pm 6.4\%$ of fat in Reference Man) and was most affected by the measurement of TBW. In the analysis of the cadavers, the different estimates, relative to chemical measurements of TBF, were high by 0.23kg in the first and low by 0.94 kg in the second (Knight et al 1986)

Of all the major body compartments the most elusive to measure in the living subject is undoubtedly TBF. We are still dependant on its measurement though indirect means including densitometry (usually underwater weighing), skinfold anthropometry, imaging techniques (X-ray radiometry - computer scanning), electrical conductivity or impedance measurement and finally the method we employ ie the measurement of other major compartments and subtraction of these from measured body weight(the so called difference method)

Densitometry the use of densitometry to estimate body fat utilises the physical principle that body fat is much less dense than the other compartments of the body and secondly and more importantly on the assumption that variations in body density are the result of variations in body fat content. This implies that the density (D) of the fat free body mass is assumed to be constant and therefore that

$$\frac{M_f}{M} \propto \frac{1}{D}$$

Where Mf and M are the mass of fat and body mass respectively. The most commonly used equation is that proposed by Siri et al 1956.

$$\frac{M_f}{M} = \frac{4.95}{D} - 4.50$$

Which assumes densities of 0.90 and 1.100g/cc for fat and fat free mass respectively. Since this is an indirect method of measuring body fat, there are biological as well as technical sources of error that affect the precision and accuracy of the calculated body fat. Siri calculated that the variation in density of fat and the lean body mass (LBM) would give rise to a precision standard deviation in the estimate of fat in normal man of the order of 3.8% of body fat. However, the possibility of important systematic errors arising from the underwater technique should not be underestimated. (Buskirk 1961). Furthermore it will be stressed later in this chapter that the density of FFM varies not only in surgical patients but even in well volunteers. Finally underwater weighing would be inappropriate for most patients purely for logistical reasons.

Skinfold anthropometry

The proportion of Body Fat stored in the subcutaneous compartment is quite variable. According to Lohman (1981) estimates by various investigators range from 20 to 70 percent depending on factors such as age, sex, obesity and measurement technique.

In clinical practice measurements can be reliably made only in two or three sites and these usually include biceps and triceps skinfolds with or without subscapular skinfold.

There have been many equations relating body density to functions involving skinfold thickness at one or more sites. The more widely used sets of regression relationships is that reported by Durnin

and Womersley 1974;

$$D = C - m \text{Log}_{10} \left(\sum_i S_i \right)$$

Where S_i is the mean measured skin fold thickness at a specified site and where C and m are the tabulated linear regression constants. The error on the estimate of body fat for a typical individual however using this method is around 24%. Furthermore it should be emphasised that the above computations assume that the relationship between density and total body fat is free from biological imprecision which is not the case since the density of the lean body varies considerably owing to variations in hydration, minerals and protein between individuals.

Hence it is clear that skinfold anthropometry has no place in body composition and similarly it is unsuitable for measurements of body fat in individuals or small groups. This would be especially true of patient studies in which major changes in body composition are suspected.

Imaging techniques Computerised tomography would allow calculation of the total fat. Its major limitations however are its costs and the necessary radiation dose.

Electrical conductivity In this technique (Harrison et al 1982, Presta et al 1983) the differential conductivity of fat and lean tissue is exploited with the latter displaying better conductivity owing to its greater electrolyte concentration. Measurement of total body electrical conductivity (TOBEC) can be achieved by placing the subject in a large solenoidal coil driven by a 5HZ

oscillating radio frequency current; impedance measurement can be used to derive conductivity, which is a function of lean body mass.

To date validation of the TOBEC method in human studies has been against densitometric estimates of lean body mass (Presta et al 1983) , consequently the method suffers from the same validation problem as other indirect techniques calibrated via densitometry. The advantages of this method are that it is rapid, reproducible, safe, non invasive, and applicable to most groups of hospitalised patients.

Difference methods Undoubtedly the most simple form of the difference method is the use of measured total body water (TBW) to determine the fat free mass (FFM) by the relation;

$$FFM = TBW/f$$

Where f is the assumed fraction of the FFM that consists of water; f is usually taken to be 0.73 for normal man based upon the studies of Pace and Rathburn 1945. Recent work by Streat et al 1985, has shown however that this ratio varies from 0.685 to 0.754 in normal subjects with a mean value of 0.729 and 0.67 to 0.83 (mean = 0.74) in a group of patients presenting for nutritional support implying that application of 0.73 will lead to gross errors in individual values of FFM or TBF and large systematic errors in the mean values of these entities.

It was Cohn et al 1981 using the technique of IVNAA who first considered several variables, TBW, determined by tritium dilution, TBF by IVNAA and bone mineral mass (BMM) by IVNAA. The FFM was considered to be the sum of these three entities so that TBF is

again obtained by the relationship $TBF = M - FFM$. It is important to note that in a large series of normal volunteers Cohn and colleagues found that skinfold anthropometry consistently underestimated TBF relative to their difference methods. A similar difference was confirmed with our own method using IVNAA and tritium dilution (Streat et al 1985).

Indeed our own work showed that under estimation of TBF is even greater in a group of patients presenting for nutritional support than in normal subjects.

Part vi ASSESSMENT OF PROTEIN DEPLETION

The measured values of TBP were compared with values predicted from multivariate predictor equations that related measured TBP to age, height, sex and weight. Hence the protein stores for a particular patient were expressed as a percentage of their predicted TBP on the basis of predictor equations developed locally (Beddoe et al 1985).

TBP was measured in 126 normal subjects and was regressed for each sex against the variable age in years (A), height in cm (H) and weight in kg (M) yielding the following regression equations.

$$\text{Males TBP (kg)} = 0.061H + 0.126M - 0.032A - 6.334$$

$$\text{Females TBP (kg)} = 0.095H + 0.067M - 0.018A - 10.631$$

The mean protein index for the normal volunteers was 0.99 +/- 0.11SD for females and 1.03 +/- 0.12SD for males.

Part vii ASSESSMENT OF FAT DEPLETION

The measured value of TBF were compared in a similar way with values predicted from multivariate predictor equations that related measured TBF to age, height and sex. Hence fat stores were expressed as a percentage of predicted.

$$\text{Males TBF (kg)} = - 0.165H + 0.72A + 36.44$$

$$\text{Females TBF (kg)} = + 0.0797H + 0.107A + 0.038$$

Part Viii RADIATION DOSE

The total radiation dose equivalent to each subject has been conservatively estimated as approximately 50 mREM, about 30 mREM maximum being from the neutron activation procedure (assuming a quality factor of 10) and approximately 20 mREM from the tritium (quality factor unity).

Part ix HYDRATION OF THE FAT FREE BODY MASS TBW:FFM

Throughout this thesis my index for the state of hydration was the value of the ratio TBW/FFM. In a previous study (Beddoe et al 1985) of 68 normal volunteers the mean value for TBW:FFM for 35 females was found to be 0.726+/- 0.015 (SD) with a range 0.692-0.757 and similarly for 33 males the mean value of TBW/FFM was found to be 0.711 +/- 0.012 (SD) with a range 0.688-0.729.

The precision of the TBW:FFM ratio was in practice largely affected by the precision in the measurement of protein (already discussed). This implies a precision in the ratio of the order of 1.5% as calculated for Reference Man. Clearly as far as the TBW:FFM ratio is concerned one can have confidence in individual values.

Part x MEASUREMENT OF EXTRACELLULAR WATER VOLUME (ECW)

The extracellular water volume (ECW) was determined by bromide dilution (Cheek 1953). 50 mls of a 5% sodium bromide solution were infused slowly over a 5 minute period following a background sample of 10 mls of intravenous blood. An estimate of the bromide space was performed on a 10 ml sample taken from the contralateral arm three hours following injection. The assay (Drongowski et al 1982) involved sample deproteinisation by adding a 1.0 ml of ice cold perchloric acid (0.6M) to 0.5 mls of sample. Following centrifugation at 2000 rpm at 4°C for 5 minutes 1 ml of supernatant was transferred to a test tube containing 1.0 ml of 0.6% sodium chloride and 1.0 ml of 0.0375% gold chloride. Absorbance was recorded with a spectrophotometer at 350 nm wavelength exactly 30 seconds after the addition of the supernatant to the NaCl-AuCl₃ solution. The spectrophotometer was zeroed with distilled water. The standards used in the assay were 5,10,15 and 20 mg% NaBr made up with distilled water. These standards produced a linear absorbance curve to a concentration of NaBr of 40 mg%. Corrected bromide space equaled:-

Amount of bromide administered

$$\frac{\text{Amount of bromide administered}}{\text{Bromide concentration in plasma}} \times 0.90 \times 0.95 \times 0.94$$

Bromide concentration in plasma

where 0.90 corrects for the amount of intracellular bromide, 0.95 corrects for the Donnan equilibrium and 0.94 corrects for the proportion of water in plasma.

Intra and interassay variation using this technique has been reported as extremely small correlation coefficient 0.995 (Drongowski et al 1982). In our own laboratory the precision for this analysis was +/- 3.4%SD.

A major problem however with this technique is one of interpretation:- It is quite clear from the literature as early as (Deane et al 1951) that intracellular chloride may exist in quite high concentrations even in health but certainly in states of illness it may range from 21.2-29.5 meq litre. Hence the old assumption that chloride is confined to the extracellular fluid (and hence defined by bromide dilution) has to be abandoned.

My measurements of ECW employed in two of the clinical studies therefore may suffer from these interpretation problems. Certainly one can only consider grouped data and even then the ECW:FFM ratio must be considered only as an adjunct to the more precise TBW:FFM ratio.

Part xi TOTAL BODY POTASSIUM (TBK)

A shadow shield counter has been built recently in our department for the determination of Total Body Potassium (TBK), based on the detection of the 1.4 MeV gamma rays emitted by the naturally occurring radioisotope (0.01%) ^{40}K .

It consisted of two cylindrical NaI detectors placed above and below the patient and were housed in lead shields (see Figure II). Lying in a supine position on a motorised bed, the patient traversed from head to foot between the detectors. The time for each scan was preset and was related to the height of the patient (typical scan time varied from 12-18 minutes). The

instrument was calibrated using the ^{40}K gamma rays from KCL solution of approximately physiological concentration (51.3 mmoles), in phantoms of varying weight and width. Calibration scans were performed in the same way as those adopted for patients and the observed count rate per gram of K as a function of weight was determined. The overall precision of this technique has been determined to be in the range of 1.6 - 2.8% (Mitra et al 1988). An interlaboratory comparison of TBK has been made in a few individuals. The average of all ratios of values obtained at other centres to that obtained with the Auckland system has been found to be 0.96 +/- 0.06.

Part xii MUSCLE PROTEIN

For the estimation of muscle protein I have utilised a mathematical model developed by Burkinshaw et al, 1979. This model makes it possible to estimate the protein contents of muscle and non-muscle lean tissue from total body nitrogen and potassium. The errors of estimation are too large to allow conclusions to be drawn from a single measurement of an individual but they do permit mean values for groups of subjects to be compared (+/- 0.3 kg SD muscle protein).

$$\text{MP} = (\text{TBK} - R_{\text{NM}} \times \text{TBN}) \times 6.25 / (R_{\text{M}} - R_{\text{NM}}) \text{ (muscle protein)}$$

$$R^{\text{M}} = \text{ratio of potassium to nitrogen in FFD muscle (3.0)}$$

$$R^{\text{NM}} = \text{ratio of potassium to nitrogen in non-muscle (1.33)}$$

A measurement of total body nitrogen alone does not show what fraction of the total protein is in muscle, but the fraction could be estimated if the body content of some other substance, distributed differently between muscle and other tissues was also

measured. Potassium is a suitable substance.

The model:

Underlying observations and assumptions:

The model relies on two observations:

- a) Pure lipid, ie the fat extractable from adipose tissue, contains no potassium or nitrogen.
- b) The ratio of the concentration of potassium to that of nitrogen has different values in muscle and non-muscle lean tissue.

Mean values of potassium concentration range from 76.7 to 107 mmol/kg fresh fat free muscle - the weighted mean value being 91 mmol/kg.

The concentrations of nitrogen in muscle is taken as 28.1 g/kg fresh fat free muscle ("Reference man").

Further assumptions:-

- a) The concentration of potassium and nitrogen in muscle and in non muscle lean tissue are the same in every individual
- b) The concentrations are unchanged when tissue is gained or lost ie. the tissue gained or lost by either compartment has the same composition as that in the rest of the compartment.

Derivation of the equations:

Let K and N be the total amounts of potassium and nitrogen in the body.

Let K_m and N_m be the amounts of the two elements in muscle and K_n , N_n the amounts in non-muscle lean tissue then:-

$$K = K_m + K_n \quad (1)$$

$$N = N_m + N_n \quad (2)$$

$$\text{Let } r = K/N$$

$$r_m = K_m/N_m = 3.03$$

$$r_n = K_n/N_n = 1.33$$

$$rN = r_m N_m + r_n N_n$$

This equation allows us to calculate from measured values of total body potassium and nitrogen, the amount of nitrogen and hence protein in muscle.

Using square brackets to denote the concentration of an element, and M_m denoting the mass of muscle in the body we may write:

$$N_m = [N_m] M_m$$

substituting from equation (3) and transposing:

$$M_m = \frac{K - r_n N}{[N_m] (r_m - r_n)} \quad (4)$$

Similarly if M_n is the mass of the mean non-muscle lean tissue, it can be shown that:

$$N_n = \frac{r_m N - K}{r_m - r_n} \quad (5)$$

and

$$M_n = \frac{r_m N - K}{[N_n] (r_m - r_n)} \quad (6)$$

Substituting into equations (3) to (6) the average values for K in mmol and N in g then:

$$N_m = \frac{K - 1.33N}{1.70} \quad (7)$$

$$N_n = \frac{3.03 - K}{1.7} \quad (8)$$

$$M_m = \frac{K - 1.33 N}{51.0} \quad (9)$$

$$M_n = \frac{3.03N - K}{61.2} \quad (10)$$

LEGENDS FOR FIGURES

Figure I.

Shows the IVNAA facility.

Department of Surgery, University of Auckland,

A typical critically ill patient having determination of TBN

Figure II

Shows the shadow shield, Whole Body Potassium Counter,

Department of Surgery,

University of Auckland

FIGURE I



FIGURE II

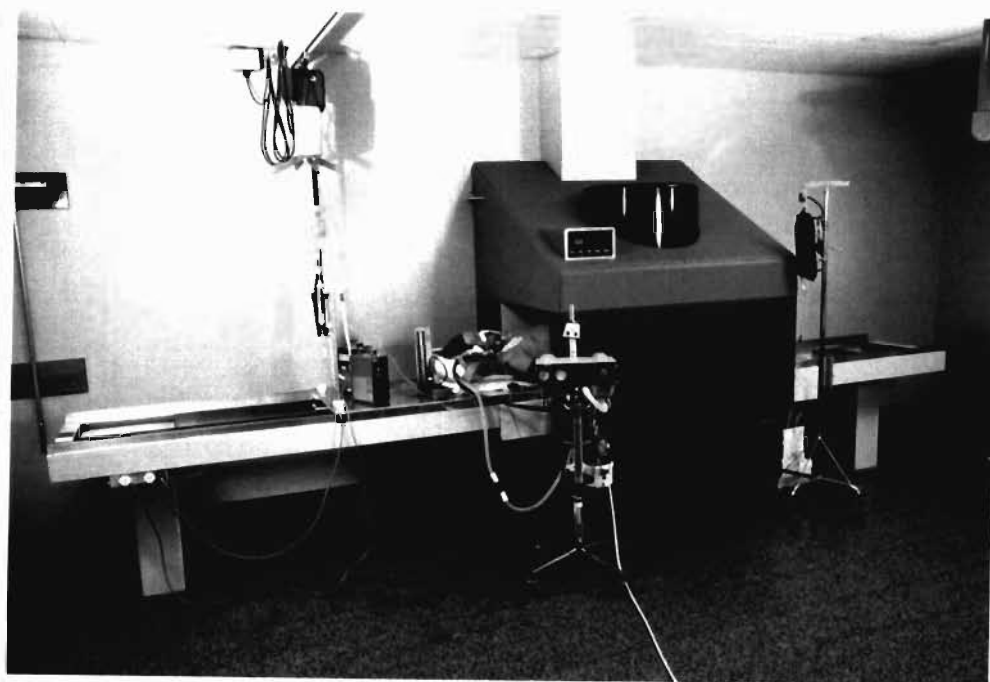

CHAPTER 6 : MEASUREMENT OF RESTING ENERGY EXPENDITURE

It was as early as 1769 when Lavoisier was able to recognise the fundamental nature of oxidation in combustion and respiration. However, it was not until this century with the development of physiological chemistry that the true value of indirect calorimetry was realised through the efforts of Lusk and Benedict (1931).

The measurement of energy expenditure is referred to as calorimetry in which energy is measured as heat. Calorimetry is based on the law of the conservation of energy. This law states that energy can neither be created nor destroyed which means that the energy content of any system such as the human body can be increased or decreased only by the amount of energy that is added or subtracted from the system. Calorimetry as applied to human studies may be divided into two types. Direct calorimetry is the measurement of energy expenditure in the form of heat, all types of energy in the body are converted to heat and then measured. Since energy is utilised in animal tissues by means of chemical reactions, it is possible to evaluate energy utilisation from the measurement of the substances consumed and products formed. In indirect calorimetry, energy expenditure is determined from measuring the amounts of oxygen consumed and carbon dioxide produced. It may be performed in either of two ways. In the open-circuit method, the subject is permitted to breath air from the environment, while his expired air is collected for volumetric measurement. The gas volume is then corrected for standard

conditions and is analysed for its oxygen and carbon dioxide content with a subsequent calculation of O₂ consumption and CO₂ production. In the closed-circuit system the subject often breaths from a reservoir containing pure oxygen and as the gas is expired by the subject, carbon dioxide is constantly removed by some material such as soda lime. The decrease in the gas volume in this closed system is related to the rate of the oxygen consumption from which the metabolic rate is then calculated.

Indirect calorimetry in this thesis was performed using a modification of the ventilated hood technique originally described by Kappagoda et al 1974.

Part 1 DESCRIPTION OF THE INDIRECT CALORIMETER APPARATUS

Figure I shows an exploded diagrammatic view of the indirect calorimeter. The components of the system are labelled in the figure A to J

A is the rigid perspex head canopy which has an oversized aperture to facilitate passage of the subject's head. Attached to the aperture is a neck collar made of an impervious woven nylon material with an elasticated border to provide a snug fit around the subject's neck.

B is the room air intake portal. C is the mixing chamber with a capacity of about 50 litres. It ensures good mixing of the expiratory gases with the air stream.

The temperature of the gas stream is measured with a thermometer mounted inside the mixing chamber and the flow rate measured by a gas rotometer, D. Beyond the measurement of flow, portals, E, allow continuous sampling of the air stream for the analysis of

oxygen and carbon dioxide.

F is a Servomex paramagnetic oxygen analyser OA.540 (Sybron/Taylor Instrument Analytics Ltd, Crowborough, Sussex, England) with a drying chamber containing silica gel to rid the sample gas of water vapour.

G is an ADC infra-red carbon dioxide analyser, type SSI (The Analytic Development Co Ltd, Pinder Road, Hoddeson, Herts, England EN11 0AQ).

F and G draw off sample gas at a rate of 0.5 and 1.5 litres per minute respectively. The linearised analogue signals from the analysers are conveyed to H, a Yokogawa two channel flatbed pen chart recorder model 3021 (Yokogawa Electrical Works, 9-32 Nakacho 2-chrome, Musashino-shi, Tokyo 180, Japan).

I is a variable torque rotatory gas pump able to be set to the appropriate flow rate by a transformer in series.

The calibration gas cylinder, J, contains a nominal gas mixture of 20% oxygen and 1% carbon dioxide with the balance composed of nitrogen. This prescription gas was previously analysed by the Lloyd-Haldane technique utilising the Lloyd-Haldane apparatus to give an accuracy of +/- 0.01%.

The apparatus was located in a dedicated, quiet room with dimmable lighting at the end of a surgical ward suite. The room was air conditioned the air being kept within a temperature range of 21 to 25 degrees centigrade and at about 50% water vapour saturation. The barometric pressure recording was obtained by telephone link with the city weather authority and adjusted by a standard increment appropriate to the elevation difference.

Part ii STANDARD TECHNIQUE

At the beginning of each recording day, the silica gel container in the oxygen analyser sample line was recharged with fresh dry ingredient. Both analysers were switched on, as was the pump which generated the flow of air through the system. The pen-chart recorder was turned on. A minimum of 15 minutes warming up time was necessary to prevent baseline drift in the readings of both oxygen and carbon dioxide concentrations and air stream flow. The rotometer reading was adjusted to the standard flow rate (60 litres per minute) by adjusting the transformer rheostat of the pump. The gas analysers were calibrated on room air as the low calibration standard and from the prescription gas as the high standard. The patient was wheeled into the study room before which he must have been lying quietly on his bed for 30 minutes. The initial measurement was performed after an overnight fast, before any nutritional support had started. This was the Resting Metabolic Expenditure (RME). Subsequent measurement during the period of IVN included the dietary induced thermogenesis and was termed the Resting Energy Expenditure (REE). An explanation of the test and reassurance about the adequacy of the hood ventilation (ten times the minute volume, 60l/min versus 6l/min) was necessary for the initial test. The head canopy was passed over his head and the elasticated collar adjusted for comfort. The lights were dimmed. The typical test lasted for 30 minutes, the first ten minutes of which was the time taken for stabilisation of the trace recordings at new plateau positions.

A typical trace recording is shown in figure II. The higher

plateau in each case represent the recording of the calibration gas as the high standard and the lower plateau the actual patient record. The baselines are the readings for room air and constitute the low standard. It can be seen that the expired concentrations of oxygen and carbon dioxide can be determined simply by proportion. The barometric pressure and temperature readings were recorded. Frequent checks of the rotometer were made to ensure standard flow conditions. After at least 20 minutes of steady-state recording of oxygen and carbon dioxide concentrations, the head canopy was removed. It took about 5 minutes for return of the traces to the baseline positions on the pen-chart recorder.

The calculation of VO_2 , VCO_2 and REE:

Figure III shows a worksheet for the calculation of oxygen consumption (VO_2); carbon dioxide production (VCO_2); respiratory quotient (RQ), and energy expenditure, either resting or metabolic expenditure (RME) or resting energy expenditure (REE). The steps are as follows:-

- a) Measure and record the temperature of the air stream with the thermometer in the mixing chamber.
- b) Record the barometric pressure obtained from the city weather office. Adjust for elevation difference.
- c) Using (a) and (b) derive and record the STP factor from Standard Temperature and Pressure tables (Geigy 1975)
- d) Calculate the adjusted air stream flow rate by multiplying the measured flow (i.e. 60 L/min by the STP factor.)

- e) Record the concentrations of oxygen and carbon dioxide in the calibration gas mixture previously determined by the Lloyd-Haldane method of volumetric gas analysis.
- f) Measure and record the span of the deflection on the pen chart recorder of the oxygen and carbon dioxide traces during calibration.
- g) Measure and record the span of the deflection plateau of the oxygen and carbon dioxide traces during the subject reading.
- H) Derive the change in oxygen and carbon dioxide concentrations of the subject reading by multiplying the ratio of the subject and calibration spans by the difference of the gas concentrations between the calibration gas mixture and room air.
- i) Multiply these results by the adjusted flow rate derived in (d) to obtain the VO_2 and VCO_2 in L/min.
- j) Multiply VO_2 and VCO_2 by a factor of 1.44 to change the units to L/day.
- k) Express VCO_2 over VO_2 as a ratio to derive the RQ.
- l) Multiply the VO_2 by a caloric conversion factor derived from tables utilising the RQ value (Geigy 1975) to obtain the RME/REE in units of Kcal/day.

Metabolic Stress

The measured values of RME were compared with the values predicted from equations that relate resting metabolic expenditure to the fat free mass (FFM, the sum of water, protein, minerals and glycogen in kg) This regression equation was derived from 136

normal subjects who underwent direct measurement of RME and FFM.

$RME \text{ (Kcals/day)} = 13.58 \text{ FFM} + 554 \text{ (males and females)}$

In this way it is possible to devise a "stress index" defined as the ratio of the measured RME to the predicted RME. If the stress index was greater than 2 SD's above the mean for the normals (1.00 +/- 0.18) ie., > 1.18 or > 118% of predicted normal, then the patients were deemed to be metabolically stressed.

Part iii ASSUMPTIONS AND ERRORS

Respiratory gases must be collected, stored and analysed. Each step presents possibilities for errors from loss, dilution or addition of gases. The collection of these gases may not be complete through leaks which may themselves cause different types of errors. Another source of error would be initial calibration against gas mixtures of known composition. Even the most prestigious of companies may provide gas mixtures that are far from their stated composition.

The open-circuit method of indirect calorimetry assumes that all gas exchange occurs across the lungs. Also the respiratory gas equations treat O_2 and CO_2 as ideal gases. Johnson et al 1980, has pointed out that this is correct for O_2 and for N_2 but is only partially true for CO_2 thus introducing a small error. A more important error is related to the water vapour where the expired air is assumed to be saturated and complete dryness is required for the use of the gas equations, neither of these conditions may be totally correct.

Despite these assumptions and obvious sources for error, indirect calorimetry still remains a very useful clinical tool especially

in the context of the patient who has sustained major weight loss or is suffering from a catabolic stimulus much as the patients studied in this thesis.

LEGENDS FOR FIGURES

Figure I.

Shows an exploded diagram of the Indirect Calorimeter.

Figure II

Indirect Calorimetry pen-chart trace recording.

A and B are the baseline readings of the concentrations in room air of O_2 and CO_2 respectively.

C and D are the plateau readings of the concentrations in the calibration gas mixture of O_2 and CO_2 respectively.

E and F are the plateau readings of the concentrations in the effluent gas mixture from the head canopy of O_2 and CO_2 respectively.

Calibration spans in mm for O_2 and CO_2 (S_c and S'_c) are the perpendicular distances between A - E and B - F respectively.

Figure III

Worksheet for the calculation of VO_2 , VCO_2 , REE and RQ.

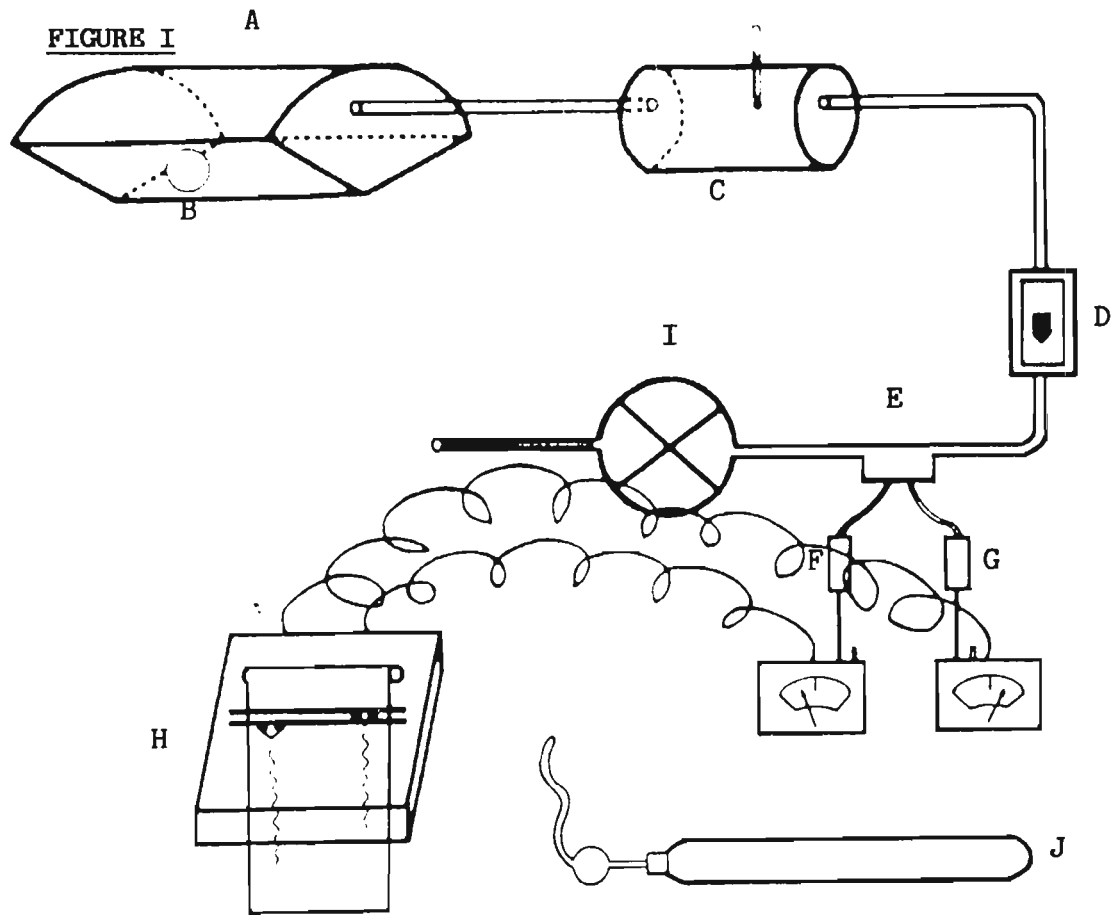

FIGURE II

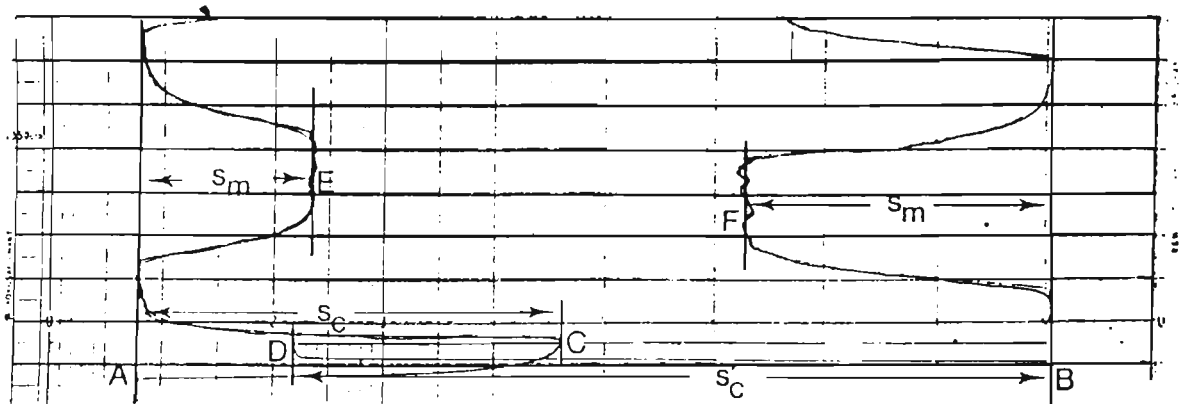

FIGURE III

DATA ENTRY:

Barometric pressure
 Temperature
 SIPD factor (from tables)
 Flow rate
 O₂ calibration span
 O₂ measurement span
 FO₂ calibration gas
 CO₂ calibration span
 CO₂ measurement span
 FCO₂ calibration gas

P _B	mmHg
T	degrees C
SIPD	
f	l/min
s _c	mm
s _m	mm ²
F _c O ₂	
s' _c	mm
s' _m	mm
F _c CO ₂	

CALCULATIONS:

- (1) Adjusted flow rate $F' = f \times \text{SIPD}$
- (2) $\text{VO}_2 = f' \times 10^{-3} \times (0.2094 - F_c \text{O}_2) \times s_m / s_c$
- (3) $\text{VCO}_2 = f' \times 10^{-3} \times (F_c \text{CO}_2 - 0.0003) \times s'_m / s'_c$
- (4) $\text{RQ} = \text{VCO}_2 / \text{VO}_2$
- (5) Caloric factor, $C_f = 4.677 + (\text{RQ} - 0.7) / 0.7 \times 0.863$
- (6) $\text{REE} = C_f \times \text{VO}_2 \times 1.44$

	L/min
	ml/min
	ml/min
	Kcal/ml
	L/day

CHAPTER 7 : PLASMA PROTEINS

Plasma albumin, transferrin and pre-albumin levels were determined from venous blood drawn immediately before and after the 7 and 14 days study period. Plasma transferrin and pre-albumin were measured by laser nephelometry using appropriate anti-sera (transferrin, Herhingwerke, Prealbumin DAKO) see below. Plasma albumin was assayed on a SMA auto analyser by the bromocresol green method. Normal ranges for our laboratory are 35-50 g/l for albumin, 176-340 mg/100 ml for transferrin and 22.0-38.1 mg/100ml for pre-albumin (for details of analysis see below).

Part i TRANSFERRIN

1. Dilution of Samples (all in duplicate)
 - a. Standards N-std-protein-serum (or LN-std-protein-serum)
 - 1/60 10 ul of std + 590 ul of saline
 - 1/80 10 ul of std + 790 ul of saline
 - 1/120 300ul of the 1/60 std + 300 ul saline
 - 1/160 300ul of the 1/80 std + 300 ul saline
 - 1/320 300ul of the 1/160 std + 300 ul saline
 - 1/640 300ul of the 1/320 std + 300 ul saline
 - b. Controls (i) std-human-serum
 - (ii) Quantitrol (note reconstituted vials only stable for 1 month).
 - dilute 1/151 (10 ul + 1.5 ul saline)
 - c. Patient samples (pretreated with lipoclean)
 - dilute 1/151 (10 ul + 1.5 ml saline)

Low results repeat at 1/101 dilution (10 ul + 1 ml saline)
High results repeat at 1/201 dilution (10 ul + 2 ml saline)

2. Dilution of antisera

Dilute 1/40 Need 0.2 ml per tube

i.e. 90 assays = 0.46 ml antisera + 17.54 ml saline

After dilution antisera filtered through 0.22 um millipore filter (allow for a little loss in filtering).

3. Reaction

- a. Into numbered cuvettes add 100 ul of each sample
- b. Add 200 ul antisera mix, immediately take blank reading
- c. Leave covered 1 hr at room temperature for 2 hours.
- d. Mix, take second reading.

Part ii PREALBUMIN

1. Dilution of samples (all in duplicate)

a. Standards (duplicate) std - human - serum

1/15 30 ul of std + 420 ul saline

1/20 30 ul of std + 570 ul saline

1/30 200 ul of 1/15 std + 200 ul saline

1/60 200 ul of 1/30 std + 200 ul saline

1/120 200 ul of 1.60 std + 200 ul saline

b. Controls (i) Ln - std - protein serum

(ii) Normal

Dilute 1/31 (30 ul + 900 ul saline)

c. Patient samples (Pretreated with lipoclean)

Dilute 1/31 (30 ul + 900 ul saline)

Low results repeat at 1/11 dilution 30 ul + 300 ul

High results repeat at 1/41 dilution 30 ul + 1200 ul

(Computer will tell you if the result is out of the range of the std curve).

2. Dilution of antisera

Dilute 1/8 need 0.2 ml per tube

i.e. 52 assays = 1.3 ml antisera + 9.1 ml saline

80 assays = 2 ml antisera + 14 ml saline

After dilution antisera filtered through 0.22 um millipore filter

NOTE: lose a little in filtering so make 0.1 ml more than needed.

3. Reaction

- a. into numbered cuvettes add 100 ul of each sample
- b. add 200 ul antisera, mix, immediately take blank reading
- c. Leave covered at room temperature
- d. Mix, take second reading.

CHAPTER 8 : URINE AND ILEOSTOMY CHEMISTRY

Urine Chemistry

All patients and controls underwent 2 consecutive 24 hour collections to allow an average 24 hour analysis to be performed. The first bottle containing acid (calcium and oxalate) and the second bottle thymol (uric acid). Analysis commenced immediately the collection was complete.

Sodium and Potassium Content

The content of sodium and potassium was determined using an automatic analyser (BM/Hitachi System 704).

Calcium Content

The content of calcium was determined using an automatic analyser (MB/Hitachi System 704) Reference range 2.5-7.5 mmol/day (Auckland Hospital).

Uric Acid Estimation

The method for uric acid estimation utilised the uricase reaction (Town et al 1985) Reagents.

1. Stock borate buffer, 0.5 mole/L, pH about 9.5
Dissolve 31g boric acid, 10g sodium hydroxide, and 1 g lithium carbonate in water and dilute to 1L
2. Working borate buffer.
Dilute to stock solution 1:10 with water.
3. Stock colour reagent
Dissolve 0.3g copper sulfate and 0.6g neocuproine in water in a 1 dL volumetric flask. Add 1 drop of

1 mole/L HCL and then dilute to 1 dL with water and mix well.

4. Working colour reagent

Dilute the stock reagent 1:10 with water

5. Enzyme reagent.

Catalase solution in glycerol (Boehringer Mannheim Biochemicals, Indianapolis).

Uricase solution 2mg/ml (Boehringer Mannheim Biochemicals, Indianapolis)

As needed, mix together 4 volumes of the uricase solution, 1 volume of the catalase solution and 3 volumes of water. Prepare only the amount needed for the days work and store mixture in the refrigerator when not used.

6. Standards. The standards are the same in the previous method.

Procedure

For each sample add 3.0 ml of borate working buffer to each of the tubes, then add 100 uL of sample to each tube. To one of the pair add 20 uL of the enzyme solution and mix. Set up similar pairs using 100 uL of working standard and 100 uL of water. Allow all tubes to stand at room temperature for 10 minutes, then add 1 ml of the colour reagent to each tube and mix. Allow tubes to stand

for 5 minutes. Read all the tubes without enzyme against blank without enzyme and all tubes containing enzyme against the blank with enzyme at 454 NM. Subtract the absorbance of tube containing sample plus enzyme from the absorbance of tube containing sample without enzyme. Do the same for the standard.

Calculation:

$$\frac{A(-e) - A(+e) \text{ of sample}}{A(-e) - A(+e) \text{ of standard}} \times \text{Conc of standard} = \text{Conc of sample}$$

Where $A(-e)$ of sample = absorbance of sample without enzyme, $A(+e)$ of sample = absorbance of sample with enzyme, $A(-e)$ of standard = absorbance of standard without enzyme and $A(+e)$ of standard = absorbance of standard with enzyme.

Normal Values

The amount of uric acid excreted in the urine depends in part on the diet. With an ordinary diet the normal amount excreted may vary between 2.5-5 mmol/day (Normal range Auckland Hospital)

Oxalate

Urinary oxalate was measured using an enzymatic method (Commercial kit (Sigma)) (Parkinson et al 1987)

Principle

Oxalate is oxidised to hydrogen peroxide and carbon dioxide by oxalate oxidase. The hydrogen peroxide reacts with 3-methyl-2-

benzothiozolinone hydrozone (MBTH)) and 3 - (dimethylamino) Benzoic acid (DMAB) in the presence of peroxidase to yield an indamine dye which has a maximum absorbance at 590 nm

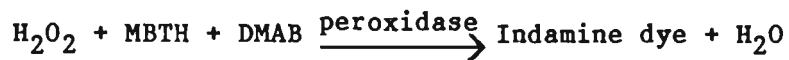
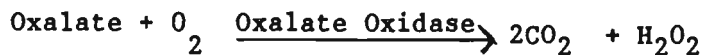

Reagents

1. Oxalate reagent A. Stock no: 590-10 contains;
3 - (dimethylamino) benzoic acid 32 umol (DMAB)
Peroxidase (EC 1.11.1.7 Horseradish) approx 50 u
Oxalate oxidase
(EC 1.2.3.4. Barley)
Also contains buffer salts and stabilizers. Store in the refrigerator.
Reconstitute with oxalate reagent B. 9.0 ml
Invert gently to dissolve the contents - do not shake.
Reconstituted reagent is stable for at least 4 weeks when stored in the refrigerator, longer in the freezer.
2. Oxalate reagent B stock No; 590-1 contains;
3- Methyl -2 - Benzothiozolinone 0.2 mmol/L
MBTH
buffer, preservative and stabilizers.
Store in the refrigerator.
3. Oxalate standard stock no; 590-50
Contains;
Oxalic acid

Preservative added.

Store in the refrigerator.

4. Oxalate extraction vial stock no: 590-4

5. Sodium hydroxide 0.2 M

Method

Extraction;

1. Add 1.0 ml acidified urine, standard or control to appropriately labelled extraction vials.
Cap tightly and mix on the shaker for 5 minutes.
2. Allow the absorbent to settle.
Aspirate and discard the liquid
- 3, Add 2.0 ml of water to each vial, cap, shake for 2-3 minutes and allow the absorbent to settle.
Aspirate and discard the water.
4. Add 1.0 ml 0.2 M sodium hydroxide to each vial, cap tightly and mix for 5 minutes.
Allow the absorbent to settle.
Using a pipette transfer the extracts to suitably labelled tubes.

Assay

1. Reconstitute 1 vial oxalate reagent A with 9.0 ml of oxalate reagent B. Invert gently to dissolve.

2. Measure the absorbances of standard controls, and extracted samples with an autoanalyser (Cobas Fara)

The 24 hour urinary oxalate reference range for 23 clinically healthy adult males and females on an unrestricted diet using the method described were:

Males 0.08 - 0.49 mmol/24 hours

Females 0.04 - 0.34 mmol/24 hours

Glycosaminoglycans Estimation

Urinary glycosaminoglycans (GAGS) was determined using Alcian blue 8GX - The basic method is described in detail in the paper (Whiteman 1973). Standard (GAGS) solution (20 ul containing 1-10ug of glycosaminoglycan) of 50 ul of centrifuged urine for patients and controls were mixed with 1 ml of a reagent containing 0.05% Alcian Blue 8GX and 50 mmol-MgCl₂ in 50 mmol-sodium acetate adjusted to pH 5.8 with acetic acid.

After equilibration for 2 hours at room temperature, the GAGS - Alcian Blue complex was separated by centrifugation at 2000g for 15 minutes. After the precipitate had been washed with ethanol (2ml) it was dissolved with 1 ml of 40% Manoxol IB solution. The E₆₂₀ of the resulting clear blue solution was measured in 1cm microcuvettes using a SP500 spectrophotometer. The glycosaminoglycan contents of the urine samples were determined by reference to a calibration curve constructed by using chondroitin-4-sulphate as standard. The normal range for urinary GAGS has been

previously quoted as 14.9 +/- 0.6 mean +/- SEM mg/L (Bambach et al 1981).

Ileostomy Chemistry

To estimate the sodium and potassium content of ileostomy fluid, a sub-sample of stool was weighed, homogenised and centrifuged and the supernatant was analysed by flame photometry (Conning flame photometer)

CHAPTER 9 : WOUND HEALING RESPONSE

The method used to measure the wound healing response was that of Goodson and Hunt (1982). This included the subcutaneous implantation of thin walled Gore-tex tubes (1mm diameter) (Gore and associates) along the line of a standardised needle track wound on the lateral aspect of the upper arm. The implants were inserted on day 0, the day prior to commencing IVN and day 7 following one week of IVN. The implants remained in situ for seven days before extraction. An attempt was made to make two wounds of similar lengths (about 5-7 cm in length). The wound healing response was assessed from the amount of hydroxyproline in the implants at the end of the implantation period.

For method of insertion and analysis see below:

We have had previous experience with this technique in our department (Haydock et al 1987) and the limitations as to its use have been discussed in detail elsewhere (Haydock et al 1987). Even for a single implant there is the difficulty in being quite sure what the changes mean in biological terms. It maybe incorrect to class this response as solely a wound healing response, rather the accumulation of collagen in these tubes depends on a complex cascade of biological events. These events begin with acute inflammation and cellular invasion, macrophage stimulation, fibroplasia and then the final step of collagen production. This technique is really measuring more than just the wound healing response - it detects a deficiency in acute inflammation and

cellular invasion and hence has widespread implications for host defence.

Gore-Tex Insertion And Analysis.

1. 5 cm lengths of Gore-Tex were heat sealed to 15 cm lengths of prolene 0 (3.5 metric) suture material. (enough heat to melt the polypropylene but not the teflon. about 220°C). They were then packaged and steam sterilised.
2. Following two very small intradermal blebs of local anaesthetic at the entrance and exit points of the wounding needle the Gore-Tex was placed in the upper outer aspect of the arm by inserting a 3 inch 14 gauge angiocath subdermally but with the tip projecting from the skin. The needle was withdrawn and the Gore-Tex inserted into the angiocath teflon liner hub, prolene end first. The Gore-Tex tube was pulled through until midway along the lumen of the angiocath and held while the angiocath was removed. The withdrawing of the angiocath pulled the Gore-Tex straight and ensured an unkinked reproducible placement. The prolene filament was trimmed to within 10 mm of the skin and a dressing was applied.
3. After 7 days the Gore-Tex was pulled out by gentle tension on the prolene.
4. The prolene was cut off and the Gore-Tex washed in distilled water in a shaking water bath at 37°C for 2 hours.
5. The entire 5 cm of Gore-Tex was hydrolysed in 6M hydrochloric

acid for 18 hours at 116^oc. The porous nature of the Gore-Tex allowed good penetration of the acid and released into solution the amino acids. The hydrolysate was subsampled and analysed by a standard autoanalyser method for hydroxyproline.

6. The Gore-Tex was then boiled in concentrated nitric acid for 5 hours. This oxidised any residual organic material and decomposed the stump of prolene filament. Provided the acid did not boil away there was no damage to the teflon tube as shown by scanning electron micrographs. After the acid wash the Gore-Tex is boiled in distilled water and oven dried overnight at 50^oc.
7. The Gore-Tex was "massaged" to restore the texture of the expanded teflon by pulling it through the fingers a few times, re-attached to new prolene and resterilised.
8. Note the hydroxyproline was expressed as nmol/mg Gore-Tex because the Gore-Tex varied in wall thickness within and between batches and if length was used errors may have occurred because the volume of Gore-Tex available for cell infiltration per centimetre would vary.

CHAPTER 10: SKELETAL MUSCLE FUNCTION

The tests of skeletal muscle function used in this thesis have been extensively validated for nutritional assessment in recent years.

Maximal Voluntary Grip Strength has been previously shown not only to relate to the total body protein stores (Windsor et al 1988b) but also to be a sensitive index of post-operative risk (Klidjian AM et al 1977), (Windsor et al 1988a).

Involuntary skeletal muscle function as defined by the contraction and relaxation characteristics of the adductor pollicis muscle using an apparatus similar to that described by Edwards et al 1977, Jeejeebhoy 1986, Lopes et al 1982, Russel et al 1983 a,b,c,; Chan et al 1986 and has proved to be a sensitive index of both malnutrition and also nutritional repletion.

It has been already shown (Lopes et al 1982) that the rate of skeletal muscle relaxation in malnourished patients was up to 25% lower than normal subjects. With this slower rate of relaxation there is a shift in the force frequency profile of the muscle ie., fusion of muscle twitches and tetany occurring at lower stimulating frequencies. This leads to an increase in the Force:Frequency ratios : F10:F20, F10:F50.

These changes relate to intrinsic properties of the muscle itself.

Part i MAXIMAL VOLUNTARY GRIP STRENGTH

Was measured in the dominant hand using a vigorimeter. The seated patient was instructed to squeeze the vigorimeter quickly and

maximally to give a reading on the meter in Kgs. Three readings were made with 15 seconds intervals and the best of the three attempts were recorded as the maximal voluntary grip strength. Half the patients in the first clinical study had grip strengths measured using an earlier vigorimeter (Ortopedia, West Germany) with a 50 mm bulb. The coefficient of variation for this method was 5.45% and the normal range for men was 100-180 KPa and for women 55-100 KPa. The vigorimeter itself was calibrated regularly and had a coefficient of variation of 2.4%.

In the majority of the clinical studies a new isokinetic dynamometer was employed reading in Kgs. This instrument was designed and built with the assistance of the Biomedical Workshops, University of Auckland School of Medicine. The deflection following maximal grip was so small that it was truly isometric. The bar being depressed by the hand grip (See Fig I, was connected to a strain gauge (Kyowa KFC-2-C1-16). The strain gauge was calibrated and found to be linear $r=0.98$ (CV=1.5% over the range of 5 to 60 Kg.

With regard to the precision of this instrument the coefficient of variation for this instrument was 3.9% and the normal range for men was 31-59Kg and for women 22-40Kg.

Maximal voluntary grip strength was measured in 128 normal subjects (70 with the bulb and 58 with the new vigorimeter). Grip strength was regressed against the variables age in years (A), height in cm (H) and sex (M=1, F=0), yielding the following regression equations;

$$GS = - 36.59 + 25.1 (\text{sex}) - 0.48A + 0.72H$$

(bulb, KPa)

$$GS = - 45.92 + 12.0 (\text{sex}) - 0.12A + 0.49H$$

(Kg)

Thus by relating the respective measured value for GS to the predicted value from the above regression equation it was therefore possible to derive a Grip Strength Index (GI) for the patient. The mean GI for normal volunteers with bulb was 1.00 +/- 0.18 (SD) and 1.00 +/- 0.16SD for the standard vigorimeter i.e. if the patients GI were < 0.68 (or 2 SD's below the means of the normal population) then they were considered to have impaired grip strengths.

Part ii INVOLUNTARY SKELETAL MUSCLE FUNCTION

Using an apparatus based on the principles of Edwards et al 1977, developed and constructed with the assistance of the Biomedical Engineering Workshops, University of Auckland School of Medicine measurements of the involuntary force generated by the abductor pollicis muscle were obtained by selective stimulation of the ulnar nerve at the wrist with supra-maximal voltages (80-120 volts). A square wave pulse of 50 microseconds durations at frequencies increasing from 10 HZ to 50 HZ for one to two seconds at a time was used. In this manner the F10:F20 and F10:F50 force ratios were obtained, together with the maximal force F50. These tests were preceded by warming the hand to 40°C with an electric lamp held at a fixed distance from the hand. The effects of post tetanic potentiation were standardised by a fixed order of testing. All measurements were performed in duplicate.

Equipment (see Figure II)

The subject's dominant hand and lower arm was supported in the apparatus. A sling was placed around the interphalangeal joint of the thumb and connected to the force transducer (Model B5102-50 IOPI, Serial 7117, Transducer Inc., Winter California). This force transducer was tested for linearity over the range of 100 grams to 10 kg at 3 monthly intervals ($r=1$, $CV=3.9\%$)

Ulnar nerve stimulation

Was performed with a saline soaked gauze covered electrode held to the subjects wrist by the examiner at a point previously found to produce a maximal stimulus. This method was found superior to a previous method where the stimulating electrode was initially

secured to the hand rig itself, owing to slight displacement of the electrode following unavoidable stimulation of the wrist flexors.

The square pulse stimulus was provided by a Grass Physiological stimulator (Model 544D, Serial 4M03V0, Quincy Mass, USA). The frequency output of the stimulator had a precision of 1%.

Force measurement

The force transducer was connected to a strain gauge amplifier and to a multi channel pen recorder. Unfortunately during the period of my research I was not able to acquire a pen recorder sufficiently fast to record the maximal relaxation rate with acceptable precision. The force transducer was calibrated immediately prior to testing by applying a number of loads (0-10kg) to the sling.

Normal values and precision

The normal values for F10:F20 and F10:F50 were 48 +/- 4% and 33 +/- 3% (\bar{x} +/- SEM) respectively with no difference between the sexes. The mean value of F50 was 5.6 +/- 0.5Kg for males and 4.3 +/- 0.4 Kg for females. The coefficient of variation for these 3 parameters of involuntary muscle function were 17.6%, 14% and 10% respectively. Clearly this level of precision was inadequate for a single individual but adequate to draw conclusions from grouped data.

LEGENDS FOR FIGURES

Figure I

A patient having maximal voluntary grip strength measured.

Figure II

A patient having Involuntary Skeletal Muscle Function assessed.

FIGURE I



FIGURE II



CHAPTER 11 : RESPIRATORY MUSCLE FUNCTION

Many tests have been used previously to assess respiratory muscle function. Most of these have been however in the field of exercise physiology rather than in the clinical situation.

The tests of respiratory muscle function used in this thesis, have already been validated extensively (Arora et al 1982) and are particularly appropriate for use at the bedside or in conjunction with other measurements used in this thesis to assess PEM.

Part i RESPIRATORY MUSCLE STRENGTH

Respiratory muscle strength (RMS) was measured as the mouth pressure with a Validyne bidifferential pressure transducer (model MP45 Validyne Engineering Corp , Northridge CA 91324, Range +/- 50 cmH₂O) during Maximal Static Inspiration (MIP) at functional residual lung capacity and during Maximal Static Expiration (MEP) at total lung capacity (Arora et al 1982 ;Cook et al 1964). The value of RMS was the average value of MIP and MEP expressed in cms of water.

MIP - during the test, the patient was sitting up on the edge of the bed or in a chair as upright as possible. The patient was given maximal encouragement, and the procedure was carefully explained. It was important to get a good mouthseal with a plastic scuba type mouthpiece (Hewlett Packard). A valve unit was designed which was incorporated into the mouthpiece unit to allow for the different measurements (MIP,MEP,and MVV) without the need to break the air seal at the lips. An intentional air leak (using a 1mm diameter screw valve) was built into the mouthpiece unit for the

measurement of MEP. The air leak ensured that the glottis remained open, which prevented falsely high values due to activity of the cheek muscles (Black et al 1969, Kelly et al 1982). The patient was observed while breathing through the open valve. Then the patient was asked to expire all air (Residual Volume), the valve was closed and the patient was asked to breath in as deeply as possible (maximal suck). This pressure was recorded by the Validyne on a multichannel pen recorder. This measurement was repeated twice and the best value was recorded. A time period (minimum of 2 minutes) between each measurement was insisted to allow a return to normal normal respiratory rate between each reading. The Validyne had been previously calibrated by applying a series of normal pressures to the Validyne documenting them on a Dekamet Accoson Mercury sphygmomanometer column simultaneously through a Y connection. Calibration of the pressure transducer was performed monthly in our laboratory confirming constant linearity ($r=0.99$) From a previous large study of 60 normal volunteers (Normal Study 1986, Unpublished Data) the normal values of MIP were: 117 ± 44 (SD) cmH_2O males and 75 ± 29 (SD) cmH_2O females.

The coefficient of variation for this measurement from 20 repeated measurements was 2.0%.

MEP - In a similar manner the patient was asked to breath in as much air as possible, (Total Lung Capacity) with valve open, the valve was then closed and the patient blew out (as hard as possible), ensuring a good mouthseal with the air leak valve open.. The measurement was repeated twice ensuring an adequate

rest in between. The normal values of MEP in our laboratory were 124+/- 42 (SD) cmH₂O males and 75 +/- 26 (SD) cmH₂O females.

The coefficient of variation for MEP was 12.7%. The combined measurement of RMS had a coefficient of variation of 7.7%. As an index of repeatability over time the correlation coefficient of 53 paired normal measurements measured 1 week apart was 0.90 (P=0.0001)

Part ii MAXIMAL VOLUNTARY VENTILATION

Maximal Voluntary Ventilation (MVV) can be used, and has been used previously, as a measure of respiratory muscle endurance (Arora et al 1982). This is measured at a fixed respiratory rate and usually over 60 seconds - Maximal minute ventilation (MMV) or even maximal sustainable ventilation (MSV) which is the level of ventilation sustainable over 15 minutes (Rochester et al 1984a). However, Aldrich et al 1982 have shown that MSV correlates with respiratory muscle endurance and that a 12 second MVV correlates well with the MSV. Thus I have used the MVV over 15 seconds as my index of respiratory muscle endurance.

Maximal voluntary ventilation or endurance of the respiratory muscles was measured at a fixed frequency (Arora et al 1982).

The MVV was measured (as cumulative inspiratory volume in litres per minute) using a digital pneumotachygraph (Hewlett Packard, Model 47303A, Vertex Series) which calculated air volume from air flow over the 15 second period. A size 3(47303-60050) pneumotach (or linearised Fleisch type flow transducer) was used. This had an internal diameter of 45 mm and a maximal flow rate of 12.5 litres per second. The analog flow accuracy was +/- 5%. The pneumotach was fitted to the mouthpiece unit used for the measurement of MIP and MEP. To measure MVV the valve was left open and the air leak and tubing to the pressure transducer were both closed. Calibration of the flow transducer was performed at six monthly intervals confirming constant linearity ($r=0.99$). After checking the Pneumotach settings and prewarming (39°C) - the patient was instructed to breath in and out as hard and deeply as possible.

The rate of breathing was standardised by having the patient breath in, in sequence with flashing green light (a visual metronome) The inspiratory volume was recorded on the digital display for a full 15 seconds. This value was multiplied by 4 for inspiratory volume per minute then by 2 to gain total volume moved in full respiratory cycle. Normal values for MVV, in our laboratory were 142 +/- 26 SD L/minute males and 81 +/- 18 SD L/minute females

The coefficient of variation for this index of respiratory muscle endurance was 4.3%. The correlation coefficient of 53 paired results 1 week apart was 0.80 (P=0.0001)

Part iii SPIROMETRIC TESTS

Forced expiratory volume in one second (FEV1) Vital Capacity (VC) and Peaked Expiratory Flow Rate (PEFR) were determined by standard spirometric techniques (Macklem 1986, Diamant et al 1967). Each parameter was measured in triplicate, with the highest value taken. FEV1 and VC were measured using a portable vitalograph spirometer. Calibration of the spirometer was performed with the 1 and 3 litre syringes, confirming linearity ($r=1$).

PEFR was measured using a Wrights flow meter. This was calibrated by the Physiology Department at the University of Auckland Medical School. The normal values for these 3 spirometric measurements in our laboratory were 3788 +/- 923 SD litres, 4896 +/- 926 SD litres and 578 +/- 87 SD L/min for males respectively and 2756 +/- 621 SD litres, 3426 +/- 699 SD litres and 450 +/- 55 SD L/min for females respectively.

The coefficient of variation for these 3 spirometric measurements were 2.7% 2.4% and 3% respectively. Again as a test of repeatability the correlation coefficients of 53 paired results performed 1 week apart with these 3 instruments were 0.99, 0.98 and 0.96 respectively.

LEGEND FOR FIGURE

Figure I

A patient undergoing respiratory muscle function assessment.

FIGURE I



CHAPTER 12 : PSYCHOLOGICAL FUNCTION

Assessment of Psychological Function

The first psychological symptom self-report scale was the result of Robert Woodworth's insight into the potential for each man "to interview himself" (Woodworth 1918, See reference Derogatis L.R. 1974). Self-report possesses the singular advantage of reflecting information for the "experiencing self", whereas the clinical observer is limited to reporting "apparent versions of the patients experience based on his behaviour and verbal report".

The Self-report Symptom Inventory has become one of the most frequent means of operationally defining "normality" versus "abnormality" and has been shown to have very high levels of incremental validity (Sines 1959, see reference Derogatis L.R. 1974).

The Clinical Psychometric Research Unit became involved with the self-report measurement of psychological symptoms in the form of the Hopkins Symptom Checklist (HSCL) (Derogatis 1974). In spite of the reliability and validity of this check list the main problem was that it had been developed totally for a research instrument and had never been developed for use with the individual patient. Hence the HSCL was superceeded by the SCL-90-R.

The SCL-90-R is a 90 item self reporting symptom inventory designed to primarily reflect the psychological symptom patterns of psychiatric and medical patients.

I have used an abbreviated version of this (see figure I) scale

employing 48 items each rated on a 5 point scale of distress (0-4) ranging from "not at all" at one pole to "extremely" at the other.

This modified scale is interpreted in terms of 5 primary symptom dimensions and 3 global indices of distress.

Somatisation

Depression

Anxiety

Hostility

Additional

Global Severity Index (GSI)

Positive Symptom Distress Index (PSDI)

Positive Symptom Total (PSI)

The global indices have been developed to provide flexibility in the overall assessment of the patients psychological status. They communicate in a single score the level of depth of the individuals psychopathology. The GSI represents the best single indication of the depth of the disorder. The PSDI was a pure measure of the intensity, in a sense corrected for numbers of symptoms. The PST was simply a count of the number of symptoms that the patient reports were positive.

Test Administration and Scoring

Under usual circumstances the modified SCL was completed by the patient within 5-10 minutes. If necessary I would personally go through the questionnaire with the patient,

The raw scores for symptomatic dimensions together with the 3 global scores were converted into T-scores, by plotting the

individual patient's raw score on the gender appropriate normal data sheet (provided with the manual Derogatis 1974). The relative T-score normalised these volumes and communicated the patients centile position relative to the norm (t=50). Thus a T score of 60 regardless of which symptom will place an individual in the 84th percentile of the normative sample.

Interpretation of the SCL Symptom Profile

The SCL was evaluated in terms of global, dimensional and symptomatic. The GSI reflected the overall level of distress. The symptom dimensions communicated the nature as well as the intensity of the individuals psychological symptoms and provided important data concerning the pattern of a patients symptomatology,

Normative Samples

The sources of normative data and descriptions were carefully outlined in the manual (Derogatis 1974). They included a sample of 1002 heterogenous psychiatric outpatients, 974 normal volunteers and a sample of 112 adolescent psychiatric outpatients.

Reliability of the SCL

Reliability measures concerning the primary symptom dimensions of the SCL are essentially of two types. Internal consistency and Test-Retest reliability.

The former serve to measure the homogeneity or consistency with which the items selected represent each symptom. Test and retest reliability is essentially a measure of stability of measurement across time.

Internal consistency for the symptom dimension ranges from 0.84-

0.90 and Test-retest reliability 0.78-0.86 (Derogatis 1974).

Profile of Mood Scores (POMS)

The POMS has been developed by McNair et al 1974, and measures 5 identifiable mood or affective states; Tension-Anxiety, Depression-Dejection, Anger-Hostility, Vigor-Activity, Fatigue-Inertia (see figure 2).

The data has been derived from 3 main sources:

1. Experimental clinical research
2. Routine clinical assessment program in a major university medical centre psychiatry clinic.
3. Selected samples of normal college students.

The questionnaire included 55 items rated on a 0-4 point intensity scale 0 = not at all, 4 = extremely,

Profile sheets were available for plotting POMS results on appropriate normal data sheets. When raw scores were plotted they automatically were converted into standard T-scores. The mean standard score for each scale was 50 with a standard deviation of 10. Thus approximately 95% of the population upon which the norms were based fell between standard scores of 30 and 70 for any given scale. The POMS was self administrating for almost all the patients. Most subjects completed the POMS in about 3-5 minutes.

Scoring

To obtain a score for each mood factor, the sum of the responses was obtained. A Total Mood Disturbance Score was obtained by summing the scores (with vigor weighted negatively) for the 5 primary mood factors.

A Total Mood Disturbance Score can be presumed to be highly

reliable because of the intercorrelations among the five primary POMS factors (Unfortunately there was no normative data available for the final Total Mood Disturbance Score and hence it could only be expressed as a raw value rather than as a T-score).

Reliability of POMS Factors;

All 5 mood scales have internal consistencies of 0.9 and re-test reliability of 0.61-0.69. In addition in several studies one or more of the POMS factors have proved sensitive to the effects of psychotherapy.

Fatigue Score

A fatigue score (as defined by Christensen et al 1982) was defined by a self assessment questionnaire. The fatigue scale (Figure III) was modified from that originally described and included 10 increments ranging from 1 (fit) to 10 (fatigued). The scale quantified the subjective feelings of fatigue associated with daily tasks eg., housework, walking etc., The patient simply indicated where they felt they lay on this 10 point scale. This was performed following completion of the POMS questionnaire.

FIGURE LEGENDS

Figure I

The modified SCL self questionnaire

Figure II

The POMS self questionnaire

Figure III

The modified Fatigue-scale

FIGURE I

INSTRUCTIONS

Below is a list of problems and complaints that people sometimes have. Read each one carefully and select one of the numbered descriptions that best describes HOW MUCH DISCOMFORT THAT PROBLEM HAS CAUSED YOU DURING THE PAST WEEK INCLUDING TODAY. Place that number in the open block to the right of the problem. Do not skip any items and print your number clearly. If you change your mind, erase your first number completely. Read the example below before beginning, and if you have any questions please ask the doctor.

EXAMPLE	
<p>HOW MUCH WERE YOU DISTRESSED BY:</p> <p>Example: Body aches <input style="width: 20px; text-align: center;" type="text" value="3"/></p>	<p><u>Descriptions</u></p> <p>0 Not at all</p> <p>1 A little bit</p> <p>2 Moderately</p> <p>3 Quite a bit</p> <p>4 Extremely</p>

1 Headaches	<input type="checkbox"/>	26 Trouble getting your breath ..	<input type="checkbox"/>
2 Nervousness or shakiness inside	<input type="checkbox"/>	27 Hot or cold spells	<input type="checkbox"/>
3 Faintness or dizziness	<input type="checkbox"/>	28 Numbness or tingling in parts of your body	<input type="checkbox"/>
4 Loss of sexual interest or pleasure	<input type="checkbox"/>	29 A lump in your throat	<input type="checkbox"/>
5 Feeling easily annoyed or irritated	<input type="checkbox"/>	30 Feeling hopeless about future ..	<input type="checkbox"/>
6 Pains in chest or heart	<input type="checkbox"/>	31 Weakness in parts of body	<input type="checkbox"/>
7 Feeling low in energy or slowed down	<input type="checkbox"/>	32 Feeling tense or keyed up	<input type="checkbox"/>
8 Thoughts of ending your life	<input type="checkbox"/>	33 Heavy feelings in arms & legs	<input type="checkbox"/>
9 Trembling	<input type="checkbox"/>	34 Thoughts of death or dying ...	<input type="checkbox"/>
10 Poor appetite	<input type="checkbox"/>	35 Overeating	<input type="checkbox"/>
11 Crying easily	<input type="checkbox"/>	36 Having urges to injure or harm someone	<input type="checkbox"/>
12 Feelings of being trapped or caught	<input type="checkbox"/>	37 Waking early in the morning ..	<input type="checkbox"/>
13 Suddenly scared for no reason	<input type="checkbox"/>	38 Disturbed or restless sleep ..	<input type="checkbox"/>
14 Temper out bursts that you can't control	<input type="checkbox"/>	39 Urges to break or smash things	<input type="checkbox"/>
15 Blaming yourself for things	<input type="checkbox"/>	40 Feeling everthing is an effort	<input type="checkbox"/>
16 Pains in lower back	<input type="checkbox"/>	41 Spells of terror or panic	<input type="checkbox"/>
17 Feeling lonely	<input type="checkbox"/>	42 Getting into frequent arguments	<input type="checkbox"/>
18 Feeling blue	<input type="checkbox"/>	43 Feeling so restless you can't sit down	<input type="checkbox"/>
19 Worrying too much about things	<input type="checkbox"/>	44 Feelings of worthlessness	<input type="checkbox"/>
20 Feeling no interest in things	<input type="checkbox"/>	45 Feeling something bad is going to happen	<input type="checkbox"/>
21 Feeling fearful	<input type="checkbox"/>	46 Shouting or throwing things ..	<input type="checkbox"/>
22 Heart pounding or racing	<input type="checkbox"/>	47 Thoughts or images of a frightening nature	<input type="checkbox"/>
23 Nausea or upset stomach	<input type="checkbox"/>	48 Feelings of guilt	<input type="checkbox"/>
24 Soreness of muscles	<input type="checkbox"/>		
25 Trouble falling asleep	<input type="checkbox"/>		

FIGURE II

POMS

Below is a list of words that describe feelings people have. Please read each one carefully and select one of the numbered descriptions that best describes HOW YOU HAVE BEEN FEELING DURING THE PAST WEEK INCLUDING TODAY.

The numbers refer to these phrases:

- 0 Not at all
- 1 A little
- 2 Moderately
- 3 Quite a bit
- 4 Extremely

1	Friendly	<input type="checkbox"/>
2	Tense	<input type="checkbox"/>
3	Angry	<input type="checkbox"/>
4	Worn out	<input type="checkbox"/>
5	Unhappy	<input type="checkbox"/>
6	Clear-headed	<input type="checkbox"/>
7	Lively	<input type="checkbox"/>
8	Sorry for things done	<input type="checkbox"/>
9	Shaky	<input type="checkbox"/>
10	Listless	<input type="checkbox"/>
11	Peeved	<input type="checkbox"/>
12	Considerate	<input type="checkbox"/>
13	Sad	<input type="checkbox"/>
14	Active	<input type="checkbox"/>
15	On edge	<input type="checkbox"/>
16	Grouchy	<input type="checkbox"/>
17	Blue	<input type="checkbox"/>
18	Energetic	<input type="checkbox"/>
19	Panicky	<input type="checkbox"/>
20	Hopeless	<input type="checkbox"/>
21	Relaxed	<input type="checkbox"/>
22	Unworthy	<input type="checkbox"/>
23	Spiteful	<input type="checkbox"/>
24	Sympathetic	<input type="checkbox"/>
25	Uneasy	<input type="checkbox"/>
26	Restless	<input type="checkbox"/>
27	Fatigued	<input type="checkbox"/>

28	Helpful	<input type="checkbox"/>
29	Annoyed	<input type="checkbox"/>
30	Discouraged	<input type="checkbox"/>
31	Resentful	<input type="checkbox"/>
32	Nervous	<input type="checkbox"/>
33	Lonely	<input type="checkbox"/>
34	Miserable	<input type="checkbox"/>
35	Cheerful	<input type="checkbox"/>
36	Bitter	<input type="checkbox"/>
37	Exhausted	<input type="checkbox"/>
38	Anxious	<input type="checkbox"/>
39	Ready to fight	<input type="checkbox"/>
40	Good natured	<input type="checkbox"/>
41	Gloomy	<input type="checkbox"/>
42	Desperate	<input type="checkbox"/>
43	Sluggish	<input type="checkbox"/>
44	Rebellious	<input type="checkbox"/>
45	Helpless	<input type="checkbox"/>
46	Weary	<input type="checkbox"/>
47	Alert	<input type="checkbox"/>
48	Deceived	<input type="checkbox"/>
49	Furious	<input type="checkbox"/>
50	Trusting	<input type="checkbox"/>
51	Full of pep	<input type="checkbox"/>
52	Bad-tempered	<input type="checkbox"/>
53	Carefree	<input type="checkbox"/>
54	Terrified	<input type="checkbox"/>
55	Guilty	<input type="checkbox"/>
56	Vigorous	<input type="checkbox"/>
57	Bushed	<input type="checkbox"/>
58	Worthless	<input type="checkbox"/>

FIGURE III

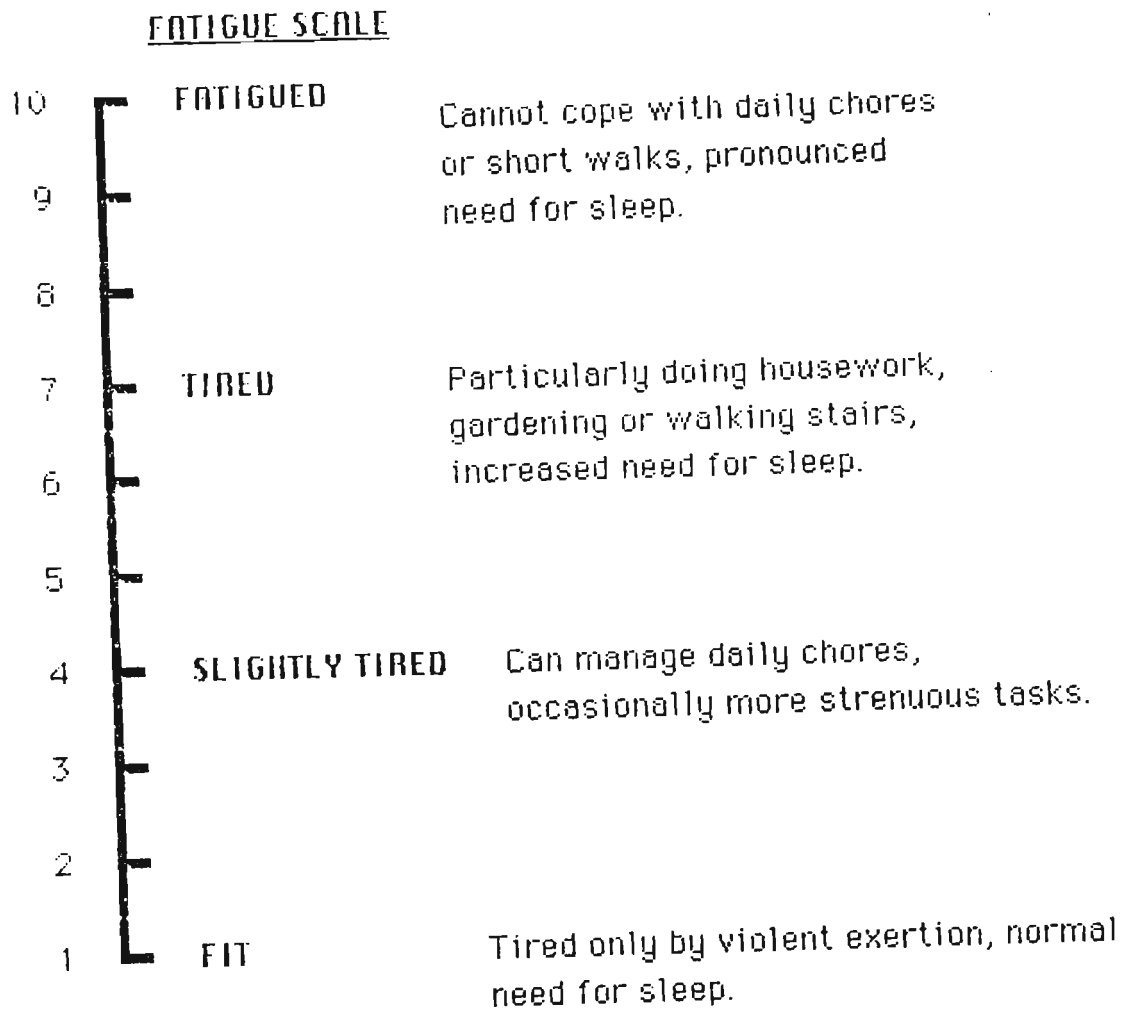

CHAPTER 13 INTRAVENOUS NUTRITION

All patients receiving IVN were fed exclusively by the parenteral route for the duration of the 14 days study period. The nutrient solution contained synthetic aminoacids (Synthamin 10%) and calories as 50:50 dextrose: intralipid mixture. The prescription was for total energy intake of 40 Kcals/Kg/day with a calorie to nitrogen ratio of 150:1. The solutions were made up into 3 litre bags for infusion through a constant volumetric infusion pump (IVAC) into a central venous cannula. Careful fluid balance was observed for all patients and hence knowing the volume of IVN received by each patient, the total energy received could be quantified. Electrolytes, minerals, trace metals and vitamins were added to the nutrient solution as appropriate. In the University Department of Surgery, Auckland Hospital we have had a major interest in IVN for a number of years. It can be seen from Figures 1,2,3, that approximately one hundred patients are fed each year for approximately 17 days. It can also be clearly seen that by far the biggest individual clinical group presenting for IVN are those patients suffering from IBD. For specific details concerning the patient selection, for IVN and other medical therapy etc., for the group of patients described in this thesis please see Chapter 20.

FIGURE LEGENDS

Figure I

Number of patients receiving IVN, Department of Surgery,
University of Auckland, 1983-1987

Figure II

Average duration of IVN for individual patients, Department of
Surgery, University of Auckland 1983-1987

Figure III

Disease breakdown for group receiving IVN during 1987.

FIGURE I

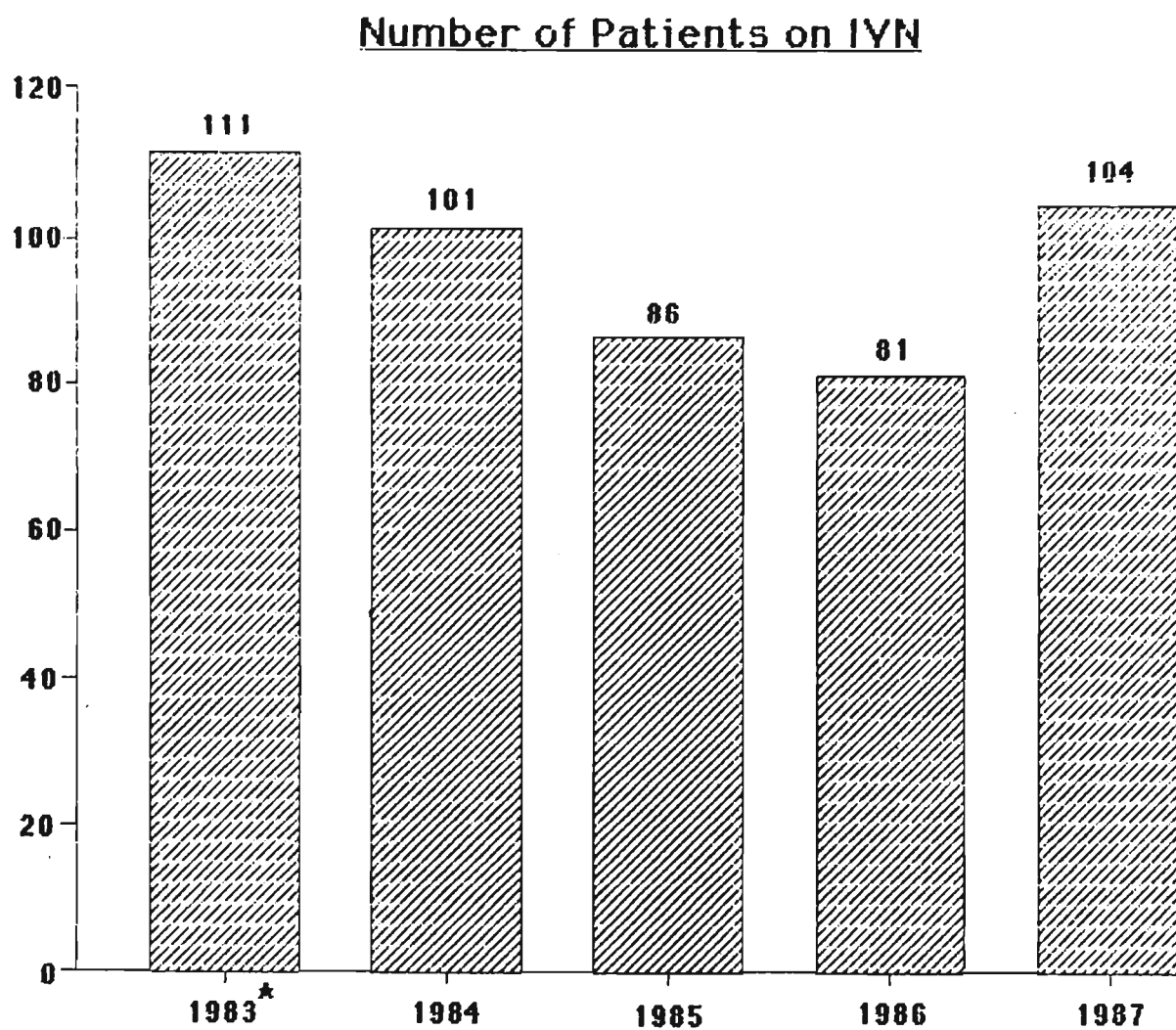

* Linearly extrapolated from last 4 months.

FIGURE II

Average Time Spent on IYN

DAYS

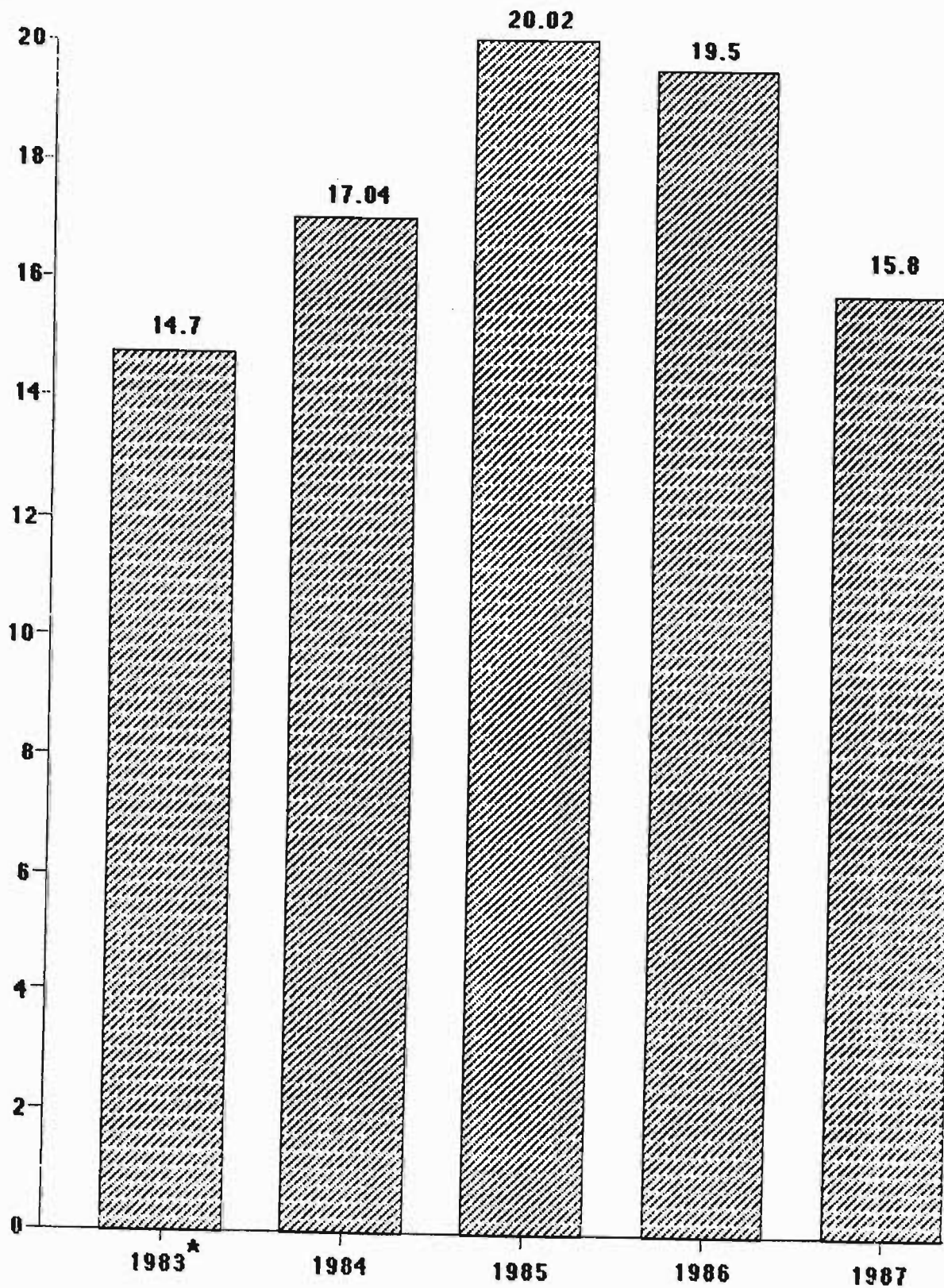

* Linearly extrapolated from last 4 months.

FIGURE III

1987 IYN Disease Categories

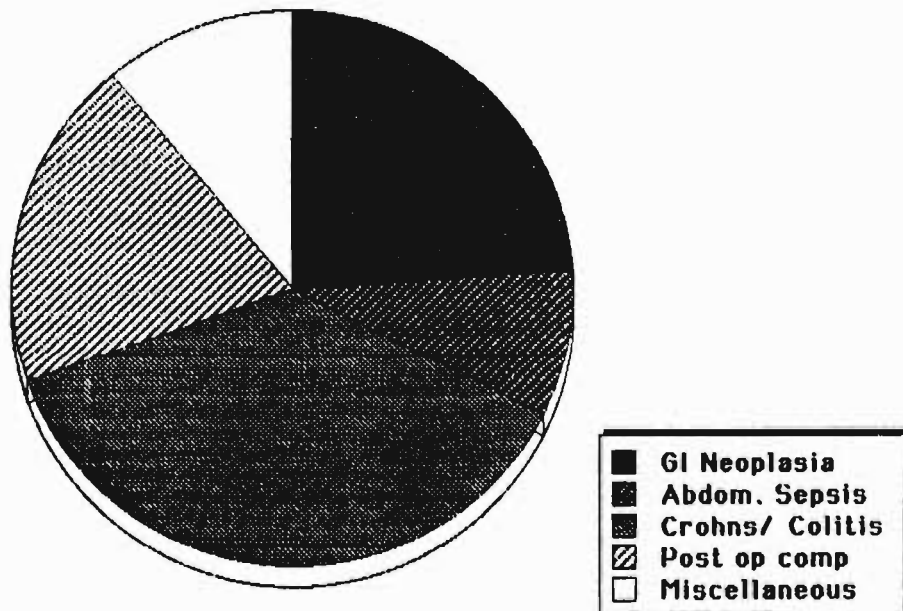

CHAPTER 14 : EXPERIMENTAL PROTOCOL

Immediately after the RME had been measured, body weight and height were measured. After removing 30 mls of venous blood for plasma protein measurements, tritium and bromide background, each patient received 3.7 MBq (110uCi) of tritiated water together with 50 mls of a 5% solution of NaBr (if in protocol) intravenously and was then scanned in the IVNAA facility for 36 minutes. Some of the patients in the studies preceded this scan by a TBK estimation. A 20 ml venous blood sample was taken 2.5 hours after $3\text{H}_2\text{O} \pm (\text{NaBr})$ injection to estimate total body water (and ECW).

Following completion of body composition measurements these patients while in the department also underwent objective testing of voluntary and involuntary skeletal muscle function together with tests of respiratory muscle function. Gore-Tex insertion and explanation and administration of psychological tests were performed at the bedside later that day.,

The tests of body composition plasma proteins, resting energy expenditure, skeletal and respiratory muscle function together with psychological and wound healing function were performed at weekly intervals over the period of IVN ie, on day 0, the day prior to commencement of IVN, and following 7 and 14 days of IVN.

CHAPTER 15 : STATISTICAL METHODS

Student's 't' test

The Students 't' test (paired) has been used in this thesis to determine the significance of changes in patients measured values and to compare the patients measured values with that of their matched controls.

I have agonised over the proper statistical treatment and presentation of my patient sequential data eg., following surgery, Chapter 17, and following nutritional intervention Chapters 21,22. Generally the statistical analysis of data using paired 't' testing repeatedly is inappropriate. However, following collaboration with no less an an authority then biostatistian Dr Lewis Burkinshaw it was concluded that paired 't' testing was appropriate and correct in this setting. For instance if the ANOVA or Scheffe's test was applied to the data in Chapters 21, 22, then as might be expected these conservative tests showed less convincing p values, but there were few differences in any of the significant changes shown in my tables. Validity of my choice of statistical methods was further confirmed by the initial examination of this data with and without the control group present with a one way ANOVA as it would be conceivable that the controls maybe in some way dissimilar or may also change with time etc., Relative to patients irrespective of the controls being present or absent in the analysis a significant difference was still found. This significant difference relates chiefly to the relatively larger differences between patient's respective

parameters over the treatment period to that at the time of recovery. Nevertheless, it does mean however that it is permissible to examine the changes of day 0 to day 7, and day 7 to day 14 more closely.

One-way Analysis of Variance (ANOVA)

This test has been used to compare quantitative data when there are more than 2 groups of unpaired data. It simply compares the differences between the group means as compared within group variation. If each sample is from a normal distribution then estimates of the variances can be compared by considering the ratios of the variance estimates i.e., the F statistic, which is documented for varying sample sizes and levels of confidence.

Chi-Squared (χ^2) test

This analysis with the Yates correction factor has been employed to compare qualitative data.

Wilcoxon Signed Rank Sum Test

When the quantitative data could not be assumed to be normally distributed the Wilcoxon non parametric test was employed. Nevertheless it is a well accepted test with critical values provided in standard tables for the 5% and 1% level of confidence.

SECTION 3 : THE PROBLEM OF PROTEIN ENERGY MALNUTRITION

CHAPTER 16 : CHANGES IN THE BODY STORES OF PROTEIN, FAT AND WATER
IN IBD - A BODY COMPOSITIONAL SURVEY

Introduction

The extent and severity of PEM in patients suffering from IBD is not known. Previous studies eg., (Hill et al 1977, Driscoll 1978 and Harries et al 1982) have relied heavily on indirect measurements of nutritional assessment (Grant 1986).

Furthermore the effects of PEM are far reaching ranging from energy (Higgins et al 1982) and impaired skeletal muscle function (Lopes et al 1982), to local adverse effects on gastrointestinal function and structure (Brown et al 1963). It is also clear that PEM has been associated with an increased post-operative morbidity and mortality (Kushner et al 1982).

In this section I have set out to objectively examined the "Problem" in patients presenting with various clinical presentations of IBD. In particular, I have directly measured the body stores of protein, fat and water, together with measurements of resting energy expenditure. It was hoped that a clear appreciation of the severity and extent of PEM will be gained and a useful discrimination between the clinical groups presenting for nutritional support will emerge. I have therefore examined the body compositional records of 170 clinical presentations of IBD in the same clinical categories (as in the previous paper, Hill et al 1977b): Ileostomy and J-pouch (42); remission (16), elective surgery

(12) acute attack (54) urgent surgery (17) and post-surgical complications (12).

Patients and Methods

A retrospective analysis of the body composition records of 107 patients was carried out covering a 6 year period from January 1983 to October 1988. 54 patients had presented on more than one occasion (45 patients twice, and 9 patients three times). As these presentations were separated by a long period of time, and their presentations in each case were quite different, I have used them as though they were separate patients. Hence analysis was carried out on 170 clinical presentations.

In all cases the diagnosis of IBD had been well established and the clinical presentations were grouped into six categories according to the previous paper by Hill et al 1977b. The assessment of disease severity was defined by the criteria of Truelove and Witts 1955; in the case of ulcerative colitis and according to the Crohn's Disease Activity Index (Best et al 1976), in the case of Crohn's disease. The ileostomy and J-pouch patients were an unselected group of patients attending regular follow-up. The patients in this group were all studied consecutively over a number of weeks as outpatients. The remission group comprised a further selected group of patients, who had to have quiescent disease. These patients were also studied consecutively as outpatients over a number of weeks for the purpose of this review.

The remainder of this review reports patient information that was extracted retrospectively from the body compositional records (Department of Surgery, University of Auckland) covering the period January 1983 - October 1988. These records were chiefly of those patients who presented with either acute presentations of IBD or had developed a post-operative complication following emergency or elective

surgery. For the majority of those patients the body compositional assesment was performed prior to commencement of IVN.

Body Compositional Methods

Assessment of protein depletion and fat depletion was made through direct measurements of total body protein and total body water based on a five compartment model of the human body. The ratio of TBW:FFM was used as an index of hydrational status. The methodology and precision of these measurements is discussed in chapter 5.

Assessment of Metabolic Stress

As outlined in chapter 6, metabolic stress was defined by relating a measurement of Resting Metabolic Expenditure (RME) determined by indirect calorimetry to predicted normal values of RME derived from regression equations.

Hepatosecretory Proteins

Plasma transferrin, pre-albumin and albumin levels were determined from venous blood samples taken from patients by standard methods as outlined in Chapter 7

Skeletal Muscle Function

As a test of Voluntary Skeletal Muscle Function, Maximal Voluntary Grip Strength was measured. (see Chapter 10). During the period of this review the instrument for measuring grip strength changed. Half the patients had grip strength measured using a vigorimeter (Ortopedia, West Germany) with a 50 mm bulb, producing a reading in kilopascals.

The second ,latter half of the group had grip strength measurements using a vigorimeter reading in Kgs. To allow a comparable measurement for every patient, grip strength was reported as percentage of predicted grip strength. There was a large normal data base for both instruments allowing calculation of linear regression equations to predict grip strength based on age, sex and height. The standard deviations for the patients about their mean were similar for the two instruments (See Chapter 10).

Statistical analysis

Quantitative data of these six groups was compared with a one way analysis of variance (ANOVA).

Multiple group comparisons of these quantitative data were done using the Fisher PLSD test, and the multi comparison significance level was 95%.

Comparison of these quantitative group data to that of normal control data was done using Student's 't' test. Categorical data including the disease frequency in the various six categories were evaluated using the chi-square test with the Yates correction.

Results

All raw data of the patients in this study appears at the end of this chapter.

Table I shows the age, sex, weight, resting energy expenditure, diagnosis and clinical findings of the six categories to which the patients were allocated.

Patients in the remission category, (15 of whom were suffering from Crohn's disease) together with the acute presentation groups weighed significantly less than the patients with well functioning ileostomies, J-pouches and those patients presenting for elective surgery (mainly colitis).

All six groups had significantly increased resting energy expenditures ($P < 0.05$) when compared with normal control values.

There were proportionally more patients with Crohn's disease in the remission and acute non-surgical category than patients with ulcerative colitis. Significantly less Crohn's patients came to elective surgery, but equal ratios of Crohn's and ulcerative colitis patients required emergency surgery. These patients experienced an equivalent complication rate.

Table II shows the mean values for protein and fat storage expressed both directly and as a percentage of predicted control values, for each of the six clinical categories. Also shown are the mean values for: the hydration of the fat free body mass, hepatosecretory proteins, maximal voluntary grip strength, and the percentage weight loss of the six groups.

Patients presenting acutely with IBD had sustained significant weight loss. This was especially seen in the group of patients that came to urgent surgery. Severe protein depletion was uniformly present in patients with acute presentations of their disease. This was particularly maximal in those patients who had sustained a major complication following surgery. Less severe degrees of protein depletion was still present, however, in both the remission group and in those patients coming to elective surgery. Patients with well functioning ileostomies and J-pouches were however, found to have near normal protein stores.

Fat stores were found to be normal for all groups except the post surgical complication group. This group had significantly reduced fat stores ($P < 0.05$).

The hydrational status TBW/FFM for all groups with the exception of ileostomy and J-pouch was significantly increased from normal controls (normal: 0.726 ± 0.002), $P < 0.01$. There was a tendency for this overhydration to be most evident in those patients who sustained a major complication.

Patients who presented as emergencies; acute attack, urgent surgery and post-surgical complications, had significant lowering of plasma albumin, transferrin and pre-albumin. These values tended again to be lowest in those patients who had developed major complications after surgery. Finally in table II, as a test for skeletal muscle function, the average value for grip strength is shown (expressed as percentage of predicted).

Patients with active disease, together with those in the remission category were found to have significantly impaired grip strengths when

compared with normal controls $P < 0.01$ and $P < 0.05$ respectively (normal; $1.00 \pm 0.16(\text{SD})$). Grip strength was impaired further ($P < 0.05$) in those patients who had sustained a major complication.

In the 42 patients with well functioning ileostomies and J-pouches, together with those 29 patients presenting for elective surgery, grip strength was not found to be different from the controls.

Table III shows for each nutritional parameter the percentage of patients in each of the six clinical categories that were below the 95 percentage range from the normal control data.

I took an arbitrary weight loss of 10% as by definition all the local normal controls had not lost weight and hence it was not possible to develop 95 percent confidence limits for this index.

This table shows, as would be expected from the data in table II, the frequency of abnormal values was greatest in those patients who developed complications after surgery (43-100%). The frequency of abnormal values was also high in patients who presented with an acute attack (32-73%) and in those patients who required urgent surgery (28-83%). It can also be seen from table III that not all of the indices were successful at discriminating between the patients in the six clinical categories.

Interestingly the clinical parameters; weight loss, plasma, albumin, pre-albumin and maximal voluntary grip strength were found sensitive and closely paralleled the incidence of protein depletion in these patients.

Table IV compares the values of these nutritional indices for the two diseases, in the 3 acute presentation categories. The magnitude of impairment was similar, but Crohn's patients had lost more of their

protein stores and tended to have a more impaired grip strength. There was also a tendency for all 3 acute categories of ulcerative colitis patients to have increased elevations of resting energy expenditure compared with Crohn's patients, but this did not reach statistical significance.

Discussion

This present series demonstrated that protein depletion was a severe and common problem in patients suffering from acute exacerbations of IBD. It was present in a wide range of clinical presentations. Protein depletion was severe in patients who presented acutely and required urgent surgery. The extra stress of a major surgical complication was well demonstrated with a progressive tendency for a further fall in protein stores.

Similar high levels of protein depletion were present in the acute exacerbations of both Crohn's and ulcerative colitis. This was contrary to some reports (Harries et al 1982) suggesting lesser degrees of protein depletion with ulcerative colitis.

Protein depletion was not confined only to patients with acute illness. A less severe degree of protein depletion was present in patients who were clinically in remission, and also in those patients presenting for elective surgery. The only group that were found to have near normal protein stores were the group of fully convalescent patients who had well functioning ileostomies and J-pouches (performed chiefly for colitis).

Fat stores were not depleted significantly except in those patients who had suffered a major surgical complication. This relative preservation of fat stores in the presence of depleted protein stores has been noted by other investigators (Moore et al 1963) and reflected the effects of major surgical stress and concomitant steroids. Furthermore convalescent ileostomy and J-pouch patients tended to have increased fat stores. This was contrary to the findings of Cooper et al 1986. The patients

displayed increased resting energy expenditures. This was especially seen in the two acute presentation groups. This was contrary to some previous reports (Barot et al 1982). My results suggested a 20% elevation of REE when this was appropriately indexed to the fat free body mass. This elevation was especially marked in patients suffering from acute exacerbations of ulcerative colitis. Unfortunately the two outpatient groups: ileostomy/J-pouch and the remission group had not been starved preceding this measurement. Hence their increased REE most likely represented the thermogenic effects of their recent food intake and comparison of their data with the other groups cannot be made.

Groups of patients found to be protein depleted had also increased body stores of water when compared to normal controls. This was in agreement with the findings of Dr Moore (Moore et al 1963). It was also interesting that the ileostomy and J-pouch group were found to have normal stores of body water. This was contrary to the widely accepted belief that the presence of an ileostomy led to a state of chronic dehydration (Clarke et al 1967b).

Plasma protein levels were found to be significantly lowered in the three acute presentations categories, consistent with their high disease activity, and lowered protein stores. This was in keeping with earlier reports (Hill et al 1977b, Driscoll et al 1978, and Weeke et al 1971). Not only were the mean levels for the acute groups significantly lower, but there were high frequencies of patients in these groups with significantly low levels of pre-albumin and albumin ranging from 55% in the group having urgent surgery to 100% for the group experiencing complications. Plasma transferrin levels proved less sensitive e.g. only

43% of the patients in the complication group had significantly low levels.

Grip strength has been previously shown not only to correlate well with protein loss (Windsor et al 1986b) but can also identify a surgical group of high risk (Klidjian et al 1980). The results of this study were in agreement. The grip strengths for the remission group were however also significantly impaired, consistent with their measured lower protein stores and this must indicate that despite their "quiescent" clinical appearance, these patients remain of increased surgical risk.

The acute presentation groups represented a selected hospital population, but nevertheless were typical of any hospital population suffering from acute exacerbation of IBD. They were furthermore similar to the previous Leeds series (Hill et al 1977b) and therefore I am confident that I have not over-emphasised the severity and extent of protein depletion in this group of patients. The outpatients were a typical group of such patients with IBD attending regular follow up. With respect to the question of precision for the measurement of protein and fat stores, these were direct measurements with good precision (see methods chapter 5) and hence were not subject to the problems with anthropometry when it was used in such patients (Streat et al 1985).

These objective measurements of body composition successfully validate the importance of the 6 clinical categories in assessing protein energy malnutrition.

In addition I introduced and demonstrated the importance of skeletal muscle function in the assessment of these patients. Grip strength was found to be significantly impaired when the patients had suffered severe protein loss, culminating in a surgical complication.

The prevalence of PEM was at least as high as suggested by previous reports (Hill et al 1977b, Driscoll et al 1978, Harries et al 1982). The results of this study demonstrate that a proportion (44%) of patients who were felt to have quiescent disease (chiefly Crohn's) remained significantly protein depleted, despite a reasonable period of convalescence.

I conclude that protein energy malnutrition remains a major problem for patients suffering from IBD. This was especially true for patients suffering from acute exacerbations of IBD, but lesser degrees of this problem still existed even in patients in clinical remission. Nutritional assessment and possibly intervention must therefore be strongly recommended for all patients presenting to the hospital with acute exacerbations of their disease.

Tests of skeletal muscle function may be a helpful adjunct when performing a nutritional assessment.

Furthermore this retrospective body compositional survey raises some additional questions:

First - what would be the effects of nutritional intervention in such a heterogenous group? Any improvement during nutritional therapy would have to be examined not only in terms of improvement in protein stores, but also in terms of improvement in physiological functions eg., respiratory and skeletal muscle function. It would also be important to relate the magnitude of any improvement in these systems to the level of persisting impairment still present late in the convalescent period. Secondly - this survey has demonstrated for the first time, normal stores of protein and water after surgery for colitis. There is therefore a necessity to test the validity of these observed changes

after surgery and also the timing of these changes would be of most interest, not only to the surgeon, but also to the young patient wanting to learn more of the nature of his recovery.

I will describe my work directed at addressing these important areas in the next few sections of this thesis.

LEGENDS FOR TABLES

- Table I Shows the age, sex, weight, resting energy expenditure and diagnoses for six clinical categories
- Table II Shows the mean values of protein and fat stores for the six clinical categories. Also shown are the mean values of: the hydration of the fat free body mass; hepatosecretory proteins maximal voluntary grip strength and percentage weight loss.
- Table III Shows the percentage of low values (< lower limit of 95% range of normal) for the various nutritional indice in each of the six clinical categories
- Table IV Shows a breakdown of the mean value of each nutritional indice in the 3 acute presentations categories, for both Crohn's and ulcerative colitis patients.

TABLE I

CLINICAL DETAILS

Category	Sex M F	Age (yr)		Height (cm)		Weight (kg)		BME (Kcal/24 hr)		Predicted	Diagnosis	Comment
		$\bar{x} \pm SD$	Range	$\bar{x} \pm SD$	Range	$\bar{x} \pm SD$	Range	Measured	Predicted			
Ileostomy and J-pouch (n=42)	22	20	39 \pm 14	17-14	169 \pm 9	152-187	66 \pm 14	43-101	1449 \pm 43	1325 \pm 45	110 \pm 3	38 UC 4 Crohns 22 patients with well functioning ileostomies established more than 1 year. 20 patients with well functioning J-pouches ileostomy closed more than 6 months 4 patients with previous Crohns colitis free of small bowel disease
Remission (n=16)	7	9	29 \pm 9	17-50	166 \pm 11	152-195	58 \pm 13	43-90	1317 \pm 66	1143 \pm 41	115 \pm 3	1 UC 15 Crohns p<0.001 All patients had a long history of IBD but had quiescent disease - stable weight and no symptoms suggestive of active disease
Elective Surgery (n=29)	15	14	31 \pm 8	14-48	170 \pm 11	153-188	67 \pm 15	43-90	1465 \pm 64	1231 \pm 39	119 \pm 3	26 UC 3 Crohns p<0.0008 Surgery for long-standing colitis or chronic continuous disease
Acute Attack (n=54)	27	27	38 \pm 19	15-87	166 \pm 10	149-189	50 \pm 11	31-79	1306 \pm 38	1085 \pm 17	120 \pm 3	17 UC 37 Crohns p<0.0007 UC - all severe disease extending above rectum which failed to remit after Prednisone 20mg/day for 3 weeks. Crohns mainly small bowel strictures but 6 severe Crohns colitis and 4 fistulae, CDAI 282 \pm 120 SD
Urgent Surgery (n=17)	11	6	38 \pm 16	18-74	170 \pm 8	156-186	57 \pm 11	43-81	1431 \pm 58	1155 \pm 31	124 \pm 4	7 UC 10C Crohns NS 7 acute exacerbations that failed to remit after 0-7 days in hospital. UC - all severe. For Crohns CDAI: 244 \pm 97 SD included 2 toxic megacolon: 3 fulminating colitis and 1 fistula
Post surgical complications (n=12)	6	6	30 \pm 9	22-47	169 \pm 12	155-195	51 \pm 15	30-74	1339 \pm 98	1154 \pm 72	116 \pm 4	7 UC 5 Crohns NS All except 2 patients had undergone surgery for acute disease. Mainly post-operative sepsis, 3 with fistulas, but 2 obstructions and 1 wound dehiscence
ANOVA F			2.54		1.29		9.41				0.91	
P			0.03		NS		0.001				NS	

TABLE II

INDICES OF PROTEIN-ENERGY MALNUTRITION IN PATIENTS WITH INFLAMMATORY BOWEL DISEASE

Category	Weight Loss (%)	Protein Stores TBP (kg)		Fat Stores TBF (kg)		Hydrational Status	Hepatic Secretory Proteins			Skeletal Muscle Function		
		Measured	%Predicted	Measured	%Predicted		Plasma Albumin (gm/L)	Plasma Transferrin mg/dl	Plasma prealbumin mg/dl			
Ileostomy and J-pouch	-0.5 ± 1.1	9.6 ± 0.4	10.4 ± 0.4	92 ± 2	17.0 ± 1.1	16.0 ± 0.5	106 ± 6	0.740±0.004	43 ± 1	277 ± 10	28.9 ± 1.0	95 ± 3
Remission	-0.8 ± 1.8	8.0 ± 0.5	9.9 ± 0.7	83 ± 4	12.8 ± 1.6	14.2 ± 1.1	98 ± 9	0.748±0.004	38 ± 1	281 ± 25	26.0 ± 2.0	84 ± 4
Elective Surgery	1.3 ± 1.6	9.2 ± 0.6	11.0 ± 0.7	85 ± 3	17.0 ± 1.4	15.6 ± 0.7	111 ± 9	0.748±0.004	40 ± 1	268 ± 16	27.7 ± 1.5	91 ± 3
Acute Attack	13.0 ± 1.0	6.8 ± 0.3	9.3 ± 0.3	73 ± 2	11.6 ± 1.0	13.8 ± 0.9	98 ± 10	0.751±0.004	34 ± 1	215 ± 11	20.4 ± 1.3	73 ± 4
Urgent Surgery	16.0 ± 2.0	8.1 ± 0.6	10.7 ± 0.6	75 ± 3	11.6 ± 1.7	14.3 ± 1.0	82 ± 9	0.747±0.003	33 ± 1	216 ± 14	20.5 ± 1.3	82 ± 6
Post Surgical Complications	17.0 ± 3.0	7.1 ± 1.0	10.4 ± 0.9	67 ± 5	8.8 ± 1.7	12.7 ± 1.0	68 ± 12	0.763±0.006	33 ± 1	193 ± 10	14.4 ± 1.8	57 ± 11
ANOVA												
F	24.98			12.73			1.48	1.13	11.76	5.24	8.07	5.50
P	<0.0001			<0.0001			NS	NS	<0.0001	<0.0002	<0.0001	<0.0001

All data are $\bar{x} \pm SEM$

TABLE III

PERCENTAGE OF LOW VALUES (<LOWER LIMIT OF 95 PERCENT RANGE OF NORMAL)

FOR NUTRITIONAL INDICES IN PATIENTS WITH INFLAMMATORY BOWEL DISEASE

<u>Category</u>	<u>Weight Loss</u> (<10%)	<u>Protein Stores</u> (<81% predicted)	<u>Fat Stores</u> (<40% predicted)	<u>Hepatic Secretory Proteins</u>			<u>Skeletal Muscle Function</u>	
				<u>Plasma Albumin</u> <34 (gm/L)	<u>Plasma Transferrin</u> <176 (mg/dl)	<u>Plasma Prealbumin</u> <22 (mg/dl)	<u>Grip Strength</u> (<60% predicted)	
Ileostomy and J-pouch	7	14	2	6	0	9	0	
Remission	6	44	12	0	7	25	5	
Elective Surgery	21	24	3	4	8	17	10	
Acute Attack	70	66	15	55	23	73	32	
Urgent Surgery	83	61	11	50	29	56	28	
Post Surgical Complications	83	75	20	71	43	100	78	

TABLE IV

INDICES OF PROTEIN ENERGY MALNUTRITION - CROHN'S VS ULCERATIVE COLITIS

	Weight Loss (%)	RME % predicted	Protein Stores (TBP) % predicted	Fat Stores TBF % predicted	Hepatic Secretory Proteins Plasma		Skeletal Muscle Function	
					Albumin (gm/l)	Transferrin (gm/dl)	Prealbumin (gm/dl)	Grip Strength (% predicted)
Acute attack	Crohns	13.2 ± 1.4	119 ± 4	108 ± 15	33 ± 1	204 ± 14	26.3 ± 0.6	69 ± 4
	UC	11.7 ± 2.0	125 ± 5	89 ± 9	34 ± 2	235 ± 10	21.8 ± 1.3	79 ± 6
	P	NS	NS	NS	NS	NS	NS	NS
Urgent Surgery	Crohns	14.3 ± 1.7	120 ± 4	81 ± 10	35 ± 1.6	232 ± 15	21.5 ± 2.4	88 ± 5
	UC	14.3 ± 1.7	130 ± 7	87 ± 18	32 ± 2	182 ± 24	19.1 ± 4.0	76 ± 5
	P	NS	NS	NS	NS	NS	NS	NS
Post Surgical Complications	Crohns	17.3 ± 3	114 ± 5	72 ± 22	35 ± 2	180 ± 15	14 ± 1.3	41 ± 9
	UC	16 ± 5	121 ± 5	71 ± 16	31 ± 2	193 ± 15	17.1 ± 3.5	74 ± 10
	P	NS	NS	NS	NS	NS	NS	< 0.05

all data are $\bar{x} \pm \text{SEM}$ Unpaired 't' test.

Elective Group (n = 29)

Pat	Age	Sex	Height	Diag.	Weight	% Wt. Loss	TBF	Predict Protein TBF	TBF Index	Predict Fat TBF	TBF/FFM	RWE	Predict Stress RWE	Albumin Trans.	Pre-alb Grip Index
1	36	M	180	UC	80.7	14	11.95	13.58	0.88	20.2	0.732	1648	1373	145	32.4
2	33	M	175.5	UC	65.2	10.1	11.6	12.5	0.93	10.2	0.72	1309	1302	257	23.7
3	32	F	175.5	UC	83.5	-14	8.7	10.3	0.84	31.5	0.76	1816	1268	254	32.8
4	26	F	157.5	UC	68.3	-12	6.31	7.5	0.84	31.3	0.746	1310	1056	254	32.8
5	32	F	164	Cr	42.9	8	6.49	8.32	0.78	11.69	0.715	1200	1000	242	-
6	32	M	184	UC	76	-5.0	12.35	13.9	0.89	11.24	0.739	2279	1433	245	-
7	32	M	188.5	UC	77	20	12.0	14.3	0.84	12.8	0.744	1317	1431	245	-
8	38	F	163.5	UC	47.8	10	7.6	8.1	0.94	9.1	0.740	1179	1082	257	-
9	33	F	154.5	UC	56.3	0	6.38	7.2	0.87	21	0.747	1213	1036	-	28.6
10	41	F	153	UC	58.7	-1.2	7.1	7.1	1.00	21.8	0.732	1353	1057	-	13.9
11	26	M	187.5	UC	80.5	2.6	15.6	15.0	1.04	10.8	0.728	1722	1537	49.5	30.3
12	35	M	172	UC	62.5	15.5	10.1	12.3	0.82	9.0	0.750	1352	1288	272	31.8
13	30	M	174.5	UC	66.8	-13.2	8.5	9.3	0.91	22.5	0.736	1481	1139	271	33.0
14	14	F	164	UC	52.3	0	8.0	8.51	0.94	14.2	0.722	1728	1080	287	27.2
15	21	M	184	UC	89.2	8	13.8	16.4	0.84	10.8	0.750	2361	1686	239	27.6
16	47	M	169	UC	89.8	0	11.1	14.5	0.77	29.9	0.743	1638	1365	393	25.2
17	24	F	155	UC	53.8	-3.5	8.5	7.2	1.18	14.4	0.72	1248	1023	326	30.9
18	48	F	158.5	UC	55.2	-5	7.0	7.5	0.93	15	0.758	1079	1071	228	27.4
19	22	M	175	UC	64	12	10.9	13.1	0.83	8.0	0.75	1398	1318	-	32.8
20	21	M	176	UC	78.8	1.9	10.2	13.86	0.74	24.6	0.736	1416	1287	320	37.9
21	27	M	179.5	UC	84.3	-2	11.8	14.1	0.84	25	0.737	-	-	275	32.1
22	18	F	164	UC	43.6	5.1	2.54	7.7	0.33	17	0.820	1056	918	278	40
23	39	F	174	UC	80.8	3.8	9.7	14.7	0.71	22.2	0.766	1524	1361	322	37
24	21	F	159	UC	47.7	0	4.71	7.29	0.65	10.6	0.799	1310	1056	198	10.8
25	40	M	169	UC	53.2	0	8.44	9.38	0.9	2.2	0.768	1178	1239	203	15.6
26	31	F	155	UC	60.9	-13.8	6.25	7.17	0.87	21.8	0.767	1348	1083	276	24.5
27	37	F	155	UC	48	-3	4.5	6.4	0.69	17	0.776	-	-	130	18
28	30	M	186	UC	89	0	14.9	14.2	1.05	17.3	0.724	1834	1528	-	-
29	31	M	173.5	UC	75.5	0	10.3	18.5	0.82	18.5	0.753	-	-	-	-
30	31	M	170	UC	67	1.3	9.2	11.0	0.81	17.0	0.748	1465	1231	268	27.7
31	31	M	170	UC	67	1.6	9.2	11.0	0.81	17.0	0.748	1465	1231	268	27.7
32	31	M	170	UC	67	1.6	9.2	11.0	0.81	17.0	0.748	1465	1231	268	27.7
33	31	M	170	UC	67	1.6	9.2	11.0	0.81	17.0	0.748	1465	1231	268	27.7
34	31	M	170	UC	67	1.6	9.2	11.0	0.81	17.0	0.748	1465	1231	268	27.7
35	31	M	170	UC	67	1.6	9.2	11.0	0.81	17.0	0.748	1465	1231	268	27.7
36	31	M	170	UC	67	1.6	9.2	11.0	0.81	17.0	0.748	1465	1231	268	27.7
37	31	M	170	UC	67	1.6	9.2	11.0	0.81	17.0	0.748	1465	1231	268	27.7
38	31	M	170	UC	67	1.6	9.2	11.0	0.81	17.0	0.748	1465	1231	268	27.7
39	31	M	170	UC	67	1.6	9.2	11.0	0.81	17.0	0.748	1465	1231	268	27.7
40	31	M	170	UC	67	1.6	9.2	11.0	0.81	17.0	0.748	1465	1231	268	27.7
41	31	M	170	UC	67	1.6	9.2	11.0	0.81	17.0	0.748	1465	1231	268	27.7
42	31	M	170	UC	67	1.6	9.2	11.0	0.81	17.0	0.748	1465	1231	268	27.7
43	31	M	170	UC	67	1.6	9.2	11.0	0.81	17.0	0.748	1465	1231	268	27.7
44	31	M	170	UC	67	1.6	9.2	11.0	0.81	17.0	0.748	1465	1231	268	27.7
45	31	M	170	UC	67	1.6	9.2	11.0	0.81	17.0	0.748	1465	1231	268	27.7
46	31	M	170	UC	67	1.6	9.2	11.0	0.81	17.0	0.748	1465	1231	268	27.7
47	31	M	170	UC	67	1.6	9.2	11.0	0.81	17.0	0.748	1465	1231	268	27.7
48	31	M	170	UC	67	1.6	9.2	11.0	0.81	17.0	0.748	1465	1231	268	27.7
49	31	M	170	UC	67	1.6	9.2	11.0	0.81	17.0	0.748	1465	1231	268	27.7
50	31	M	170	UC	67	1.6	9.2	11.0	0.81	17.0	0.748	1465	1231	268	27.7
51	31	M	170	UC	67	1.6	9.2	11.0	0.81	17.0	0.748	1465	1231	268	27.7
52	31	M	170	UC	67	1.6	9.2	11.0	0.81	17.0	0.748	1465	1231	268	27.7
53	31	M	170	UC	67	1.6	9.2	11.0	0.81	17.0	0.748	1465	1231	268	27.7
54	31	M	170	UC	67	1.6	9.2	11.0	0.81	17.0	0.748	1465	1231	268	27.7
55	31	M	170	UC	67	1.6	9.2	11.0	0.81	17.0	0.748	1465	1231	268	27.7
56	31	M	170	UC	67	1.6	9.2	11.0	0.81	17.0	0.748	1465	1231	268	27.7
57	31	M	170	UC	67	1.6	9.2	11.0	0.81	17.0	0.748	1465	1231	268	27.7
58	31	M	170	UC	67	1.6	9.2	11.0	0.81	17.0	0.748	1465	1231	268	27.7
59	31	M	170	UC	67	1.6	9.2	11.0	0.81	17.0	0.748	1465	1231	268	27.7
60	31	M	170	UC	67	1.6	9.2	11.0	0.81	17.0	0.748	1465	1231	268	27.7
61	31	M	170	UC	67	1.6	9.2	11.0	0.81	17.0	0.748	1465	1231	268	27.7
62	31	M	170	UC	67	1.6	9.2	11.0	0.81	17.0	0.748	1465	1231	268	27.7
63	31	M	170	UC	67	1.6	9.2	11.0	0.81	17.0	0.748	1465	1231	268	27.7
64	31	M	170	UC	67	1.6	9.2	11.0	0.81	17.0	0.748	1465	1231	268	27.7
65	31	M	170	UC	67	1.6	9.2	11.0	0.81	17.0	0.748	1465	1231	268	27.7
66	31	M	170	UC	67	1.6	9.2	11.0	0.81	17.0	0.748	1465	1231	268	27.7
67	31	M	170	UC	67	1.6	9.2	11.0	0.81	17.0	0.748	1465	1231	268	27.7
68	31	M	170	UC	67	1.6	9.2	11.0	0.81	17.0	0.748	1465	1231	268	27.7
69	31	M	170	UC	67	1.6	9.2	11.0	0.81	17.0	0.748	1465	1231	268	27.7
70	31	M	170	UC	67	1.6	9.2	11.0	0.81	17.0	0.748	1465	1231	268	27.7
71	31	M	170	UC	67	1.6	9.2	11.0	0.81	17.0	0.748	1465	1231	268	27.7
72	31	M	170	UC	67	1.6	9.2	11.0	0.81	17.0	0.748	1465	1231	268	27.7
73	31	M	170	UC	67	1.6	9.2	11.0	0.81	17.0	0.748	1465	1231	268	27.7
74	31	M	170	UC	67	1.6	9.2	11.0	0.81	17.0	0.748	1465	1231	268	27.7
75	31	M	170	UC	67	1.6	9.2	11.0	0.81	17.0	0.748	1465	1231	268	27.7
76	31	M	170	UC	67	1.6	9.2	11.0	0.81	17.0	0.748	1465	1231	268	27.7
77	31	M	170	UC	67	1.6	9.2	11.0	0.81	17.0	0.748	1465	1231	268	27.7
78	31	M	170	UC	67	1.6	9.2	11.0	0.81	17.0	0.748	1465	1231	268	27.7
79	31	M	170	UC	67	1.6	9.2	11.0	0.81	17.0	0.748	1465	1231	268	27.7
80	31	M	170	UC	67	1.6	9.2	11.0	0.81	17.0	0.748	1465	1231	268	27.7
81	31	M	170	UC	67	1.6	9.2	11.0	0.81	17.0	0.748	1465	1231	268	27.7
82	31	M	170	UC	67	1.6	9.2	11.0	0.81	17.0	0.748	1465	1231	268	27.7
83	31	M	170	UC	67	1.6	9.2	11.0	0.81	17.0	0.748	1465	1231	268	27.7
84	31	M	170	UC	67	1.6	9.2	11.0	0.81	17.0	0.748	1465	1231	268	27.7
85	31	M	170	UC	67	1.6	9.2	11.0	0.81	17.0	0.748	1465	1231	268	27.7
86	31	M	170	UC	67	1.6	9.2	11.0	0.81	17.0	0.748	1465	1231	268	27.7
87	31	M	170	UC	67	1.6	9.2	11.0	0.81	17.0	0.748	1465	1231	268	27.7
88	31	M	170	UC	67	1.6	9.2	11.0	0.81	17.0	0.748	1465	1231	268	27.7
89	31	M	170	UC	67	1.6	9.2	11.0	0.81	17.0	0.748	1465	1231	268	27.7
90	31	M	170	UC	67	1.6	9.2	11.0	0.81	17.0	0.748	1465	1231	268	27.7
91	31	M	170	UC	67	1.6	9.2	11.0	0.81	17.0	0.748	1465	1231	268	27.7
92	31	M	170	UC	67	1.6	9.2	11.0	0.81	17.0					

Remission Group (n=16)

Pat	Age	Sex	Height	Diag	Weight	% Wt Loss	TBF	Predict Protein TBF	TBF	Predict Fat	TBM/FFM	FWE	Predict Stress	Albumin Trans	Pre-alb	Grip				
							Index	Index	Index	Index	Index	Index	Index	Index	Index	Index				
30	50	F	171	Cr	69.8	0	7.51	9.6	0.78	24.8	21.0	1.18	0.752	1459	1167	1.25	36	365	30.8	0.88
31	37	F	173	UC	67	0	8.6	9.6	0.9	16.5	19.44	0.86	0.757	-	-	-	36	225	15.5	0.78
32	26	F	156	Cr	56	0	6.6	7.2	0.92	18.7	14.1	1.33	0.750	1065	1065	1.0	36	248	-	0.77
33	24	F	158	Cr	50.5	-8	6.9	11.2	0.62	13.0	15.8	0.82	0.747	1274	1061	1.2	38	278	-	0.77
34	39	F	152	Cr	36.2	16	5.7	6.5	0.88	7.2	15.5	0.46	0.730	962	1046	0.92	38	-	31.3	0.67
35	20	M	165.5	Cr	53.4	-10	7.9	12.0	0.66	9.2	16.2	0.57	0.752	1287	1100	1.17	-	-	-	0.79
36	17	M	171.5	Cr	50.5	9	7.6	12.9	0.59	12.11	16.36	0.74	0.726	1154	1078	1.07	37	192	37.1	0.79
37	24	M	161.5	Cr	43	2	7.2	11.4	0.63	5.6	16	0.35	0.740	986	1060	0.93	38	211	-	0.69
38	34	F	159	Cr	43.2	3.9	6.7	7.13	0.94	8.8	9.3	0.95	0.729	1132	1022	1.11	-	320	29.5	1.19
39	32	M	172.5	Cr	56.5	3	10.0	12.9	0.78	9.3	16.0	0.58	0.720	1607	1347	1.22	-	263	30.6	0.98
40	24	M	173.5	Cr	63.8	2	11.5	11.7	0.99	7.6	10.4	0.73	0.736	1581	1317	1.2	-	177	33.7	1.0
41	17	F	152	Cr	51.8	0	7.5	6.7	1.12	10.6	11.9	1.4	0.780	1131	1028	1.1	40	332	9	0.76
42	23	M	165	Cr	43.2	-2.8	7.0	8.3	0.85	3.2	1.5	2.1	0.758	1486	1100	1.35	40	263	20	0.59
43	27	M	195	Cr	89	-12	14.2	15.3	0.93	11.4	16.0	0.71	0.754	1840	1614	1.14	-	-	26.6	0.84
44	28	F	161	Cr	63	-9.6	6.51	8.0	0.81	26.6	15.7	1.7	0.761	1265	1054	1.21	-	52.6	30	0.95
45	27	F	164	Cr	55.6	-7	6.9	7.9	0.87	14.0	11.9	1.18	0.770	1531	1117	1.37	39	252	19.6	0.96
29	29	88	166	11	58	-0.8	8	9.9	0.83	12.8	14.2	0.98	0.748	1317	1143	1.15	37.8	281	26	0.84
						+1.8	+0.5	+0.7	+0.2	+1.6	+1.1	+0.12	+0.004	+66	+42	+0.03	+0.5	+25	+2	+0.04

Post Surgical Complications (n=12)

Pat	Age	Sex	Height	Diag	Weight	% Wt Loss	TBP	Predict TBP	TFP	Predict Protein TFP	TFP	Predict Fat TFP	TFP	Predict Fat Index	TBM/FFM	RME	Predict Stress RME	Alb	Alb Index	Trans	Pre-alb	Grip Index																
46	47	F	161	Cr	29.8	28	4.1	6.6	0.62	3.8	7.5	0.51	0.760	831	907	0.92	31	211	12.7	0.23																		
47	38	M	174	UC	71	15	8.7	12.4	0.7	23.2	15.4	1.51	0.760	1523	1199	1.27	-	-	-	0.23																		
48	29	F	155	Cr	46.7	0	5.94	7.0	0.85	11	14.5	0.76	0.777	1317	1037	1.27	-	-	-	-																		
49	20	F	159	UC	45.5	15	4.81	7.76	0.62	10.1	13.8	0.73	0.766	1310	1040	1.26	-	-	-	0.4																		
50	39	M	169	UC	54.7	15	8.6	11.8	0.73	8.4	15.3	0.55	0.734	1511	1180	1.28	-	-	-	1.17																		
51	30	M	168	UC	38.4	23	4.84	12.1	0.4	4.8	15.5	0.31	0.783	1330	1067	1.32	-	-	-	0.31																		
52	22	M	195	Cr	72.4	13	14.7	15.3	0.96	1.2	8.1	0.07	0.734	1628	1521	1.07	37	170	16.7	0.54																		
53	22	F	159	Cr	39.3	28	3.7	7.8	0.48	9.7	14.7	0.67	0.790	1095	960	1.15	38	161	12.7	0.45																		
54	36	F	176	UC	74	7	11.2	13.3	0.84	10.9	16.8	0.65	0.760	2032	1693	1.20	32	234	22	0.9																		
55	41	M	169	UC	46.6	12	6.22	9.3	0.67	8.1	6.3	1.29	0.758	1091	1100	1.01	34	180	10.2	0.9																		
56	22	M	181	UC	50.8	32	8.7	13.5	0.65	6.1	13.4	0.45	0.722	1132	1155	0.98	28	177	19.0	0.54																		
57	24	F	166	Cr	45.5	13	4.1	8.2	0.5	8.5	11.2	0.76	0.816	1262	1060	1.19	34	232	7.8	0.70																		
30.5	+ 9	SA	170	+ 12	SA	51.7	+ 15	SA	16.8	+ 2.7	7.1	+ 0.9	10.4	+ 0.9	0.67	+ 0.95	8.8	+ 1.6	12.7	+ 1.0	0.68	+ 0.12	0.759	+ 0.08	1345	+ 98	1163	+ 72	1.16	+ 0.92	33	+ 1.5	193	+ 10.7	14.4	+ 1.9	0.57	+ 0.11

Urgent Surgery (n=18)

Pat	Age	Sex	Height	Diag	Weight	% Mt Loss	TBP	Predict TBP	TBP Index	TBF	Predict TBF	TBF Index	TBW/FFM	RWE	Predict RWE	RWE Index	Albumin	Trans	Pre-alb	Grip
58	22	F	163	Cr	53.4	15	7.3	8.7	0.84	18.3	18.2	1.0	0.722	1066	1035	1.03	42	260	28.3	0.58
59	19	F	164	Cr	44	12	6.7	8.0	0.84	9.9	10.3	0.96	0.715	1229	1016	1.21	37	-	32.6	0.93
60	48	M	175.5	UC	69.1	5	10.6	11.7	0.91	14.6	13.0	1.12	0.736	1736	1296	1.34	41	234	25.2	0.89
61	74	F	156	UC	76.8	7	5.6	6.82	0.82	30.12	22.0	1.37	0.814	1317	1190	1.11	26	-	21.8	0.75
62	57	M	175	Cr	80.6	2	10.8	12.9	0.84	27.2	18.9	1.44	0.715	1308	934	1.40	35	213	14.3	1.17
63	24	M	172.5	UC	61.8	15	10.1	12.8	0.79	9.8	16.1	0.61	0.737	1666	1262	1.32	-	-	-	0.73
64	52	M	175.5	UC	65.6	21	11.3	13.2	0.86	9.2	19.0	0.48	0.738	1783	1320	1.35	27	163	7.5	0.86
65	57	F	165.5	Cr	43.5	23	5.9	8.0	0.74	8.2	14.9	0.55	0.752	1238	1032	1.20	26	159	19.4	0.38
66	38	M	178.5	Cr	55.1	21	9.9	12.2	0.81	2.8	13.8	0.20	0.742	1444	1309	1.1	33	242	13.4	0.88
67	22	M	172.5	Cr	51.7	16	8.9	11.2	0.80	8.4	8.7	0.96	0.723	1645	1142	1.44	44	227	36.2	0.71
68	24	M	173.5	Cr	56.9	13	10.4	11.7	0.89	5.7	10.4	0.55	0.734	1436	1249	1.15	38	248	24.1	0.94
69	39	M	174.5	UC	51.7	15	7.0	10.7	0.65	13.9	8.7	1.60	0.722	1238	1067	1.16	24	124	23.6	0.48
70	44	F	157	Cr	45.8	15	4.2	7.1	0.60	14.2	15.5	0.91	0.785	1073	984	1.09	37	334	23.9	1.3
71	27	M	165	Cr	58.6	20	8.7	12.1	0.72	7.3	15.6	0.47	0.760	1616	1253	1.29	32	228	16	1.04
72	40	M	170	UC	50.5	38.9	7.6	13.2	0.58	7.3	19.4	0.38	0.745	1855	1151	1.63	36	208	20.5	0.86
73	32	M	186	UC	69.5	20	11.3	14.1	0.80	8.5	15.7	0.54	0.741	1619	1384	1.17	-	-	-	0.59
74	18	M	177	UC	52.2	10	8.0	11.2	0.71	7.9	6.6	1.2	0.752	1220	1099	1.11	30	177	20.4	0.58
75	24	F	166	Cr	45.5	13	4.1	8.2	0.50	8.5	11.2	0.76	0.816	1262	1061	1.19	34	232	7.8	1.1
36 + 16	82		170.5 + 8		57.4 + 11	16.2 + 2	8.1 + 2	10.7 + 0.6	0.75 + 0.03	11.6 + 1.8	14.3 + 1.0	0.82 + 0.09	0.747 + 0.03	1431 + 38	1155 + 31	1.24 + 0.02	33 + 1.5	216 + 14	20.5 + 1.3	0.82 + 0.06

Ileostomy (n=42)

Pat	Age	Sex	Height	Diag	Weight	% Wt Loss	TBF	Predict TBF	TBF Index	Predict Fat TBF	TBF Index	TBW/FFM	RME	Predict RME	Stress Index	Albumin	Trans	Pre-alb	Crip Index
76	57	F	160	Ct	57	0	6.11	7.5	0.81	19.6	0.98	0.754	1232	1208	1.02	34	-	35.5	0.63
77	22	M	180	UC	55.6	8.6	11.5	13.5	0.86	8.6	0.63	0.743	1593	1352	1.18	40	335	13.4	0.97
78	48	F	158.5	UC	48.4	8.3	7.5	7.11	1.05	10.7	0.73	0.729	-	-	-	44	281	32	-
79	27	M	179.5	UC	95	-15	12.5	14.1	0.89	35.3	2.0	0.725	-	-	-	-	266	31.2	-
80	48	M	174	UC	75	10.5	12.6	13.6	0.93	16.0	0.83	0.721	1500	1579	0.95	-	296	34.4	0.95
81	21	M	176	UC	97.1	-20.7	11.44	13.9	0.82	39.2	2.3	0.735	-	-	-	-	-	-	-
82	32	M	174	UC	81.4	0	12.2	12.7	0.96	22.5	1.44	0.733	-	-	-	-	-	-	1.0
83	20	F	159	UC	50.1	-5.0	7.5	7.3	1.03	12.4	1.2	0.733	-	-	-	44	245	23.6	1.0
84	42	M	174	UC	74.1	13.7	11.9	13.7	0.87	19.7	0.97	0.706	-	-	-	-	-	25.5	-
85	39	M	178.5	Ct	69.4	0	10.3	12.9	0.80	13.7	0.89	0.736	-	-	-	-	40	23.8	0.2
86	23	M	176	Ct	59.5	-2.5	10.9	13.25	0.82	8.0	0.5	0.722	1504	1253	1.2	40	258	34.4	0.91
87	42	M	168	UC	68.8	-2.0	9.86	11.19	0.89	17	1.29	0.729	-	-	-	49	-	-	1.0
88	30	M	175	UC	72.0	-6	8.71	10.3	0.85	25	1.20	0.741	-	-	-	46	204	29.7	1.0
89	32	F	159	UC	52	-2	7.04	7.4	0.95	13.3	1.0	0.754	-	-	-	40	249	32.5	-
90	51	F	165	Ct	48.6	14	6.9	7.9	0.87	5.5	0.36	0.772	-	-	-	-	253	25.3	0.70
91	48	F	166	UC	67	2	8.0	8.84	0.90	22.3	1.07	0.749	-	-	-	-	-	24.2	-
92	42	M	174	UC	60.8	-1.5	10.6	10.5	1.0	4.7	0.6	0.725	-	-	-	-	252	26.5	1.0
93	74	F	157	UC	43	0	5.5	7.1	0.78	12.0	0.54	0.727	-	-	-	-	287	28.9	-
94	55	M	170	UC	66.4	0	8.4	11.4	0.74	19.6	1.35	0.739	-	-	-	44	314	31.9	-
95	44	F	161	UC	61.8	-3	7.9	8.9	1.0	19.0	1.1	0.746	-	-	-	-	303	12	-
96	76	F	67	UC	65.8	-	6.5	8.4	0.77	28.1	1.1	0.740	-	-	-	42	205	30.7	-
97	38	F	170	UC	64.4	-4	8.5	9.1	0.93	18.7	1.0	0.743	-	-	-	44.1	231	44	-
98	41	F	157	UC	60	-4	7.4	7.63	0.97	27.1	1.4	0.87	-	-	-	42	299	20.2	-
99	68	M	173	UC	79.5	-	12.4	11.2	1.11	18.4	1.31	0.728	-	-	-	46	405	38.3	-
100	34	M	174	UC	66	-5	10.02	12.5	0.8	11.3	0.73	0.749	1482	1300	1.14	42	278	42.3	1.0
101	48	M	175.5	UC	67	4	10.1	11.7	0.87	12.6	0.96	0.747	1401	1297	1.08	-	-	28.4	1.02
102	42	F	152	UC	54.5	4	6.8	6.5	1.05	17.3	1.08	0.748	1431	1289	1.11	-	-	19.3	1.0
103	33	M	165	UC	51	13	8.8	10.11	0.87	6.5	0.735	-	-	-	-	40	269	31	1.0
104	43	M	186	UC	87.4	-5	13.9	13.8	1.01	21.2	1.39	0.72	-	-	-	45	-	26.8	1.0
105	54	F	159	UC	50.3	0	5.9	6.9	0.85	18.5	1.4	0.723	-	-	-	-	359	29.2	-
106	26	M	187	UC	86.9	-3	17.9	14.4	1.24	11.9	0.74	0.728	-	-	-	-	-	29.3	1.0
107	26	M	172.5	UC	64	-3	11.37	12.6	0.9	10.7	0.68	0.719	-	-	-	-	-	32.5	-
108	47	M	169	UC	89.3	7	11.6	11.6	1.0	28.2	1.76	0.75	-	-	-	-	-	25.9	1.0

Acute Attack (n=53)

Pat	Age	Sex	Height	Diag	Weight	% Mt Loss	TBP	Predict Protein TBP	TBP Index	Predict Fat TBP	TBP Index	TBM/FFM	RWE	Predict Stress RWE	Stress Index	Albumin Trans	Pre-alb	Grip Index		
119	62	M	174	Cr	53.3	12	6.96	11.6	0.6	7.55	5	1.51	0.721	1726	1174	1.47	28	199	16.9	0.69
120	72	M	171	UC	60.6	21.7	9.6	10.9	0.88	4.93	13.5	0.36	0.746	1179	1228	0.96	39	207	34.9	0.65
121	19	M	180	UC	53.0	10	8.73	13.9	0.63	11.17	16.4	0.68	0.714	1379	1121	1.23	34	245	-	0.65
122	26	M	165	Cr	41.2	10	6.33	11.9	0.53	4.67	16.1	0.29	0.754	966	1050	0.92	36	211	-	0.78
123	15	M	158	Cr	31.3	21.8	3.92	7.84	0.50	6.5	1.62	4.0	0.750	1196	892	1.34	31	223	10.4	0.43
124	47	M	179	UC	59.2	19.2	9.34	12.3	0.76	2.9	13.9	0.21	0.769	1871	1318	1.42	27	249	20.3	0.71
125	16	M	158	Cr	35.1	10	5.6	11.3	0.49	2.9	16.3	0.18	0.757	1317	1029	1.28	34	-	14.6	0.43
126	55	F	162	Cr	40.8	10	6.54	7.9	0.83	2.8	19.8	0.14	0.750	1092	1071	1.02	36	-	32	0.82
127	23	M	165	Cr	36.9	12	6.4	8.3	0.77	2.14	1.5	1.4	0.742	1143	1031	1.11	33	173	8.6	0.50
128	16	M	171	Cr	42.2	25.9	6.46	10.8	0.60	4.1	7.2	0.57	0.755	1155	1079	1.01	26	170	11.3	0.44
129	22	M	182	Cr	55.9	20.1	10.0	12.9	0.78	0.9	15	0.06	0.736	1552	1304	1.19	30	207	17.7	0.90
130	36	F	173	UC	55.4	19	6.9	9.8	0.71	15.3	19.6	0.78	0.756	1679	1097	1.53	22	270	21.6	0.46
131	19	M	164	Cr	42.6	11	7.6	9.2	0.83	4.3	4.3	0.94	0.733	1331	1081	1.23	30	286	286	33.8
132	64	M	151	Cr	56.5	6.6	4.0	6.6	0.61	20.9	21.7	0.96	0.787	-	-	-	21	32	5.3	5.3
134	31	F	152	Cr	34.8	17.1	2.31	6.0	0.38	9	9.3	0.97	0.814	998	907	1.1	33	204	18.3	0.83
135	20	F	151	Cr	44.3	5.7	6.3	6.6	0.97	10.3	11.6	0.89	0.743	912	1017	0.90	36	211	20.2	0.59
136	34	F	159.5	Cr	38.7	14	6.6	7.0	0.95	6.4	9.33	0.69	0.724	1020	993	1.03	34	276	11.1	1.4
137	24	F	164	CR	43.3	16.7	6.8	8.0	0.86	8.6	11.7	0.73	0.729	1025	1035	0.99	29	116	7.1	1.08
138	35	F	152	Cr	41.8	5	5.7	6.0	0.9	13.9	9.4	1.48	0.718	906	945	0.96	40	248	30.5	0.54
139	45	F	161	Cr	38.8	24	4.3	7.3	0.60	7	18.4	0.38	0.783	1460	1150	1.27	27	43	6	0.45
140	48	F	171	Cr	67.7	15	7.4	9.6	0.77	21.7	23.3	0.93	0.728	1480	1096	1.35	30	326	44.3	0.59
141	27	F	161	Cr	60.5	-5	6.4	8.1	0.79	22.3	15.7	1.42	0.766	1171	1074	1.09	31	-	31.2	0.84
142	75	F	152	UC	68.5	23	7.8	8.4	0.92	31.4	38.3	0.82	0.714	1120	1058	1.06	-	-	-	0.57
143	23	F	156	Cr	50	9	4.1	7.5	0.55	19.7	15.3	1.29	0.70	1092	966	1.13	43	297	19.8	-
144	21	F	171	Cr	41.6	15	4.6	8.9	0.52	9.3	11.04	0.84	0.791	1338	1045	1.28	34	242	20	0.60
145	43	M	174	Cr	73	0	10.1	12.2	0.83	17	14.9	1.14	0.760	1324	1319	1.0	31	163	169	0.9
146	57	M	182	Cr	58	13	7.2	9.0	0.80	16.2	18.6	0.87	0.737	1444	962	1.5	27	135	15	1.1
147	36	F	162	Cr	40.8	21	6.0	7.7	0.78	5.5	12.6	0.44	0.751	-	-	-	21	113	22	0.9
148	21	F	163	Cr	49.9	27	6.71	9.1	0.74	16.5	21.2	0.78	0.713	-	-	-	35	214	14.9	0.74
149	22	F	165	Cr	47.4	15.4	6.0	8.4	0.71	13	13.7	0.95	0.750	1743	1019	1.71	42	441	54.3	0.59
150	30	F	165	UC	59.5	6.4	6.6	8.03	0.82	26.4	20.5	1.3	0.701	1662	1001	1.66	35	186	19.2	0.79
151	39	M	169	UC	54.7	-1.2	8.6	9.5	0.90	8.4	6.7	1.26	0.726	1489	1183	1.26	43	234	19.4	1.2

**SECTION 4 : THE LONG TERM CHANGES AFTER SURGERY FOR ULCERATIVE
COLITIS**

**CHAPTER 17 : THE LONGITUDINAL CHANGES IN PROTEIN, FAT AND WATER
FOLLOWING J-POUCH FOR ULCERATIVE COLITIS**

Introduction

It has been suggested that patients with well functioning conventional ileostomies for ulcerative colitis have a wide range of body compositional abnormalities. Not only has it been suggested that they remain chronically water and salt depleted (Clarke, et al 1967b) but some investigators believe that as a group these patients remain chronically depleted of nitrogen and body potassium (Turnberg et al 1978), indicating a permanent reduction of the fat free body mass. This is however inconsistent with the clinical appearances of these fully convalescent patients.

In the previous section, the results of my body compositional survey demonstrated normal stores of protein and water after surgery for colitis. There was therefore a necessity to test the validity of these observed changes.

Furthermore, total colectomy with ileoanal J-pouch had been shown to be safe and to provide good functional results (Beck et al 1986) but little was known of the longitudinal changes following this new procedure. Knowledge of the nature and timing of these changes after surgery is not only important to the surgeon but also to the patient. I therefore measured the longitudinal changes in body composition of 21 patients having J-pouches performed for ulcerative colitis (over at least a nine month period following their initial surgery)

Patients and Methods

21 patients who underwent ileoanal J-pouches were studied longitudinally. Their surgery was performed for ulcerative colitis in all cases and the clinical data for this group on initial presentation can be seen in table I. (All raw data for these patients may be found in the at the end of this chapter).

All 21 patients had their surgery performed by Professor Graham Hill and were part of his personal series (Hill 1987).

Entry into this study began at the time of J-pouch formation (day 0). For the majority (n=13) this was their initial surgery for chronic refractory symptoms and steroid dependence or for acute colitis that could be settled down sufficiently by intensive pre-operative medical treatment. For this group their surgery was performed in two stages - stage I (day 0) being total colectomy, mucosal proctectomy J-pouch ileoanal anastomosis together with a temporary ileostomy. Stage II was closure of the temporary ileostomys three months later. Eight patients entered this longitudinal study having already had a previous total colectomy and ileostomy, with preservation of the rectal stump. This operation had been performed on average six months previously

There were three early major post-operative complications. Two patients developed supralelevator pelvic abscesses and one patient developed a superior mesenteric artery syndrome (Christie et al 1988). All three patients required periods of intravenous nutrition.

A further two patients required an initial period of post operative IVN for ileostomy dysfunction. One patient developed

serum hepatitis and two patients developed small bowel obstruction following closure of their loop ileostomies. Four patients were also troubled by episodes of "pouchitis" but in all cases these episodes were brief, responded quickly to a short (one week) course of metronidazole and were not present at the time of the final body compositional evaluation

Study Design

Body compositional measurements were performed on Day 0 - time of J-pouch formation, day 14, 14 days later, and again three months later (day 90) at the time of ileostomy closure.

The final body compositional assessment was made on average 15 months later (range 6 - 34 months) following closure of their temporary ileostomys. At this time all patients included in this series had good function with a mean frequency of bowel movement of 4.3 +/- 1.4 SD stools per day.

Controls

Close matching of patients to controls was achieved for age, sex and height. Controls were recruited, chiefly from either hospital personnel or their friends and family. In all cases the volunteers reported no ill health, were on no medication, and were considered healthy.

Body Composition Measurements

Basic body habitus measurements, including body weight and height were performed.

Body compositional measurements including TBP by IVNAA in

conjunction with measurements of TBW by tritium dilution were performed by standard methods outlined in chapter 5. The FFM was derived by adding TBP + TBW together with the estimate of total body minerals (see chapter 5)

TBK was measured as described in chapter 5, using a whole body shadow shielded counter. This facility was only made available half way through this patient series and hence only 9 patients had serial measurements of TBK.

ECW was measured by bromide dilution. The method and the precision of these measurements are outlined in chapter 5. This measurement of ECW was again only employed half way through this patient series and hence only the later subset of 9 patients had serial measurements of ECW.

Statistical Analysis

Quantitative data of all the patients and controls were compared using a Student's paired 't' test.

Similarly comparison between the patient's sequential measurements were compared with each other using a paired 't' test.

Results

Table I shows the clinical data for the patients and controls.

Patients weighed significantly less on presentation than their controls, with a mean weight loss of 8.5%.

Table II shows the longitudinal changes in body composition following J-pouch formation.

There was a steady significant increase in body weight to control values, with a mean gain of 4.9 +/- 2.2 kg for the group over the study period. This corresponded to a slight overshoot above the patient's remembered well weight.

Protein stores were significantly depleted at the time of J-pouch formation with a further significant loss of 600gm of protein following this surgery.

There was no significant restoration of these protein stores until the final evaluation, many months (mean 15 months, range 6 months - 34 months) following closure of ileostomy.

At this time the average gain in protein for the total group was 1.5 +/- 0.4kg with the majority of patients well on the way to complete restoration.

Apart from losing fat over the time of their major surgery, there was a marked tendency to gain fat during this period, with an average gain of 2.2 +/- 1.4 kg . Patients had normal fat stores on presentation, but had significantly increased fat stores ($p < 0.025$) at the time of final evaluation.

For the subgroup of 9 patients the changes in TBK closely followed the changes in TBP . Significant potassium depletion was found on presentation, with a further loss occurring over the time

of surgery, followed by a slow but steady accumulation in TBK throughout the convalescent period. The changes that occurred in the FFM were similar with a gradual restoration towards a normal control value seen by the time of their final evaluation, with an average gain of 2.5 +/- 1.4kg.

Also shown in table II are the absolute mean changes for TBW and ECW . With the significant increases occurring in the FFM occurring over the same period, it is clearly more appropriate to index these changes to the FFM.

Patients on presentation were significantly over-hydrated with a substantially increased TBW relative to their relatively depleted FFM. TBW was lost over the time of surgery but an abnormal state of hydration existed at the time of ileostomy closure. A normal state of hydration was, achieved by the time of final evaluation. The sequential changes in ECW accounted for most of the measured changes in TBW. The magnitude of the extracellular water expansion (13%), however, on presentation far exceeded the measured increased hydration of the FFM , suggesting that the expanded ECW was associated with a decreased intracellular water volume suggesting intracellular wasting. It is interesting to note that this expansion of ECW persisted until some time following ileostomy closure.

Discussion

The characteristic compositional changes of any wasting disease is a loss of lean cellular tissue and an increasing aqueous phase of body composition (Moore et al 1963). The effect of concomitant steroid administration , in addition to chronic illness, can only lead to a more selective loss of the FFM associated with a relative preservation of fat stores, and a stronger tendency for a greater expansion of the ECW compartment relative to cellular tissue. The body compositional data of the patients on presentation were clearly consistent with this.

The body compositional measurements over the time of surgery confirmed a further loss of protein, together with also a significant loss of body fat. Over this same early post-operative period the patients had also undergone a major reduction of TBW secondary to a significant retraction of the ECW , indicating that the patients had entered the phase of anabolic convalescence.

At the time of temporary ileostomy closure , the majority of the patients had not sustained significant gains in lean tissue, TBK , or TBP. Furthermore, the patients had become, again, significantly overhydrated through a further expansion of the extracellular phase similar to that seen at the time of their initial presentation when the majority of patients were on steroids and suffering from chronic illness.

This indicates that these patients were still suffering from a significant metabolic stress.

Later in this longitudinal study following a rather variable interval from the initial surgery, most patients were approaching

normal body composition. To clarify the timing of this restoration process further, table III shows the same previous body compositional changes for a subset of 16 patients who underwent a more uniform final assessment, all within 320 +/- 90 (SD) days, (range 270 - 450) days following their initial surgery. The changes for this subgroup were similar to that for the whole group and hence within one year of their initial surgery most patients approached normal body composition.

In Figure I the protein stores of each patient at the time of their final assessment (expressed as percentage of their matched control value) were plotted against the time that had elapsed from ileostomy closure.

It was clear that these patients were a heterogenous group, consistent with varying degrees of protein depletion on presentation. Nevertheless there was a significant tendency for an improvement in protein stores to occur with time ($p < 0.05$). Whether this related directly to ileostomy closure or merely the total time interval from their initial surgery is unclear.

This longitudinal series again confirms my previous data. There was no deficit in TBW in the patients pre-operatively or post-operatively, which was contrary to Hill et al 1975 with the Leeds' longitudinal series indicating a persistent deficit of 12%. However in the previous Leeds' study, they predicted normal body water ratios using TBK to predict variations of body water from normality. My methodology fortunately relies on the more sensitive ratio of TBW/FFM. TBW has a precision of +/- 1.5% (SD) and FFM +/- 1.6% (SD) as most of the error again is due to tritium dilution,

since 70% of the FFM is water. (Beddoe et al 1985). I have already demonstrated changes that occur in the ratio: TBW/FFM and hence the difficulty one would encounter relying on predictions of TBW based on TBK (an index of FFM). My results also differ from the results of Cooper et al 1986 and Turnberg et al 1978. I did not demonstrate a severe persisting deficit of the FFM in these fully convalescent patients, rather a gradual restoration towards normality.

This longitudinal data also indicated initial preservation of fat stores with significantly increased fat storage late in the convalescent period. This has not been a consistent finding in the literature. Certainly Cooper et al 1986 found that the amount of TBF in their group of ileostomy patients who had not undergone an ileal resection appeared to be normal. In another study, McNeal et al 1982, showed normal fat stores in a smaller number of ileostomy patients. But in this study, fat stores were assessed by a technique which was prone to considerable errors in such situations (Streat et al 1985).

It could be argued that I have only demonstrated a return towards normal body composition, following J-pouch and the situation may be therefore still different with regard to patients with conventional ileostomies. However, at the time of completing this longitudinal study, the body composition of 14 ileostomy patients, together with their matched controls, was also measured. Their data can be seen in table IV. It was clear that a similar increased fat storage was present in these patients together with no persisting deficit of the FFM. It was furthermore, gratifying

to note that there was a complete restoration of the FFM in this similar patient series who were further convalescent (on average 14 years post operative), than the J-pouch group.

It is certainly gratifying now to be able to inform our young patients presenting for total colectomy for ulcerative colitis, that within one year following surgery they will once again enjoy normal body composition.

This longitudinal study has not only indicated that near complete restoration does occur, after twelve months of convalescence, but the results may also suggest that the defunctionalised stage may in itself cause a number of quite serious metabolic sequelae. Most authors advocate the use of a temporary diverting ileostomy during the period of anastomotic healing. The function and complications associated with temporary ileostomy following this procedure have been previously addressed (Metcalf et al 1986), but there are very few reports addressing the metabolic problems of this defunctionalised stage. My results indicated that patients gained little protein and manifested a state of overhydration to the extent found in serious illness until their ileostomys were closed.

Analysis of the patient body compositional data at time of initial presentation confirms that they had a much eroded FFM associated with a very expanded ECW. This state of overhydration would tend to make them quite intolerant to a high salt load and possibly suggests that a fluid regimen of salt restriction during the early post-operative period would be efficacious to avoid the risk of

further fluid overload. This would make an interesting future study.

Finally I have also demonstrated that this group on presentation , were protein depleted and hence of increased surgical risk. (Windsor et al 1986). For this reason in the presence of a post-operative complication (and these were not uncommon in this present series) one should have a low threshold for nutritional intervention.

I have previously alluded to the improved function following J-pouch over that of conventional ileostomy.. Whether my findings of normal water and salt stores in J-pouch patients relates to the presence of the J-pouch remains yet to be addressed.

I have attempted to answer this question in the next chapter by closely comparing the salt and water metabolism of J-pouch patients to that of conventional ileostomy patients.

LEGENDS FOR TABLES

- Table I Shows the clinical data for the patients and controls
- Table II Shows the longitudinal changes in body composition following J-pouch formation
- Table III Shows body compositional changes for a subset of 16 patients who underwent a more uniform final assessment
- Table IV Shows the body compositional data of 14 ileostomy patients together with their matched controls.

TABLE I**CLINICAL DETAILS OF PATIENTS AND CONTROLS**

	J P *	Controls	P
Number	21	21	
Sex M:F	13:8	13:8	
Age ($\bar{x} \pm$ SD) Yrs	31 \pm 11	33 \pm 9	NS
Range	15 - 52	22 - 50	
Weight ($\bar{x} \pm$ SD) Kg	66 \pm 15	70 \pm 12	P < .05
Range	44 - 89	52 - 97	
Height ($\bar{x} \pm$ SD) cm	171 \pm 9	173 \pm 10	NS
Range	153 - 187	159 - 193	
Pre-op Weight Loss	8.5 \pm 1.5%	-	
Diagnosis Ulcerative Colitis	21	-	

* These measurements refer to patient measurements on day 0.

NS = not significant

paired 't' test

\bar{x} = mean

SD = standard deviation

TABLE II

CHANGES IN BODY COMPOSITION FOLLOWING J-POUCH

	Control	JP Day 0	JP Day 14	JP Day 90	JP Day 540
Body weight (\bar{x} + SEM) KG	70.5 \pm 2.7 -----x----- -----NS----- -----xx-----	66.1 \pm 3.3 -----xxxxx-----	62.1 \pm 3.0 -----xxx-----	65.4 \pm 3.0 -----xxx-----	71.0 \pm 3.8
T _B P (\bar{x} + SEM) KG	11.7 \pm 0.6 -----xxxxx-----	9.2 \pm 0.7 -----xx----- -----xxxx----- -----xxx-----	8.6 \pm 0.7 -----NS-----	8.9 \pm 0.7 -----xxxx-----	10.7 \pm 0.8
T _B F (\bar{x} + SEM) Kg	13.7 \pm 0.8 -----NS-----	15.5 \pm 1.5 -----xx-----	14.0 \pm 1.5 -----NS-----	15.7 \pm 1.2 -----NS-----	17.6 \pm 1.9 -----xx-----
T _B K* (\bar{x} + SEM) mmol	3562 \pm 265 -----xxx-----	3206 \pm 284 -----x----- -----NS----- -----NS-----	2978 \pm 239 -----x-----	3210 \pm 234 -----x-----	3339 \pm 239
F _F M (\bar{x} + SEM) Kg	56.7 \pm 2.5 -----xx-----	50.9 \pm 2.7 -----xxxx----- -----x----- -----xxxx-----	48.1 \pm 2.7 -----xxx-----	50.0 \pm 2.7 -----xxxx-----	53.3 \pm 2.7
T _B W (\bar{x} + SEM) litres	41.7 \pm 1.8 -----xxxx-----	38.2 \pm 2.0 -----xxxxx----- -----NS----- -----xxxx-----	35.2 \pm 1.9 -----xxxxx-----	37.9 \pm 2.0 -----x-----	39.2 \pm 2.0
E _C W* (\bar{x} + SEM) litres	18.9 \pm 1.4 -----x-----	21.7 \pm 1.7 -----x----- -----NS----- -----NS-----	19.5 \pm 1.1 -----NS-----	21.5 \pm 2.4 -----x-----	18.9 \pm 2.0
T _B W/F _F M (\bar{x} + SEM)	0.735 \pm 0.004 -----x-----	0.750 \pm 0.006 -----NS----- -----x----- -----NS-----	0.737 \pm 0.007 -----xxxx-----	0.761 \pm 0.008 -----xxxx-----	0.734 \pm 0.003
E _C W/F _F M (\bar{x} + SEM)	0.31 \pm 0.01 -----xxx-----	0.40 \pm 0.03 -----x----- -----NS----- -----NS----- -----x-----	0.37 \pm 0.02 -----NS-----	0.39 \pm 0.01 -----x-----	0.33 \pm 0.02

x = P < .05 xx = P < .025 xxx = P < .01 xxxx = P < .005 xxxxx = P < .0005

Paired 't' test

* - TBK and ECW were measured sequentially in a subgroup (N=9)

\bar{x} = mean

SEM = standard error of the mean

TABLE III

CHANGES IN BODY COMPOSITION FOLLOW J-POUCH (subset n = 16)

	Control	JP Day 0	JP Day 14	JP Day 90	JP Day 320
Body Weight ($\bar{x} \pm$ SEM) KG	70.8 \pm 3.2	66.6 \pm 3.4	63.05 \pm 3.1	66.4 \pm 3.3	70.8 \pm 4.0
	-----x-----	-----xxxx-----	-----xxx-----	-----xx-----	
		-----xx-----	-----NS-----		
TBP ($\bar{x} \pm$ SEM) KG	11.6 \pm 0.7	9.2 \pm 0.7	8.5 \pm 0.8	9.1 \pm 0.8	10.8 \pm 0.7
	-----xxxxx-----	-----xx-----	-----NS-----	-----xxx-----	
		-----xx-----	-----xxx-----		
TBF ($\bar{x} \pm$ SEM) Kg	13.5 \pm 0.9	17.1 \pm 1.7	15.4 \pm 1.4	16.9 \pm 1.4	18.4 \pm 2.1
	-----x-----	-----xx-----	-----x-----	-----NS-----	
		-----xx-----	-----xx-----		
FFM ($\bar{x} \pm$ SEM) Kg	57.1 \pm 3.1	49.9 \pm 3.0	47.5 \pm 3.0	49.8 \pm 3.2	52.3 \pm 3.0
	-----xxx-----	-----xx-----	-----xxxx-----	-----xx-----	
		-----xx-----	-----xxxx-----		
TBW ($\bar{x} \pm$ SEM) litres	42.0 \pm 2.2	37.2 \pm 2	34.8 \pm 2.5	37.7 \pm 2.4	38.7 \pm 2.2
	-----xxxx-----	-----xxx-----	-----xxxx-----	-----NS-----	
		-----NS-----	-----xxxx-----		
TBW/FFM ($\bar{x} \pm$ SEM)	0.732 \pm 0.005	0.745 \pm 0.006	0.739 \pm 0.008	0.762 \pm 0.01	0.737 \pm 0.004
	-----x-----	-----NS-----	-----xxxx-----	-----xx-----	
		-----NS-----	-----NS-----		
		-----NS-----			

x = P < 0.05 xx = P < 0.025 xxx = P < 0.01 xxxx = P < 0.005 xxxxx = P < 0.0005
 Paired 't' test
 \bar{x} = Mean
 SEM = standard error of the mean

TABLE IV

CLINICAL DETAILS OF ILEOSTOMY PATIENTS
AND CONTROLS

	Ileostomy	Controls	P
Number	14	14	NS
Sex M:F	6:8	6:8	NS
Age (\bar{x} +SD) yrs	44 + 12	45 + 13	NS
range	26 - 76	27 - 66	
Weight (\bar{x} + SD) Kg	63 + 10	68 + 7	NS
range	51 - 87	63 - 76	
Height (\bar{x} + SD) cm	168 + 8	169 + 8	NS
range	156 - 186	157 - 183	
TBP (\bar{x} + SEM) Kg	9.3 + 0.6	10.5 + 0.6	NS
TBF (\bar{x} + SEM) Kg	17.2 + 1.8	15.4 + 1.1	NS
FFM (\bar{x} + SEM) Kg	47.1 + 2.4	51.9 + 1.8	NS
TBK (\bar{x} + SEM) mmol	2963 + 130	3233 + 95	<0.05

NS = not significant

Paired 't' test
 \bar{x} = mean

SD = standard deviation

SEM = standard error of the mean

LEGENDS FOR FIGURE

Fig I. Shows the protein stores of each patient at the time of their final assessment (expressed as a percentage of their matched control value) plotted against the time that had elapsed from ileostomy closure.

FIGURE 1

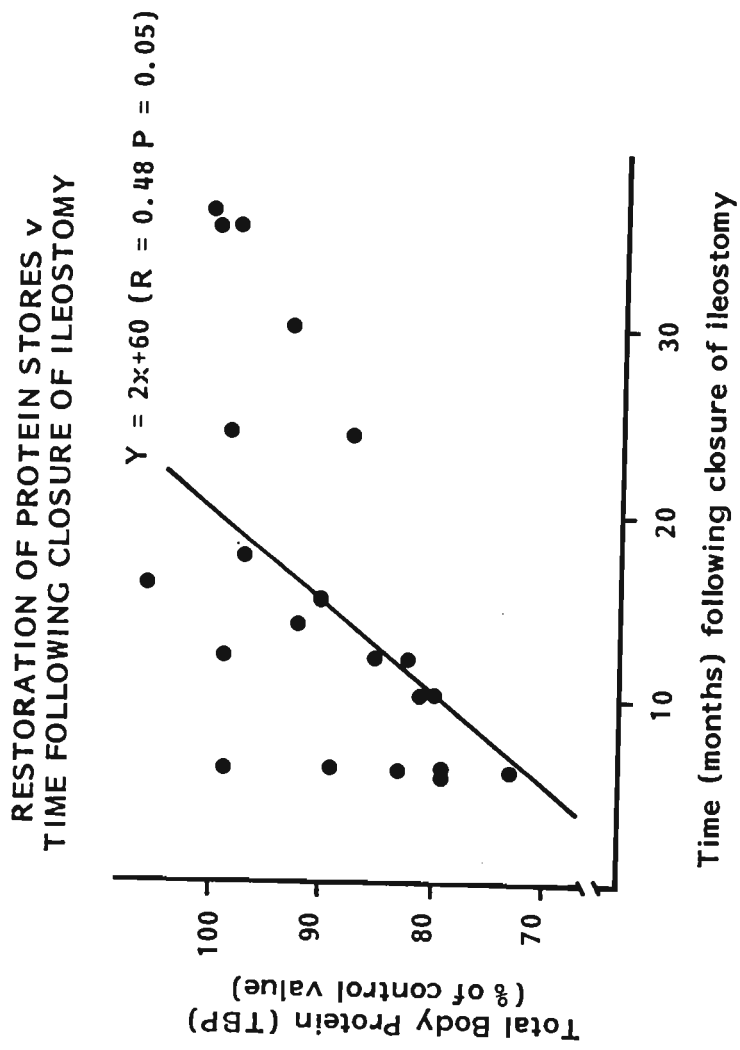

Raw Data J-Pouch Longitudinal Study

Pat	Sex	Age	Ht	Weight			TBW			BW			TBK			TBF			FFM			TBM/FFM			BCM/FFM					
				0	14	360	0	14	360	0	14	360	0	14	360	0	14	360	0	14	360	0	14	360	0	14	360			
1	M	31	173.5	75.5	73.2	78.9	81.2	42.9	40.1	45.6	43.2	10.3	9.4	10.3	12.2	18.5	16.5	19.2	22.5	57	56.7	59.7	58.9	0.730	0.707	0.764	0.734	0.40	0.39	0.38
2	F	31	155.5	60.9	59	58.5	56.6	30	27.9	29.1	29.4	6.3	5.7	7.4	8.0	21.8	29.8	19.2	16.4	39.1	39.4	39.3	40.3	0.767	0.739	0.740	0.732	0.52	0.52	0.52
3	M	21	176	78.9	76.5	77.3	97.1	29.9	37.1	40.3	42.6	10.2	9.2	9.9	11.4	24.6	22.1	25.3	39.1	54.3	54.4	52	57.9	0.735	0.682	0.735	0.735	0.39	0.39	0.39
4	F	20	159	47.7	43.2	46.6	50.1	29.7	26.7	27.6	27.7	4.7	4.7	4.2	7.5	10.6	9.4	12.2	12.4	37.1	33.8	34.4	37.8	0.80	0.730	0.800	0.730	0.39	0.39	0.39
5	F	20	171	45.7	44.7	47.7	57.5	28.8	26.8	29.1	32.6	4.7	4.2	4.5	8.7	9.3	8.4	8.6	7.3	36.5	36.3	39.1	44.1	0.790	0.738	0.744	0.738	0.39	0.39	0.39
6	M	30	186	69.5	63.8	68.1	101	45.2	43.5	45.6	57	11.3	13.6	11	14.6	8.5	2.3	8.7	24.9	61	61.5	59.4	76.1	0.741	0.707	0.768	0.749	0.39	0.39	0.39
7	F	22	164	43.7	41.9	44.5	53.3	21	19.9	22.8	25.9	2.6	2.9	1.0	7.5	16.9	16.7	19	16.8	26.8	25.2	25.5	36.5	0.813	0.790	0.890	0.710	0.39	0.39	0.39
8	M	48	175	61.9	58.5	69.7	67.2	41.3	36.6	41.0	40.9	9.4	8.6	9.4	10.1	12.5	9.7	15.8	12.6	54.4	48.7	53.8	54.7	0.758	0.751	0.761	0.747	0.39	0.39	0.39
9	F	15	164	52.3	50.7	56.7	57.9	27.4	27.5	31.3	31.2	8.0	7.2	6.9	7.4	14.2	12.8	15.8	16.4	38.1	37.9	40.9	41.4	0.721	0.728	0.764	0.754	0.60	0.52	0.37
10	M	42	174	89.3	89.3	79.4	74.1	51.4	39.9	38.4	38.4	13.4	10.7	10.0	11.9	19.7	24	20.3	19.7	69.6	55.4	53.8	54.8	0.739	0.720	0.741	0.706	0.39	0.39	0.39
11	M	26	172	61.8	59.9	66.1	64	38.3	38	38.8	38.3	10.1	9.5	9.8	11.4	9.8	8.8	14.2	10.7	52	51.1	52.4	53.3	0.737	0.744	0.740	0.720	0.39	0.39	0.39
12	M	27	178.8	84.3	76.8	82.6	95	43.7	40.5	44.1	43.7	11.8	12.3	11.5	12.5	25	20.1	25.7	35.3	59.3	56.7	56.9	59.1	0.760	0.748	0.718	0.721	0.39	0.39	0.39
13	M	38	174	80.8	73.1	71.2	75.1	44.9	40	38.7	42.6	8.7	9.5	11.2	12.6	23.2	19.6	17.3	16.0	58.9	40.1	40.3	37.5	0.757	0.708	0.757	0.734	0.39	0.39	0.39
14	F	40	158.5	55.3	53.5	50.1	48.4	30.5	28.4	26.3	27.5	7.0	6.4	6.6	7.5	14.9	13.4	14.9	10.9	40.3	40.1	40.3	37.5	0.764	0.736	0.750	0.750	0.40	0.45	0.40
15	M	52	175.5	69.6	62.5	78.1	80.0	47.8	39.9	47.4	47.9	11.3	10.9	11.4	12.2	6.6	8.3	15.0	16.2	62.4	54.2	63.1	63.8	0.750	0.729	0.779	0.740	0.42	0.35	0.32
16	M	35	172.5	62.5	61.9	61.3	70.5	40.1	36.3	40.5	42.1	10.1	10.1	10.5	11	9.0	12.1	9.3	13.7	53.5	49.8	52	56.3	0.750	0.723	0.727	0.740	0.38	0.36	0.35
17	M	22	182	55.3	50.8	54	68	32.3	32.2	32.4	43.7	9.8	8.7	8.6	11.5	9.6	6.2	9.4	9.4	45.7	44.5	44.6	59	0.706	0.723	0.727	0.740	0.38	0.36	0.35
18	F	41	153	58.7	56.9	58	54.5	27.04	27.1	28.1	27.8	7.1	7.0	6.4	6.8	21.8	19.6	20.7	17.3	36.9	37.3	37.3	37.2	0.733	0.720	0.753	0.748	0.25	0.24	0.31
19	F	24	155	53.8	49.3	52.8	52	285	25.1	28.9	28.2	8.5	3.2	8.3	6.7	14.3	18.6	14.7	14.6	39.6	30.7	37.3	37.4	0.720	0.817	0.774	0.755	0.39	0.39	0.39
20	M	47	187.5	82.8	80.5	83.1	86.9	52.5	55.5	58.2	54.6	15.6	14.3	13.7	17.9	16.7	6.4	6.2	11.9	72.1	74.1	76.9	75	0.728	0.752	0.757	0.710	0.36	0.32	0.44
21	M	47	169	89.8	82.5	86.5	89.3	44.5	43.1	47.9	47.5	11.2	9.9	12.0	11.5	30.0	25.2	27.4	26.1	59.9	57.2	64.1	63.1	0.743	0.754	0.746	0.750	0.35	0.35	0.36
Controls																														
1	M	31	178	70.8	73.2	78.9	81.2	42.9	40.1	45.6	43.2	11.4	9.4	10.3	12.2	18.5	16.5	19.2	22.5	57	56.7	59.7	58.9	0.730	0.707	0.764	0.734	0.39	0.39	0.39
2	F	22	159	54.7	54.7	54.7	54.7	27.9	27.9	29.1	29.4	9.4	9.4	9.4	8.0	21.8	29.8	19.2	16.4	39.1	39.4	39.3	40.3	0.728	0.728	0.728	0.728	0.39	0.39	0.39
3	F	24	163	52.3	52.3	52.3	52.3	27.9	27.9	29.1	29.4	12.6	12.6	12.6	11.4	24.6	22.1	25.3	39.1	54.3	54.4	52	57.9	0.722	0.722	0.722	0.722	0.39	0.39	0.39
4	F	26	171	64	64	64	64	26.7	26.7	27.6	27.7	9.2	9.2	9.2	8.2	16.7	16.7	16.7	16.7	60.8	60.8	60.8	60.8	0.732	0.732	0.732	0.732	0.39	0.39	0.39
5	F	26	171	64	64	64	64	26.7	26.7	27.6	27.7	15	15	15	15	15	15	15	15	48.3	48.3	48.3	48.3	0.735	0.735	0.735	0.735	0.39	0.39	0.39
6	M	30	184	84.5	84.5	84.5	84.5	48.6	48.6	48.6	48.6	14.9	14.9	14.9	14.9	14.9	14.9	14.9	14.9	67.7	67.7	67.7	67.7	0.718	0.718	0.718	0.718	0.39	0.39	0.39
7	F	25	160	52	52	52	52	32.5	32.5	32.5	32.5	9.4	9.4	9.4	8.2	8.2	8.2	8.2	8.2	45.1	45.1	45.1	45.1	0.732	0.732	0.732	0.732	0.39	0.39	0.39
8	M	40	177	76.4	76.4	76.4	76.4	45.5	45.5	45.5	45.5	12.8	12.8	12.8	15.0	15.0	15.0	15.0	15.0	61.5	61.5	61.5	61.5	0.740	0.740	0.740	0.740	0.39	0.39	0.39
9	F	22	160	55	55	55	55	33.7	33.7	33.7	33.7	12.7	12.7	12.7	10.8	10.8	10.8	10.8	10.8	43.9	43.9	43.9	43.9	0.768	0.768	0.768	0.768	0.39	0.39	0.39
10	M	40	175	76.3	76.3	76.3	76.3	45.5	45.5	45.5	45.5	15.4	15.4	15.4	15.4	15.4	15.4	15.4	15.4	61.5	61.5	61.5	61.5	0.740	0.740	0.740	0.740	0.39	0.39	0.39
11	M	31	178	71.2	71.2	71.2	71.2	39.0	39.0	39.0	39.0	11.6	11.6	11.6	16	16	16	16	16	54.4	54.4	54.4	54.4	0.728	0.728	0.728	0.728	0.39	0.39	0.39
12	M	35	180	77.2	77.2	77.2	77.2	43.8	43.8	43.8	43.8	12.6	12.6	12.6	16.3	16.3	16.3	16.3	16.3	59.8	59.8	59.8	59.8	0.720	0.720	0.720	0.720	0.39	0.39	0.39
13	M	40	176	76.4	76.4	76.4	76.4	46.2	46.2	46.2	46.2	12.6	12.6	12.6	15.0	15.0	15.0	15.0	15.0	61.5	61.5	61.5	61.5	0.742	0.742	0.742	0.742	0.39	0.39	0.39
14	F	46	162	67	67	67	67	33.7	33.7	33.7	33.7	9.3	9.3	9.3	17.9	17.9	17.9	17.9	17.9	45.0	45.0	45.0	45.0	0.747	0.747	0.747	0.747	0.39	0.39	0.39
15	M	50	176	87.5	87.5	87.5	87.5	59.1	59.1	59.1	59.1	12.8	12.8	12.8	11.0	11.0	11.0	11.0	11.0	76.5	76.5	76.5	76.5	0.770	0.770	0.770	0.770	0.39	0.39	0.39
16	M	32	179	70.8	70.8	70.8	70.8	39.9	39.9	39.9	39.9	11.6	11.6	11.6	17	17	17	17	17	54.8	54.8	54.8	54.8	0.728	0.728	0.728	0.728	0.39	0.39	0.39
17	M	30	183	84	84	84	84	48.6	48.6	48.6	48.6	14.6	14.6	14.6	17	17	17	17	17	67.0	67.0	67.0	67.0	0.718	0.718	0.718	0.718	0.39	0.39	0.39
18	F	46	160	66	66	66	66	33.7	33.7	33.7	33.7	9.3	9.3	9.3	18.2	18.2	18.2	18.2	18.2	47.8	47.8	47.8	47.8	0.705	0.705	0.705	0.705	0.39	0.39	0.39
19	F	21	159	54.9	54.9	54.9	54.9	34.2	34.2	34.2	34.2	7.3	7.3	7.3	10.7	10.7	10.7	10.7	10.7	43.9	43.9	43.9	43.9	0.768	0.768	0.768	0.768	0.39	0.39	0.39
20	M	24	193	97	97	97	97	63.0	63.0	63.0	63.0	18.5	18.5	18.5	10.7	10.7	10.7	10.7	10.7	86.3	86.3	86.3	86.3	0.730	0.730	0.730	0.730	0.39	0.39	0.39
21	M	50	169	65	65	65	65	43.2	43.2	43.2	43.2	11.4	11.4	11.4	18.3	18.3	18.3	18.3	18.3	57.9	57.9	57.9	57.9	0.746	0.746	0.746	0.746	0.39	0.39	0.39

**CHAPTER 18 : METABOLISM OF BODY WATER AND ELECTROLYTES AFTER
SURGERY FOR ULCERATIVE COLITIS - ILEOSTOMY VERSUS J-POUCH**

Introduction

Some authorities believe that patients with conventional ileostomies are chronically water and salt depleted. (Clarke et al 1967b) although this has recently been questioned (Cooper et al 1986, Turnberg et al 1978).

My recent longitudinal study presented in Chapter 17, on patients following J-pouch had suggested normal stores of water and salt. The situation with ileostomy had to be clarified. It would also be very interesting to examine whether the presence of a well functioning J-pouch conferred advantage in terms of water and salt metabolism to that following conventional ileostomy.

Patients and Methods

Patients All patients in the study had surgery for ulcerative colitis. Fourteen patients with well functioning ileostomies (mean output 456 +/- 46 SD g per day) together with twenty patients with well functioning J-pouches (mean frequency of bowel movement 4.3 +/- 1.4 SD per day) were studied as outpatients together with their closely matched control groups. The ileostomy patients had had their procedure on average 14 years (range 1.5 - 30 yrs) previously. The 20 J-pouch patients were all part of Professor Graham Hill's personal series (Hill, 1987), and

their loop ileostomies had been closed on average 18 months (range 6 - 40 months) prior to this study. None of my patients had undergone a significant small bowel resection.

Controls

To allow close matching of the two patient groups for age, sex, weight and height, two separate control groups were recruited. Normal volunteers were mainly recruited from either hospital personnel or their friends and families. In all cases the volunteers reported no ill health, were on no medication and were considered healthy.

Body Composition

Basic body habitus measurements including body weight and height were performed.

Body composition measurements were carried out by techniques outlined in Chapter 5. In particular TBP was derived by IVNAA in conjunction with measurements of TBW by tritium dilution. The FFM was derived by adding TBP and TBW together with the estimate of total body minerals and glycogen. The ECW was measured by bromide dilution, as described in chapter 5.

Urine and stool analysis

All patients and controls underwent 48 hour collections of urine for volume and sodium and potassium content, as outlined in Chapter 8.

Statistical analysis

Quantitative data of the patient and control groups were compared using Student's 't' test. The fluid spaces were plotted against FFM and the results were compared by linear regression analysis.

RESULTS

Table I shows the clinical details of the two patient groups and their respective control groups. The controls for the ileostomy group and the J-pouch group were closely matched for age, sex, height and weight. In figures I and II, TBW was plotted against the FFM for ileostomy patients and the J-pouch patients respectively. These plots were compared with those of their control groups. It can be seen that the regression lines were almost identical for the patients and controls suggesting that chronic dehydration was not present in either patient group.

In our laboratory we have previously shown that the normal hydration coefficient of the FFM was $72.6 \pm 1.5\%$ (SD) for females and $71.1 \pm 1.2\%$ (SD) for males (Beddoe et al 1985). In this present series the average hydration coefficient for all the female controls was $74.1 \pm 2.5\%$ (SD) and for the male controls was $72.7 \pm 2.5\%$ (SD). These values were not significantly different from the normal data. In figures III and IV, ECW is plotted against FFM for the ileostomy patients and J-pouch patients respectively and these plots were compared with those of their control groups. It can be seen that the regression lines were similar for each patient group and their control group, suggesting that ileostomy patients and J-pouch patients were not depleted of ECW.

The results of the 24 average hour faecal volume and 24 hour faecal excretion of sodium and potassium are shown in table II together with the results of the average 24 hour urine volume and 24 hour urine excretion of sodium and potassium in the two patient groups and the control group.

It can be seen that there was no significant difference in either the volume of stool or the electrolyte content of the stool between the ileostomy and J-pouch patients. In this regard it is interesting to note that none of the ileostomy patients were on any medication to manipulate bowel function, whereas 40% of the J-pouch patients were taking Loperamide (average dose 8mg/day).

Furthermore there was no difference in the weight of faecal effluent between those J-pouch patients on medication and those that were not, when the weight of effluent was indexed to their body weight.

DISCUSSION

There was no evidence in this study that patients with either conventional ileostomy or ileoanal J-pouch were chronically water or salt depleted. Although the faecal outputs of water and sodium were similar after these procedures they were 2-3 times higher than those of normal subjects. For this reason urinary conservation of water and sodium was to be expected but clearly the patients were compensating well and there were no whole body deficits.

These results were somewhat different to those described by Clarke et al, 1967b who interpreted their findings in a group of patients with well functioning ileostomies as showing a deficit of total body water as well as a deficit of total exchangeable sodium. Their findings based on body weight rather than the FFM however, could be explained if their ileostomy patients had greater fat stores than their closely matched controls.

I have tested this hypothesis in my patient series by measuring the fat stores (ie. percent of body weight that was fat) directly in both the patient groups and the controls. Both ileostomy and J-pouch patients had significantly increased fat stores compared with their controls: 27.3 +/- 2.3% (SE) ileostomy v 22.4 +/- 1.5% (SE) controls (P<.05) and 26.0 +/- 1.7% (SE) J-pouch v. 19.9 +/- 1.0 (SE) in controls (P<.005). Furthermore if I plot my own ileostomy data against body weight (fig V) as was done by Clarke et al, I also show erroneously a similar deficit in total body water of 9%.

On the other hand my results were in agreement with more recent

work particularly that of Cooper et al (1986) and Turnberg and his colleagues (1978) . With regard to my finding of increased fat stores, this has not been a constant finding in the literature and certainly Cooper et al, 1986 found that the amount of TBF in their group of ileostomy patients, who had not undergone an ileal resection, appeared to be normal.

In another study (McNeil et al 1982) showed normal fat stores in a small number of ileostomy patients but as mentioned previously these were assessed by a technique which was prone to considerable errors in such situations (Streat et al 1985).

Finally, it is important to stress that despite having demonstrated normal body stores of water and salt in my patients after conventional ileostomy and also after the new operation of ileoanal J-pouch, these patients depend on renal conservation mechanisms to compensate for their obligate faecal losses of salt and water. These compensatory mechanisms known to increase the incidence of renal calculi in ileostomy patients (Bambach et al 1981) will probably result in similar problems in patients after ileoanal anastomosis with J-pouch. This question is an important one, and may not however relate only to the relative degree of renal conservation of salt and water. Little is known of the uric acid and oxalate metabolism, following J-pouch . Clearly the relative risks of renal calculi formation in this group of young patients remains an urgent task. This very question will be examined in the following chapter

LEGENDS FOR TABLES

Table I Shows the clinical details of the two patient groups
and their respective control groups.

Table II Shows the 24 hour faecal and urine analysis

TABLE I**CLINICAL DETAILS OF STUDY GROUPS**

	Control	Ileostomy	Control	J Pouch
	n = 14	n = 14	n = 20	n = 20
Sex	6M 8F	6M 8F	11M 9F	11M 9F
Age ($\bar{x} \pm$ sd) yrs	45 \pm 13	44 \pm 12	35 \pm 11	33 \pm 11
Range yrs	27 - 66	26 - 76	22 - 60	16 - 53
Body Weight				
($\bar{x} \pm$ sd) kg	68 \pm 7	63 \pm 10	71 \pm 11	68 \pm 7
Range kg	63 - 76	51 - 87	52 - 97	41 - 101
Height				
($\bar{x} \pm$ sd) cm	169 \pm 8	168 \pm 8	174 \pm 9	169 \pm 10
Range cm	157 - 183	156 - 186	159 - 193	153 - 186

TABLE II

24 HOUR FAECAL AND URINARY ANALYSIS

	Stool 24 hours			Urine 24 hrs	
	Wt (g)	Na (mmol)	K (mmol)	Vol (ml)	Na:K
Control	-	-	-	1554 ± 1	2.10 ± 0.30
Ileostomy	548 ± 40	74 ± 10	14 ± 5	1171 ± 130	0.96 ± .15
J-Pouch	507 ± 49	58 ± 10	8 ± 1	1139 ± 95	1.17 ± .13
P ₁₋₂	-	-	-	ns	<.005
P ₁₋₃	-	-	-	ns	<.01
P ₂₋₃	ns	ns	ns	ns	ns

Shown mean ± SE Unpaired Students 't' test.

LEGENDS FOR FIGURES

Figure I

Relationships between total body water and fat free mass in ileostomy patients and their controls.

Figure II.

Relationships between total body water and fat free mass for J-Pouch patients and their controls.

Figure III

Relationships between total extracellular water and fat free mass for ileostomy patients and their controls

Figure I V

Relationships between total extracellular water and fat free mass for J-pouch patients and their controls.

Figure V

Relationships between total body water and body weight for ileostomy patients and their controls.

FIGURE I

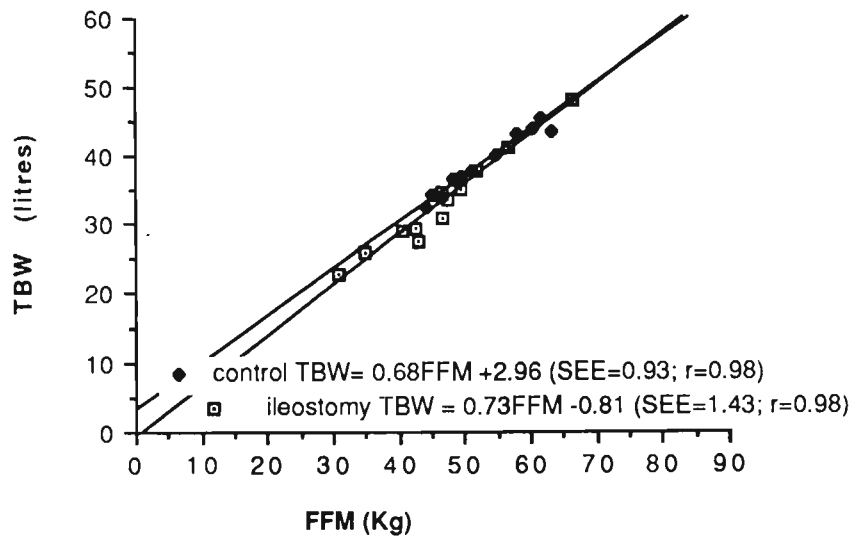

FIGURE II

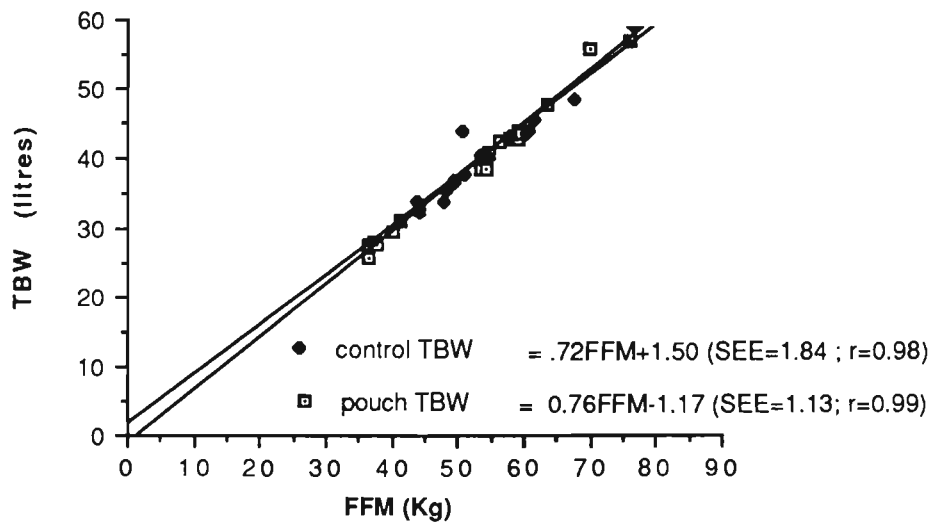

FIGURE III

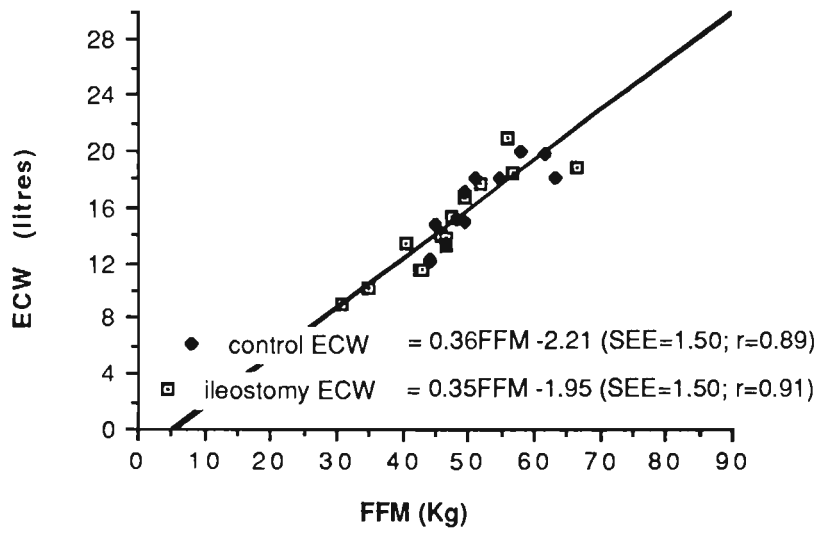
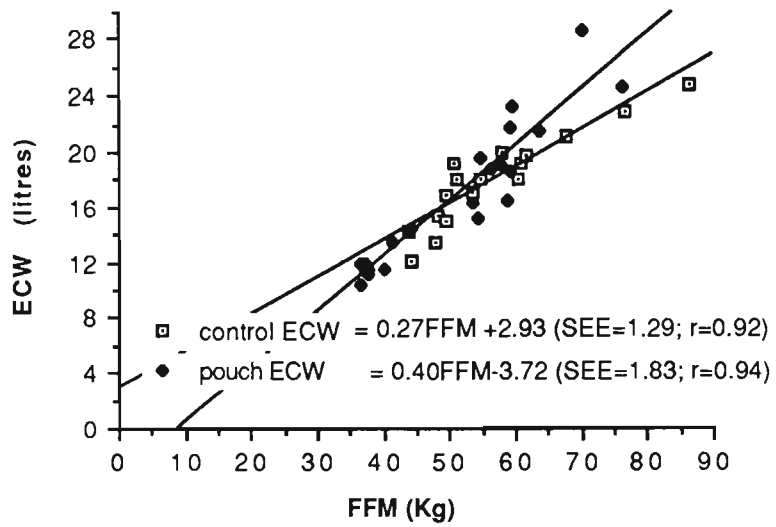

FIGURE IV



ILEUSIOMY PATIENTS

Pat	Sex	Age Yr	Ht Cm	Body composition				Urine				Faecal							
				TBK mol	TBP Kg	Fat Kg	Fat/wCZ	TBW L	FFM Kg	TBW/FFM	ECF L	24 Hr Volml	Na mol	K	Na:K	Wt gm	Na mol	K	Na:k
1	F	32	72	3102	11.18	25.01	34.7	34.8	47.0	0.740	16.8	1587	38.7	80	0.48	794	94	10.5	9.4
2	M	42	60.8	3055	10.57	3.7	7.7	40.7	56.1	0.725	20.9	1777	36.0	76.4	0.47	710	84.7	6.9	12.2
3	M	55	66.4	3096	8.42	19.6	29.5	34.6	46.8	0.739	13.9	1788	88	79.6	1.11	676			
4	F	33	52	2414	7.04	13.4	25.5	29.0	38.6	0.750	13.4	610	78	67	1.16	395			
5	F	44	61.8	2831	7.86	19.0	30.6	27.5	42.8	0.740	11.6	1304	39	50.1	0.7	439	59	50.1	0.72
6	F	38	54.6	2978	8.54	18.7	29.6	34.1	45.9	0.740	14.1	710	87.5	62.1	1.41	563	64	5.2	12.3
7	M	43	87.4	4134	13.9	21.0	24.0	47.9	66.4	0.720	18.9	790	118	218	0.51	517	80	7.2	11.1
8	F	7668.7	167	2885	6.54	26.0	32.9	29.4	42.6	0.690	11.5	1347	92	53	1.71	479	54	6.2	8.7
9	F	61	60	2593	5.92	25.2	42	25.8	34.8	0.740	10.1	955	76	64	1.18	352	52	4.1	12.6
10	F	74	43	2001	5.52	12.0	28	22.5	31	0.730	9.1	1110	37	49.4	0.75	330	90	4.51	20
11	M	34	66.0	3145	10.02	11.3	17.1	41.0	54.7	0.750	18.4	1900	93	39.9	2.3	762	84	8.0	10.5
12	M	26	51	2452	8.86	6.4	12.7	30.7	44.5	0.690	13.3	1460	61.6	74.5	0.82	438			
13	F	46	67	2861	10.3	-	-	33.5	44.6	0.750	15.4	550	9.9	66	0.15	613			
14	M	43	68.8	3096	9.96	22.3	33	37.8	51.8	0.730	17.7	510	50	66	0.75	600			

FOUCH PATIENTS

Pat	Sex	Age	Yr	Wt	Ht	Body composition						Urine						Faecal								
						TKG	TDP	Fat	Fat/	TBW	FFM	TBM/	ECF	24 Hr	Na	K	Na:K	Wt	Na	K	Na:K					
				Kg	cm	mol	Kg	Kg	wt%	L	Kg	L	L	Volml	mmol	mmol	mmol	mmol	gm	mmol	mmol	mmol	gm	mmol	mmol	mmol
1	M	32	81.4	174	4009	12.24	22.5	12.7	43.2	58.59	0.734	16.6	1080	107	101	1.06	629	42.0	7.3	5.8						
2	M	28	95	179.5	4564	12.54	30.3	37.2	43.27	64.7	0.725	23.3	810	162	73	2.2	573	70.2	9.6	7.3						
3	M	23	97.1	178	4369	11.44	39.2	40.4	42.55	57.93	0.720	19.1	800	99	43	2.3	236	57.9	8.2	7.1						
4	M	44	74.1	174	3489	11.94	19.7	26.6	38.37	54.38	0.706	15.2	585	60	65.6	0.91	555	47.5	4.5	10.6						
5	F	20	53.3	165	2441	7.51	16.8	31.5	25.93	36.50	0.730	10.3	580	48	47.6	1.01	387	42.5	5.3	8.1						
6	M	39	75.1	174	3617	12.6	16.1	21.4	42.6	59.0	0.721	18.6	1375	87.5	63.3	1.38	455	35.3	4.5	7.8						
7	F	23	50.11	158.5	2472	7.55	12.3	24.7	27.68	37.75	0.733	11.2	1649	38.5	50.6	0.76	357	102	14.6	7.0						
8	M	32	101	186	4835	14.59	24.9	24.7	57.0	76.1	0.750	24.7	1850	157	168	0.93	1186	101	17	6.0						
9	F	21	51.5	171	2521	8.7	7.34	14.2	32.6	44.16	0.730	14.4	600	99	84.7	1.17	454	58	8	7.2						
10	M	22	64	172.5	3102	11.37	10.7	16.8	38.34	53.65	0.720	16.4	1105	19	57.7	0.33	169									
11	F	31	56.6	155	2623	8.04	16.3	28.9	29.45	40.25	0.730	11.6	720	37	63	0.50	509									
12	F	46	48.4	157.5	2323	7.47	10.9	22.5	27.52	37.51	0.730	11.6	1187	36	51	0.70	455	35	6	5.8						
13	F	50	56.3	159	2398	6.74	17.9	31.7	27.7	36.33	0.760	11.9	1370	77	68	1.13	498									
14	M	48	67.2	175	3063	10.09	20.0	30	40.85	54.65	0.747	19.7	840	20	62	0.32	400	36	4.5	8						
15	F	16	57.9	164	2589	7.42	16.5	28.4	31.24	41.45	0.754	13.4	1750	152	111	1.37	7600									
16	M	23	68.4	182	3267	11.49	9.4	13.7	43.66	59	0.740	18.8	1350	150	77	1.94	550									
17	M	36	70.5	172	3386	11.0	13.7	19.4	42.52	56.34	0.740	18.8	1000	100	74	1.35	590									
18	M	53	80	175	3885	12.16	16.19	20.2	47.86	63.8	0.750	21.6	1750	154	133	1.16	540									
19	F	41	58	153	2558	7.79	17.3	29.8	27.81	41.0		11.36	800	-	-	-	540									
20	F	24	52	155	2346	6.7	11	28	28.22	37.38	0.755	12.0	1250	95	56	1.7	-									

ILEOSTOMY CONTROL

Cont	Sex	Age Yr	Ht cm	Body composition							Urine				
				TKM mmol	TBP Kg	Fat Kg	Fat wt%	TBM L	FFM Kg	TBM/FFM	ECF L	24 Hr Volml	Na mmol	K	Na:k
1	F	24	52.3	2658	9.22	8.2	15.7	32.23	44.06	0.730	12.1	1320	134	49	2.73
2	M	40	76.45	3727	12.76	15.0	19.6	45.49	61.48	0.740	19.8	1360	152	123	1.23
3	M	59	78	3604	15.47	14.9	19.8	43.59	63.11	0.690	18.08	1800	155	162	2.5
4	F	27	60.4	2857	9.53	11.1	18.4	36.38	49.3	0.740	15.04	1700	155	82	1.9
5	F	44	64	2966	9.29	16	25.0	33.66	46.76	0.720	13.5	1600	142	52	2.7
6	F	39	65.3	2949	8.76	13.9	21.3	37.10	49.33	0.750	17.04	1350	123	42	2.9
7	M	36	77.5	3735	12.6	16.7	21.5	43.85	60.5	0.720	19.2	1320	134	91	1.47
8	F	66	63.2	2770	7.47	18.0	28.5	34.41	45.20	0.760	14.9	1700	150	70	2.1
9	F	62	69	2935	8.61	18.6	26.9	36.38	48.37	0.750	15.1	1600	50	34	1.47
10	F	50	69	3289	8.62	24	34.8	32.35	44.13	0.730	12.4	1400	146	52	1.98
11	M	65	66.2	3219	11.38	8.3	12.5	43.25	57.88	0.750	20	1460	138	49	1.94
12	M	31	70.8	3484	11.38	15.9	22.5	39.89	54.84	0.720	18.0	1660	149	79	1.89
13	F	46	67.6	3002	10.01	16.5	24.4	37.62	51.1	0.740	18	-	-	-	-
14	M	38	74	3740	12.60	15.0	20.2	45.49	61.48	0.740	19.8	1700	152	123	3.2

POUCH CONTROLS

Cont	Sex	Age yr	Wt kg	Ht cm	TBK mmol	TBP kg	Fat kg	Fat/ wt%	TBW (L)	FFM kg	TBW/ FFM	ECF (L)	Urine			Na:K
													24 hr Vol ml	Na	K mmol	
1	M	31	70.8	178	3484	11.38	15.96	22.5	39.89	54.84	0.720	18.0	1660	149	79	1.89
2	M	40	76.45	176.5	3727	12.76	14.97	19.5	45.49	61.48	0.740	19.8	1360	152	123	1.23
3	F	24	52.3	163.9	2658	9.22	8.24	15.8	32.31	44.06	0.730	12.1				
4	M	36	77.5	181	3725	12.63	16.7	21.5	43.85	60.8	0.720	19.2				
5	F	26	64	171	2922	8.97	15.7	24.5	35.47	48.26	0.730	15.4	1320	134	91	1.47
6	F	46	67	162	2966	9.29	20.20	30.1	33.66	47.76	0.700	13.5				
7	F	46	67.6	172	3002	10.01	16.5	35.9	37.62	51.1	0.740	18.0				
8	F	31	69	171	3077	9.62	15.46	22.4	40.4	53.54	0.750	17.1				
9	F	22	54.7	159	2412	7.39	10.77	19.6	33.72	43.93	0.770	14.3				
10	M	45	78	183	3604	12.73	17.6	22.6	43.59	60.37	0.720	18.1				
11	M	50	87.5	177	4056	12.75	7.01	8.0	59.12	70.46	0.770	23.0				
12	M	45	78	183	3604	12.73	17.6	22.5	43.59	60.37	0.720	18.1				
13	F	26	60.4	173	2857	9.53	11.08	18.2	36.38	49.3	0.740	15.0				
14	M	31	70.8	178	3484	11.38	15.9	22.4	39.89	54.84	0.720	18.0				
15	M	36	77.5	181	3725	12.63	16.70	21.5	43.85	50.52	0.720	19.2	1660	149	79	1.89
16	M	60	66.2	163	3219	11.38	8.30	12.5	43.25	57.88	0.750	20	1320	134	9.1	1.47
17	F	39	6.53	169	2949	8.76	15.9	24.3	37.1	49.33	0.750	17.0				
18	F	22	54.7	159	24.12	12.73	10.4	19.7	33.7	43.93	0.770	14.3				
19	M	31	84.5	184	4153	14.89	16.77	19.8	48.5	67.8	0.710	21.2				
20	M	30	82.0	181	4060	13.4	15.2	18.5	47.5	66.6	0.710	20.4	1160	138	71	1.94

**CHAPTER 19 : RISK OF URINARY STONE FORMATION FOLLOWING SURGERY FOR
ULCERATIVE COLITIS - ILEOSTOMY VERSUS J-POUCH**

Introduction

Urinary stone formation is a complication of IBD and the surgical management of these conditions (Deren et al, 1962; Maratka et al 1964; Gelzayd et al 1968; Bennett et al 1972). The prevalence of stone formation in ileostomy patients is significant 7-8% (Deren et al, 1962; Maratka et al 1964; Gelzayd 1968) compared with an incidence of 4% in the general population (Scott et al 1977). Uric acid stones usually comprise less than 10% of all stones but make up 60% of all stones found in patients with an ileostomy (Smith 1976). The risk of calcium oxalate stone formation in ileostomy patients is also increased (Bambach et al, 1981). It has been demonstrated that it is the saturation of the urine with various stone forming salts that determines the risk of stone formation (Smith 1976; Robertson et al 1978; Marshall et al 1976). Hence the risk for calcium stone disease can be assessed by a 24 hour urine analysis in the form of an index of the relative probability of stone formation (PSF)(Robertson et al 1978). Similarly the saturation indices for both uric acid and calcium oxalate are higher in stone formers than in normal subjects and so may be used to assess relative risks of stone formation.

Recently ileoanal J-pouch has become an acceptable alternative to conventional ileostomy in patients who require surgery for ulcerative colitis. I have demonstrated (Christie et al 1989) that

the faecal volume and chemistry after J-pouch is similar to conventional ileostomy, resulting in a similar degree of urinary sodium retention. What remains to be answered and what I have addressed in this chapter is:- what is the relative risk of urinary stone formation following this new procedure?

Patients and methods

It can be seen from table I that all patients in this series had their surgery performed for ulcerative colitis.

13 patients with well functioning conventional ileostomies (mean faecal output 463 +/- 46 SD gm per day) together with 15 patients with well functioning J-pouches (mean frequency of bowel movement 4.6 +/- 1.6 SD per day) provided 2 consecutive 24 hour urine collections for analysis. None of these patients had undergone a significant small bowel resection, the only medication being taken was loperamide in 5 of the J-pouch patients. It was interesting to note that 1 of the ileostomy patients was undergoing investigations for renal stones at the time of this study.

My conventional ileostomy group were remote from their surgery (mean duration 14 years, range 1.5-30 years), whereas the J-pouch group had had their surgery relatively more recently (mean duration following loop ileostomy closure, 15 months, range 6-40 months).

All results were compared to a control group of 17 volunteers who provided similar urine collections and were similar to the patients for age and sex. My controls were recruited from either hospital personnel or their friends and families. All volunteers reported no ill health, were on no medication, and were considered

healthy.

Urine Analysis

24 hour urines were analysed for pH, volume, calcium, uric acid, glycosamino-glycan inhibitors (GAGS) together with sodium and potassium content. The methods for these analyses are described in chapter 8.

Calculations and Statistical Analysis

Mean values and standard errors for each urinary constituent were calculated for both the 2 study groups and the control group. The significance of the differences between the groups was assessed using Student's 't' test. Relative supersaturation indices for uric acid and calcium oxalate were obtained for each patient from normograms (Marshall et al 1976) and the relative probability of calcium stone formation (PSF) was calculated for each patient from the formula previously described (Robertson et al 1978). This index is based on a combination of urinary risk factors derived from the comparison of the urinary biochemistry of a stone forming population related to that of a normal control population.

The significance of the differences between the three groups was assessed using the Wilcoxon signed rank test.

Results

Table II shows the 24 hour urinary excretion data for the two patient groups and the normal controls. Compared with the normal controls, the ileostomy group had a significant reduction in urine pH; GAGS; uric acid; and sodium. Their urines contained significantly increased amounts of potassium. The J-pouch group had similar significant reductions of urine volume, pH, GAGS, uric acid and sodium when compared with normal controls. Although the J-pouch group had a lowered value for urinary GAGS, their mean value was significantly greater ($P < 0.05$) than that for the ileostomy group. There were no other differences between these 2 patient groups.

Table III shows the average 24 hour urinary concentration of calcium, oxalate, GAGS, and uric acid for the 2 patient groups and the normal controls.

Significant reductions in the urinary concentration of GAGS and uric acid persisted for the ileostomy group when compared with controls, and notably the concentration of calcium and oxalate were not significantly different from the control values.

A significant increase in oxalate concentration was found for the J-pouch group, but the urinary concentration of calcium, GAGS and uric acid were not different from the normal control values. Interestingly the mean value for urinary GAGS concentration for the J-pouch patients was significantly greater than that for the ileostomy patients ($P < 0.005$).

Table IV shows the mean values for the relative supersaturation of urine with respect to uric acid for the 2 patient groups

compared with the mean for normal controls. The values for both patient groups were significantly higher than normal controls, but significantly lower ($P < 0.05$) than for a group of uric acid stone formers (Bambach et al 1981).

The ileostomy group tended to have a lower value for their relative uric acid supersaturation than the J-pouch group although this tendency did not reach statistical significance. Also shown in table IV are the mean values for the relative urinary supersaturation for calcium oxalate for the 2 patient groups and for the control group. Although there was considerable overlap between the subjects in these 3 groups, the J-pouch group had a significantly increased mean value when compared to normal controls, although significantly less than the reported value for calcium stone formers.

Finally, also shown in table IV are the results for PSF for the 3 groups.

Only the ileostomy group were found to have an increased risk of forming calcium stones. Their risk was not significantly dissimilar to that reported for a group of idiopathic stone formers (Bambach et al 1981).

The PSF relies on a combination of the 5 main risk factors. Calcium, oxalate and pH together control the saturation of urine with calcium salts whereas GAGS and uric acid largely determine the inhibitory activity of the urine (Robertson et al 1978). The increased PSF for the ileostomy group chiefly relates to their significantly lowered mean value for urinary GAGS.

DISCUSSION

The urinary results in this study were consistent with the faecal chemistry results described in chapter 18. J-pouch patients were found to have similar urinary composition to that of their conventional ileostomy counterparts.

The effect of both ileostomy and J-pouch was to significantly reduce urinary pH and volume consistent with persistent faecal loss of water, sodium and bicarbonate previously described. (Christie et al 1989; Clarke et al 1969)

This reduced urine volume produces an increased concentration of urinary calcium, oxalate and uric acid. Uric acid was however not increased in this series with both patient groups secreting less uric acid than controls. This is contrary to the findings of Bambach et al 1981 and Clarke et al 1969.

Previous reports have indicated the importance of uric acid stones in this group of patients and despite the tendency for lowered urinary uric acid concentrations, both patient groups were found to have significantly increased relative supersaturations for uric acid (a more accurate risk factor for uric acid stones), chiefly reflecting the effect of a significantly lowered urinary pH. I note in this regard that the PKa for uric acid crystallisation is 5.4 and that 9 of 13 ileostomy patients and 10 of 15 J-pouch patients had urinary pH's less than this value. Nevertheless the lowered level for uric acid excretion in both patient groups has lowered the mean value of uric acid supersaturation (lower than previous reports for uric acid stone formers), and this may suggest a lower risk of urinary uric acid stones for these two

patient groups.

The calcium oxalate urinary concentration was increased for both patient groups reflecting a normal oxalate excretion in a reduced urinary volume. This has led to an increased value for the relative calcium oxalate supersaturation for both patient groups. The changes in urinary composition which are most important in the formation of calcium stones are an increase in the urinary concentration of calcium, oxalate, an increase in urinary pH and a decrease in the concentration of the GAGS inhibitors (Robertson et al 1978).

Interestingly, the risk of calcium stone formation was not found to be increased in the J-pouch group. This reflects that the raised concentration of calcium and oxalate were compensated by the lowered urinary pH, in the presence of a near normal value of urinary GAGS.

The relative risk of calcium stone formation was significantly increased in the ileostomy group, owing to their significantly lower urinary GAGS concentration. They as a group, were not significantly different from the reported value (Bambach et al 1981) for a group of calcium stone formers.

In summary, there was little difference in the urinary chemistry between our 2 patient groups, consistent with their similar faecal losses. The J-pouch group however had a higher urinary GAGS concentration which lead to a reduction of the risk of calcium stone formation.

Whether there will be an actual difference in the respective

incidences of kidney stones for these two patient groups remains to be seen.

LEGENDS FOR TABLES

- Table I Clinical Details of Patients
- Table II 24 Hour Urinary Excretion Data
- Table III 24 Hour Urinary Constituent Concentrations
- Table IV Mean values for the relative supersaturation of urine with respect to uric acid. Also shown are the relative urinary supersaturations for calcium oxalate for the 2 patient groups and for the control group, and the respective probability of calcium stone formation.

TABLE I**PATIENTS DETAILS**

	Ileostomy patients	J-Pouch patients
No of patients:	13	15
Males	6	8
Females	7	7
Age (mean \pm SEM) yr	44 \pm 3	34 \pm 3
Diagnosis:		
Ulcerative Colitis	13	15
Patients with history of urinary stone after surgery	1	-
Time since resection (mean)	14 yrs	15 months (months since closure of loop ileostomy)
range	(1.5 - 30 yrs)	(6-40) months

TABLE II**24 HOUR EXCRETION OF URINARY CONSTITUENTS**

	Normal Controls n=17 Mean \pm SEM	Ileostomy n=13 Mean \pm SEM		J-Pouch n=15 Mean \pm SEM	
Volume (litres)	1.39 \pm 0.09	1.33 \pm 0.15		1.04 \pm 0.09	*
pH	6.10 \pm 0.09	5.29 \pm 0.09	****	5.40 \pm 0.08	****
Calcium (mmol)	3.6 \pm 0.4	3.8 \pm 0.5		3.0 \pm 0.5	
Oxalate (mmol)	0.18 \pm 0.02	0.22 \pm 0.03		0.24 \pm 0.03	
GAGS (mg)	27.7 \pm 2.1	13.3 \pm 1.7	****	20.0 \pm 2.1	**
Uric Acid (mmol)	2.9 \pm 0.6	2.1 \pm 0.2	*** +	2.2 \pm 0.2	**
Sodium (mmol)	131 \pm 13	67 \pm 8	***	69 \pm 10	**
Potassium (mmol)	56 \pm 4	73 \pm 4	***	67 \pm 8	

* P < 0.05)
 ** P < 0.01)
 *** P < 0.005) compared to normal controls using 't' test
 **** P < 0.0005)
 + P < 0.05 compared to J-pouch patients using 't' test.

TABLE III

CONCENTRATION OF URINARY CONSTITUENTS

	Normal controls n=17 Mean \pm SEM	Ileostomy n=13 Mean \pm SEM	J-pouch n=15 Mean \pm SEM
Calcium (mmol/l)	3.0 \pm 0.4	3.1 \pm 0.4	3.2 \pm 0.6
Oxalate (mmol/l)	0.16 \pm 0.01	0.20 \pm 0.02	0.24 \pm 0.01 ***
GAGS (mg/l)	22.5 \pm 1.6	11.8 \pm 1.9 ****	19.8 \pm 1.9
Uric Acid (mmol/l)	2.4 \pm 0.2	1.8 \pm 0.2 *	2.2 \pm 0.2

* P<0.05)
 ** P<0.01) compared to normal controls using 't' test
 *** P<0.005)
 **** P<0.0005)

+ P 0.005 compared to J-pouch patients using 't' test .

TABLE IV

RELATIVE SUPERSATURATION AND RELATIVE PROBABILITY
OF CALCIUM STONE FORMATION

	Normal Controls n=17 mean \pm SEM	Ileostomy n=13 mean \pm SEM	J-pouch n=17 mean \pm SEM
Uric Acid Supersaturation	-0.92 \pm 0.19	0.29 \pm 0.13 **	0.71 \pm 0.06 **
Calcium Oxalate Supersaturation	0.70 \pm 0.06	0.83 \pm 0.06*	0.86 \pm 0.06*
Probability of Calcium Stone formation	0.24 \pm 0.08	0.58 \pm 0.17 * +	0.18 \pm 0.06

* P < 0.05) compared to normal controls using the Wilcoxon
** P < 0.01) sum of ranks test.

+ P < 0.05 compard to J-pouch patients using the Wilcoxon sum of ranks test.

ILEOSTOMY - mmol/24 hour Urine Specimen

	Vol	pH	Na	K	Ca	PO4	Urate	Oxalate	Aminoglycans
1	1900	5.1	119	91	9.6	47	2.3	0.34	9.3
2	750	5.1	57	70	1.4	21	1.4	0.12	20.7
3	1820	5.5	27	57	3.1	27	3.5	0.17	27.7
4	900	5.9	128	97	2.9	36	2.3	0.44	16.6
5	7700	5.0	11	94	2.7	35	1.4	0.32	8.4
6	1670	4.95	56	59	5.0	24	2.8	0.29	10.7
7	1300	5.30	88	76	3.3	16	2.1	0.23	15.1
8	510	5.70	50	66	3.5	28	1.3	0.15	10.3
9	1205	5.60	70	72	3.7	25	2.5	0.16	14.0
10	1985	5.10	75	55	3.3	24	3.3	0.14	7.9
11	1790	4.85	87	62	4.1	31	1.3	0.17	8.6
12	2000	5.3	98	68	3.5	24	1.0	0.24	17.6
13	750	5.4	32	75	2.9	22	2.3	0.13	6.3

ILEOSTOMY - Concentration of Urinary Constituents (mmol/l)

	Ca	PO4	Urate	Oxalate	GAGS
1	5.05	24.74	1.21	0.18	4.89
2	1.87	28.0	1.87	0.16	27.6
3	1.70	14.83	1.92	0.09	15.22
4	3.22	40	2.56	0.49	18.44
5	3.86	50	2.0	0.46	12.0
6	2.99	14.37	1.68	0.17	6.41
7	2.54	12.31	1.62	0.18	11.62
8	6.86	54.9	2.55	0.29	20.20
9	3.06	20.70	2.08	0.13	11.62
10	1.66	12.09	1.66	0.07	3.98
11	2.29	17.32	0.73	0.09	4.80
12	1.75	12.0	0.50	0.12	8.8
13	3.87	29.33	3.07	0.17	8.4

POUCH mmol/24 Hour Urine Specimen

	Vol	pH	Na	K	Ca	PO ₄	Urate	Oxalate	Aminoglycans
1	840	5.2	20	62	20	30	2.2	0.23	13.4
2	1220	5.7	7	29	0.8	17	1.7	0.09	17.1
3	1750	5.6	152	111	1.5	37	3.2	0.60	23.8
4	720	5.85	37	63	2.4	33	2.2	0.19	16.7
5	950	5.1	97	29	3.1	13	3.5	0.16	9.9
6	1750	5.15	154	133	6.5	57	3.2	0.34	30.8
7	1000	5.5	100	74	2.9	42	3.4	0.29	22.8
8	700	6.0	29	58	7.2	54	1.3	0.16	22.4
9	900	5.0	107	100	4.3	27	1.5	0.23	28.4
10	850	5.4	60	65	3.2	56	1.5	0.32	21.42
11	700	5.3	41	42	2.4	15	2.1	0.09	11.8
12	1350	5.3	150	77	1.8	41	2.1	0.33	38.24
13	1050	5.15	77	75	3.3	29	1.3	0.20	9.24
14	1000	5.2	95	56	1.7	15	2.2	0.20	17.0
15	800	5.8	112	34	1.5	27	1.9	0.25	16.00

POUCH - Concentration of Urinary Constituents (mmol/l)

	Ca	PO ₄	Urate	Oxalate	GAGS
1	2.38	35.71	2.62	0.27	15.95
2	0.66	13.93	1.39	0.07	14.02
3	0.86	21.14	1.83	0.34	13.6
4	3.33	45.8	3.06	0.26	23.20
5	3.26	13.68	3.68	0.17	10.42
6	3.71	32.57	1.83	0.19	17.60
7	2.9	42.0	3.4	0.29	22.8
8	10.29	77.14	1.86	0.23	32.0
9	4.78	30.0	1.67	0.26	31.56
10	3.76	65.88	1.76	0.38	25.2
11	3.43	21.43	3.0	0.13	16.86
12	1.33	30.3	1.56	0.24	28.4
13	3.14	27.62	1.24	0.19	8.8
14	1.7	15	2.2	0.20	17.0
15	1.88	33.75	2.38	0.31	20.0

CONTROLS mmol/24 hour Urine Specimens

	Vol	pH	Na	K	Ca	PO4	Urate	Oxalate	Aminoglycans
1	1200	5.7	158	78	5.6	32	2.0	0.26	41.2
2	1300	5.7	98	70	7.0	25	3.4	0.29	22.7
3	950	5.5	124	39	5.2	39	2.6	0.17	24.3
4	1600	6.4	42	52	2.3	16	2.9	0.25	40.9
5	1880	6.1	155	62	3.7	22	2.9	0.36	20.3
6	1150	5.8	123	42	5.3	22	3.0	0.09	26.2
7	700	5.9	54	52	0.5	9	2.6	0.12	18.5
8	550	6.4	99	48	3.2	20	2.3	0.15	17.6
9	1700	6.0	224	79	3.1	26	3.3	0.19	20.4
10	1200	5.7	145	55	3.7	23	2.3	0.14	25.9
11	1100	6.3	213	60	4.6	54	2.9	0.17	29.5
12	1800	6.3	199	52	3.6	34	2.5	0.19	41.6
13	950	6.7	76	29	2.4	23	3.2	0.11	17.6
14	1700	6.1	155	82	1.60	32.4	4.5	0.22	34
15	1400	6.65	50	34	1.36	13.2	2.3	0.04	19.2
16	1400	6.25	146	52	3.9	27.8	3.5	0.18	38.1
17	1300	6.25	166	61	3.88	26.5	2.6	0.21	32.8

CONTROLS - Concentration of Urinary Constituents (mmol/l)

	Ca	PO4	Urate	Oxalate	GAGS
1	4.67	26.67	1.67	0.22	34.3
2	5.38	19.23	2.62	0.22	17.46
3	5.47	41.05	2.74	0.18	25.58
4	1.44	10.0	1.81	0.16	25.56
5	1.97	11.70	1.54	0.19	10.80
6	4.61	11.70	2.61	0.08	22.78
7	0.71	12.86	3.71	0.17	26.43
8	5.82	36.36	4.18	0.27	32
9	1.82	15.29	1.94	0.11	12
10	3.08	19.17	1.91	0.12	21.58
11	4.18	49.09	2.64	0.15	26.82
12	2.0	18.89	1.39	0.11	23.11
13	2.53	24.2	3.37	0.11	18.53
14	0.94	19.06	2.65	0.13	20
15	0.97	9.42	1.64	0.02	13.74
16	2.83	19.86	2.5	0.13	37.2
17	2.98	20.38	2.0	0.16	25.23

SECTION 5 : THE EFFECTS OF NUTRITIONAL REPLETION

CHAPTER 20 : INTRODUCTION; METHODS AND STUDY DESIGN

Introduction

It is becoming increasingly clear that a patient suffering from acute exacerbations of IBD is not only severely protein depleted but also suffers from a wide range of physiological dysfunction. This dysfunction includes; impaired skeletal muscle function (Jeejeebhoy et al 1986, Klidjian et al 1982, Windsor et al 1988b), impaired respiratory muscle function (Arora et al 1982). Impaired cardiac function (Heymsfield et al 1978), impairment in tissue wound healing (Clark 1919, Pollack et al 1979) and even alteration of psychological function (Keys et al 1950).

Not only are the severities of these physiological impairments associated with the magnitude of protein loss (Windsor et al 1988b) but more importantly they may be accurate indicators of increased surgical risk (Klidjian et al 1982; Windsor et al 1988a).

A short course of IVN although often unable to produce large changes in total body protein (Yeung et al 1979; Elwyn et al 1979; Witney et al 1987) has been shown to improve skeletal muscle enzyme content (Church et al 1986) and fibre type (Church et al 1984), respiratory muscle strength and probably the wound healing response (Haydock et al 1987) in some of these protein depleted patients.

It appears that many of these functional abnormalities may not be the result of a simple loss of lean tissue and hence it is possible that significant improvement in many of these

physiological functions may occur before such lean tissue is regained. It is clear from the earlier literature review that the role of IVN for patients suffering acute exacerbations of IBD remains contentious. In this section I have assessed the effect of a 14 day course of pre-operative IVN on skeletal muscle function, respiratory muscle function, tissue wound healing and psychological function as well as body composition.

Methods

Patients and Controls

Patients

Over a two year period patients presenting with acute exacerbations of IBD to the Department of Surgery, Auckland Hospital, for pre-operative or non-operative IVN were considered for inclusion in this study. The following inclusion criteria had to be satisfied:-

1. patients had to display clear evidence of both depletion and physiological dysfunction. Soon after admission to hospital the decision to give IVN was made on the basis of history and physical examination. Each patient had clear evidence of recent significant weight loss which was associated with clinically obvious physiological dysfunction. Weight Loss was evaluation from the history and physical examination. A preoperative weight loss (recalled well weight minus current measured weight) of more than 10% over the preceding 3 months was considered significant. Because there were considerable difficulties in evaluating body weight loss in an individual patient, confirmation was sought by

physical examination. On physical examination, confirmation that weight loss had occurred was obtained by palpating several skin folds and muscle bellies. If there was little or no fat palpable when subscapular, triceps and biceps skinfolds were palpated, then it was considered that considerable fat had been lost and if on palpation of the bellies of temporalis, supraspinati, biceps, triceps and interossei muscles revealed considerable losses, then this was taken as further evidence that considerable loss of body protein had occurred.

The overall level of Physiological function both mental and physical was also assessed on history and examination. Factors that related to an overall reduction in the patient's capacity for activity (including symptoms of tiredness, malaise, depression and apathy) were particularly looked for. Some specific physiologic functions were also assessed as part of the physical examination. To categorise a patient as having an impairment of any of these functions required clear evidence of a significant change within the time period over which the loss of weight had occurred. Confirmation of exercise intolerance was obtained by observing the patient's general activity level and endurance around the ward. Skeletal muscle function was assessed by having the patient squeeze the examiner's hand who then determined if the squeeze strength was clearly impaired in the light of the patient's age, sex and body habitus. Respiratory muscle function was assessed in the context of a full examination of the respiratory system and particular note was taken of the effort and

sound of coughing as well as the presence of shortness of breath. Impairment of wound healing response was evidenced by unhealed wounds, sores or scratches and/or the presence of skin sepsis. A serum albumin concentration of less than 32 g/l was also considered a significant impairment.

The physical examination also included assessment of disease severity according to the criteria of Trulove and Witts (1955), (ulcerative colitis) and Best et al (1976), (Crohn's disease).

2. Patients received uninterrupted IVN without clinical evidence of frank sepsis i.e. fever, $T > 38.5$; tachycardia $> 110/\text{min}$, BP < 90 mmHg systolic, respiratory rate $> 30/\text{min}$, white cell count < 3.0 or > 12.0 , together with either a positive blood culture or a defined focus of infection (abscess).

3. In the months following discharge, the patients had to enjoy an acceptable level of health; achieve their previous well weight and remain free of any symptoms suggestive of active disease.

This would allow a longitudinal comparison for the patients, allowing a comparison for each patient at the stage of in-hospital care, to that when they were in clinical remission having made a good convalescence.

Only 19 patients satisfied the above criteria and their results are reported in this section.

A subgroup of 10 patients came to surgery following their period of IVN.

Controls

Patients in this study were closely matched for age, sex and height to a group of local well volunteers. These volunteers were historical in that they were recruited prior to this study as part of a large normal study performed in our department. Normal volunteers were mainly recruited from either hospital personnel or their friends and family. In all cases the volunteers reported no ill health, no recent weight loss, were on no medication and were considered healthy by medical staff. Both patients and controls underwent the same tests of body composition and physiological function.

Body Compositional Analysis

Basic body habitus measurements, including body weight and height were performed.

Body composition measurements were carried out by a technique that has been previously described in Chapter 5 . These included measurements of the TBN by IVNAA in conjunction with measurements of TBW by tritium dilution.

TBK was measured directly in the majority of patients using a whole body potassium counter (See chapter 5).

Unfortunately measurements of my control group and four of my patients were performed before the TBK counter had been commissioned. For this sub-group total body potassium was derived indirectly from regression equations using TBW. The relationship between TBK and TBW is well known and has been used to predict variations from normality (Smith 1965).

Muscle Protein

The mathematical model of Burkinshaw et al 1979 was employed to estimate the protein content of muscle and non-muscle lean tissue from TBN and TBK.(see chapter 5).

Resting Energy Expenditure (REE)

Using an indirect calorimeter under standard conditions resting energy expenditure (REE) was measured (see chapter 6). As a measure of metabolic stress I have indexed REE to the FFM : REE/FFM.

Skeletal Muscle Function

1. Voluntary

Maximal voluntary grip strength was measured in the dominant hand using a vigorimeter. The procedure and precision of these measurements are described in chapter 10

2. Involuntary Muscle Function

Using an apparatus based on the principles of Edwards et al 1977, supramaximal ulnar nerve stimulation was performed with square wave pulses for 50 microseconds at frequencies increasing from 10 Hz to 50 Hz for one to two seconds at a time, and the force of contraction recorded. In this manner the F10 : F20 and F10 : F50 force ratios were obtained, together with the maximal force F50. The procedure and precision of these measurements are described in Chapter 10..

Respiratory Muscle Function

Respiratory muscle strength was measured as the mouth pressure with a Validyne bidifferential pressure transducer (Model 45) during a maximal static inspiration (MIP) at functional residual lung capacity and during maximal static expiration (MEP) at total lung capacity. The value of respiratory muscle strength (RMS) was the average value of MIP and MEP expressed in cms of water.

Forced expiratory volume in one second (FEV1), vital capacity (VC) and peaked expiratory flow rate (PEFR) were determined by standard spirometric techniques.

Maximal voluntary ventilation (MVV) or endurance of the respiratory muscles was measured at a fixed frequency.

These procedures and precision of these measurements are described in Chapter 11.

Wound Healing Response

GORE-TEX implants were inserted on the day of commencing IVN (Day 0) and remained in situ for seven days before extraction. At the time of removal, further implants were inserted into the contralateral arm, to span the second week of IVN (day 7). The wound healing response was assessed from the amount of hydroxyproline in the implant at the end of the implantation period (see chapter 9).

Controls were historical, in that they had been previously recruited as part of a large normal study. They were all well, of normal nutritional status, and had no history of recent weight loss, change in dietary intake nor were they on any medication.

Their wound healing response was 1.5 ± 0.1 (Mean \pm SEM) nmol hydroxyproline/mg GORE-TEX tubing (J A Windsor et al 1988d).

Psychological Function

A modification of the SCL-90, a profile of Mood Score (POMS), and a modification of Christensen's Fatigue Scale were administered to the patients just before commencement of the 14 day course of IVN and again 14 days later.

To compare the patients paired results of the Symptom Profile, Global Scores, Mood Score and Fatigue Score at the beginning of IVN to that at the end a Wilcoxon signed rank test was employed as the data could not be assumed normally distributed.

For samples of these questionnaires, scoring procedures and precision please see chapter 12.

Hepatic Secretory Proteins

Plasma transferrin and pre-albumin levels were determined by laser nephelometry.

Medical Management and Nutritional Therapy

Medical management during the period of IVN included bed rest and in all cases prednisone 40mgs per day. In addition three of the patients had sulfasalazine 4-6g/day. IVN solutions contained crystalline amino acids (Synthamin 17%, Baxter Health Care) and energy as a 50:50 mixture of dextrose and Intralipid (Kabi). The patients received 2188 ± 199 SD Kcal and 13.6 ± 1.3 gN per day. Appropriate amounts of electrolytes, trace elements and vitamins

were added separately. The IVN solution, provided in 3 litre bags, was administered through a subclavian catheter by means of a constant infusion pump (IVAC). Insulin was added if the patient had persistent hyperglycaemia.

Assessment of Clinical Course after Surgery (for subgroup n=10)

Major complications were defined as including the following:-

Intra-abdominal sepsis (proven by culture or abnormal drainage or at re-operation), clinically apparent anastomotic leakages, wound dehiscence (requiring re-operation), proven pulmonary emboli (requiring heparinisation), pneumonia (proven by a positive blood and or sputum culture as well as clinical and radiologic evidence of consolidation; atelectasis excluded), myocardial infarction (proven by ECG changes), cerebrovascular accidents (with neurological deficit), and any technical problem that required the patient to undergo a further major surgical procedure. Septic complications were defined as including the following:- intra-abdominal sepsis, pneumonia, septicaemia, (clinical evidence of systemic infection and two separate positive cultures of the same pathogen in the absence of an obvious focus), wound infection (unequivocal signs of inflammation and a positive culture of a pathogen from the pus exuded from the wound), and urinary infection (greater than 1000 organisms/ml on culture). The number of days from operation to discharge were recorded as were all deaths that occurred within 14 days of operation.

Study design

Patients underwent the above measurements of body composition, resting energy expenditure, voluntary + involuntary skeletal muscle function, respiratory muscle function, wound healing and psychological function together with plasma protein estimations on : day 0 (the day prior to commencing IVN), day 7 (seven days later) and on day 14 (following 14 days of IVN).

In addition a small unselected subgroup (n=7) had parameters of skeletal muscle function and respiratory muscle function measured on alternative days over the first week.

To allow comparison of any improvement that occurred in body composition, skeletal muscle function and respiratory muscle function over the period of IVN, to that following a satisfactory extended period of convalescence, all the above patients were brought back on one further occasion. The timing for this final assessment was variable (mean 200 days - range 3 months - 30 months since completion of IVN) but for each patient it was the stage when the patient felt well, had achieved a satisfactory level of function, had reached his previous well weight and was completely free of any symptom that could be suggestive of active disease.

Statistical Analysis

Student's 't' test (paired) was used according to variance equivalence to determine the significance of changes for the patients and to compare the patients' parameters with that of their matched controls.

Response to Nutritional Repletion - Raw Data

Age	Age	FR	RE	WT	WD	W7	W14	W/	W	TEF			TEP			MP									
										0	7	14	TEF	TEP	MP	0	7	14	TEP	MP	0	7	14		
1	34	160	161	14	38.7	39.8	40.8	43.3	59.5	2.6	3.4	4.3	8.8	15.4	6.6	6.5	6.5	6.5	6.74	8.0	2.2	1.7	1.2	2.5	5.6
2	52	175	172	17	65.6	67	67	80.0	77.6	9.0	8.1	7.1	16.2	27.2	11.3	11.4	11.6	12.2	13.1	13.1	3.3	3.1	2.9	4.6	1.7
3	25	164	167	17	43.2	44.3	45.2	55.6	53.4	8.6	10	11.3	14.0	11.5	6.84	6.8	6.7	6.9	7.7	7.7	1.9	2.2	2.5	4.3	5.3
4	20	173	179	12	57	56.5	56.6	63.8	72.7	5.8	5.4	4.9	7.2	6.3	10.38	10.5	11.6	11.5	13.8	13.8	2.4	2.1	1.9	3.0	6.7
5	23	165	168	12	36.9	38.5	39.2	43.2	80.9	2.1	4.6	3.0	3.24	8.0	6.4	6.1	5.9	7.0	14.6	14.6	1.9	2.4	2.5	2.5	8.1
6	22	182	183	22	56.9	55.3	53.3	68.4	77.1	8.3	8.9	9.6	9.4	2.1	8.7	9.7	9.8	11.5	13.2	2.6	2.4	2.2	3.0	10.4	
7	16	171	168	26	42.4	43.3	43.7	50.5	80.9	4.1	5.04	4.8	7.0	8.1	6.46	7.1	7.0	7.6	14.7	2.5	2.4	1.4	3.1	8.1	
8	23	156	167	10	50.5	50.05	50.05	56.3	53.4	16.6	16	16.8	16.0	11.5	4.71	5.35	5.0	6.6	8.1	6.7	5.2	7.5	4.5	5.0	
9	41	169	169	12	46.6	47.6	47.6	53.6	74.2	8.1	5.9	7.0	13	19.7	6.22	6.32	6.0	8.8	10.6	5.6	6.8	6.7	2.8	6.1	
10	27	161	159	13	60.5	60	60	65	63.3	22.3	21.0	26.1	27.0	16.7	6.36	6.79	7.24	7.3	8.9	4.9	4.6	4.1	7.3	5.5	
11	38	178	178	21	55.1	55.6	55.6	69.4	68	2.8	3.5	3.6	11.3	9.7	9.9	10.1	10.1	10.3	11.8	2.0	2.2	2.5	4.5	6.5	
12	46	164	164	11	43.2	44.9	45.2	48.7	67	6.4	9.4	10.2	10.6	17.0	5.3	4.3	5.5	6.8	10.7	6.3	6.8	5.9	2.7	4.6	
13	17	157	159	16	31.8	31.5	31.6	50.5	63.3	10.3	7.7	7.5	10.9	16.7	3.88	3.7	3.8	6.9	8.9	3.6	3.5	3.5	3.3	5.5	
14	48	171	169	15	62	64.7	61.2	75.2	72	21.6	19.5	18.9	27.0	29.3	7.44	8.7	8.3	8.8	10.22	3.6	3.5	3.3	4.9	5.7	
15	36	173	172	15	55.4	50	54.7	67	60.4	15.3	11.6	9.1	13.9	14.7	6.9	6.0	7.7	8.6	9.25	3.5	3.4	2.6	4.4	4.8	
16	20	173	168	22	51.6	53.1	53.7	56.5	80.9	8.3	8.5	8.5	8.8	8.0	8.92	8.9	9.0	9.98	14.5	2.2	2.3	2.5	2.6	8.0	
17	51	165	164	23	43.5	43.7	43.7	48.6	63.6	8.5	8.7	8.9	5.5	16.9	5.9	6.0	6.0	6.9	8.2	2.7	2.9	2.9	2.6	8.0	
18	19	164	168	11	42.6	40.9	41.5	53.4	80.9	3.9	4.6	5.8	7.5	8.0	7.5	6.7	6.5	7.9	14.6	1.5	2.2	2.2	3.4	8.0	
19	19	176	182	16	52	51.0	49.6	59.7	77.1	7.9	9.6	11.3	8.1	7.0	9.8	10.3	8.4	10.9	13.2	5.1	4.7	5.6	2.3	10.4	

Response to Nutritional Repletion - Raw Data

TEK		TEK/FFM				PA				T ₇											
0	7	14	TEK	0	7	14	/	FFM	0	7	14	/	T ₀	T ₇							
1779	1884	1884	2100	3217	0.726	0.730	0.733	0.729	0.746	32.2	44.1	1020	31.7	1215	27.6	11.1	30.0	34.7	81.3	276	-
3302	3228	3302	3885	3247	0.736	0.740	0.750	0.750	0.660	56.3	50.4	1378	24.4	1743	34.6	7.5	8.2	-	27.0	130	-
1974	2280	2228	2603	3063	0.725	0.732	0.775	0.770	0.747	33.9	42.4	1025	30.2	1085	25.6	7.1	-	24.6	29.0	116	-
2851	2817	2784	3274	4756	0.735	0.740	0.740	0.730	0.732	51.1	66.1	1430	28.0	1566	23.7	24.1	-	35.9	38.8	248	290
1868	1946	1934	2109	5286	0.740	0.744	0.762	0.750	0.740	34.7	72.8	1143	32.9	1484	20.4	8.6	26.0	26.3	30.6	-	-
2807	2674	2700	3344	5623	0.711	0.710	0.711	0.740	0.760	48.5	75.1	1522	31.4	1630	21.7	20.2	26.2	-	27.9	181	130
2046	2151	1858	2478	5286	0.755	0.755	0.738	0.740	0.740	38.3	72.8	1151	30.1	1484	20.4	11.3	24.2	31.7	37.1	170	239
1501	2550	2550	2623	3063	0.780	0.758	0.774	0.760	0.746	32.9	42.0	995	30.2	1085	25.8	12.9	10.2	23.0	-	195	150
2854	3178	3093	2623	3913	0.760	0.778	0.779	0.713	0.730	38.5	54.0	1091	28.3	1333	24.7	10.2	11.2	11.2	-	180	255
2678	2691	2658	2809	3376	0.766	0.757	0.710	0.740	0.784	38.2	46.6	1250	32.7	1100	23.6	4.1	44.8	54.7	27.8	312	-
2655	2756	2756	3395	4256	0.750	0.737	0.737	0.748	0.734	48.8	59.2	1440	29.5	1502	25.4	13.4	14.0	15.0	-	242	200
2834	2767	2767	2194	3531	0.780	0.80	0.80	0.744	0.721	37.0	50.1	1183	32.0	1316	26.3	26.0	22.3	15.0	-	198	214
1813	1731	1695	2367	3374	0.860	0.746	0.750	0.744	0.740	21.6	46.6	884	41.0	1286	27.6	14.6	20.6	18.3	-	154	206
2583	2670	2670	3185	3723	0.728	0.726	0.722	0.743	0.725	40.1	52.5	1479	36.9	1198	22.8	44.3	-	32.6	31.9	326	-
2405	2190	2345	3019	3256	0.756	0.761	0.762	0.740	0.728	40.1	45.7	1575	39.3	1200	26.3	21.6	26.6	24.8	36.8	210	270
2500	2600	2600	2684	5286	0.724	0.726	0.730	0.731	0.740	43.2	72.8	1645	38.0	1484	20.4	36.2	39.0	40.0	-	227	236
1984	2072	2182	2182	4139	0.758	0.737	0.737	0.762	0.753	35.0	46.7	123.8	35.4	1222	26.2	19.4	-	27.2	16.0	159	253
2011	2013	1990	2596	5286	0.727	0.745	0.739	0.750	0.743	38.8	72.8	1331	34.3	1484	20.4	33.8	43.7	30.4	-	286	327
3472	3452	3305	2953	5619	0.747	0.745	0.744	0.72	0.764	48.5	75.0	1418	29.2	1030	13.7	18.6	13.6	14.9	34.0	184	195

Response to Nutritional Repletion - Raw Data

TI14	Grip Strength					RMS					FEV					VC												
	T1	0	7	14	/	CS	0	7	14	/	RMS	0	7	14	/	FEV	0	7	14	/	VC	0	7	14	/	VC		
1	463	320	40	44	40	33	45	47	47	63	27.2	2.3	2.2	2.2	2.1	3.1	3.2	3.2	3.2	3.2	3.2	3.2	3.2	3.2	3.2	3.2	3.7	
2	115	252	42	45	50	53	100	119	119	130	143	3.1	3.4	3.4	4.3	5.3	4.1	4.2	4.2	4.2	4.2	4.2	4.2	4.2	4.2	4.2	6.7	
3	269	252	24	28	30	30	60	80	86	103	71	2.5	2.9	2.9	3.1	3.0	3.3	3.4	3.4	3.4	3.4	3.4	3.4	3.4	3.4	3.4	3.5	
4	358	-	44	43	46	34	137	167	221	181	118	4.9	4.9	5.0	5.0	4.9	5.1	5.1	5.1	5.1	5.1	5.1	5.1	5.1	5.1	5.1	6.1	
5	-	186	22	26	29	50	27	52	65	54	139	3.1	3.0	3.5	3.7	5.3	3.3	3.8	3.8	3.8	3.8	3.8	3.8	3.8	3.8	3.8	5.8	
6	-	335	40	41	50	51	136	123	130	158	147	4.2	5.0	5.0	4.7	5.2	5.3	5.1	5.1	5.1	5.1	5.1	5.1	5.1	5.1	5.1	6.5	
7	252	192	20	21	25	38	58	91	71	94	139	2.9	2.9	3.1	3.3	5.3	3.4	3.9	3.8	3.9	3.9	3.9	3.9	3.9	3.9	3.9	5.8	
8	124	-	-	-	-	-	70	71	69	72	71	1.6	1.85	1.85	2.5	3.0	1.7	1.9	1.9	1.9	1.9	1.9	1.9	1.9	1.9	1.9	3.5	
9	151	-	-	-	-	-	92	80	64	103	158	2.9	3.1	3.1	3.2	4.7	3.8	3.6	3.6	3.6	3.6	3.6	3.6	3.6	3.6	3.6	5.7	
10	360	526	25	28	28	21	54	48	90	56	77	3.0	3.4	3.9	3.3	4.7	3.8	3.6	3.6	3.6	3.6	3.6	3.6	3.6	3.6	3.6	5.7	
11	-	-	43	50	52	46	98	120	120	131	143	4.5	4.4	4.4	4.0	1.4	3.3	3.6	3.6	3.6	3.6	3.6	3.6	3.6	3.6	3.6	1.9	
12	-	24	24	30	24	27	41	63	63	56	65	2.3	2.4	2.35	2.5	3.3	5.4	5.6	5.6	5.6	5.6	5.6	5.6	5.6	5.6	5.6	5.1	
13	183	-	-	-	-	-	99	128	60	57	71	2.3	2.4	2.25	2.7	3.0	2.4	2.8	2.8	2.8	2.8	2.8	2.8	2.8	2.8	2.8	4.5	
14	-	365	19	23	28	28	19	34	31	41	58	2.2	2.6	2.25	2.1	2.9	2.3	2.3	2.3	2.3	2.3	2.3	2.3	2.3	2.3	2.3	3.5	
15	210	225	15	18	27	34	38	43	44	63	77	2.2	2.5	2.2	2.1	2.9	2.9	3.6	3.6	3.6	3.6	3.6	3.6	3.6	3.6	3.6	3.3	
16	238	-	35	38	49	50	49	45	65	103	139	3.7	3.6	2.3	3.1	3.8	2.9	3.0	3.0	3.0	3.0	3.0	3.0	3.0	3.0	3.0	5.1	
17	188	-	11	15	24	34	19	31	31	40	38	1.8	2.6	3.9	2.8	5.3	5.2	5.2	5.2	5.2	5.2	5.2	5.2	5.2	5.2	5.2	5.8	
18	327	340	23	26	35	50	56	64	54	82	139	4.0	3.9	2.6	2.8	2.2	2.2	3.1	3.1	3.1	3.1	3.1	3.1	3.1	3.1	3.1	3.0	
19	184	258	34	36	45	51	29	35	36	120	147	3.0	3.5	4.0	4.3	5.3	4.4	4.1	4.1	4.1	4.1	4.1	4.1	4.1	4.1	4.1	5.8	
																												6.5

Response to Nutritional Repletion - Raw Data

PEER			MW			10/20			10/50			F50					
0	7	14	/	PEER 0	7	14	/	MW	0	7	14	/	0	7	14	/	
310	320	330	330	460	140	-	46	49	39	50	-	35	30	2.4	-	2.7	4.5
370	440	440	580	670	160	240	-	21	70	21	31	40	50	9.2	7.2	-	6.8
390	400	410	460	515	130	169	208	281	226	65	26	13	17	5.2	6.9	9.3	6.8
640	640	630	640	680	224	240	281	220	350	83	24	27	35	5.9	5.8	6.3	6.3
470	410	465	500	690	144	160	220	208	408	36	20	-	43	5.5	3.9	-	8.9
550	550	-	580	660	160	240	208	208	369	21	65	40	16	4.8	6.0	6.7	40
355	360	360	420	690	125	176	240	240	408	23	52	36	39	2.3	3.6	3.1	4.4
370	470	470	370	575	123	123	144	54	216	50	29	50	26	3.2	3.2	3.2	1.6
500	525	540	485	580	225	215	-	44	208	37	35	38	24	2.2	2.0	3.9	7.7
480	480	500	480	400	224	240	162	19	54	34	25	15	24	2.2	2.0	3.9	6.7
630	600	600	660	565	274	352	336	40	254	37	26	-	26	7.9	7.6	-	8.0
460	480	490	460	565	176	195	90	36	131	41	39	36	23	5.0	5.6	5.0	3.0
380	385	395	460	515	111	102	88	33	216	41	24	50	45	0.6	2.5	2.6	4.0
330	369	380	310	500	104	112	176	40	172	88	42	55	50	4.1	5.7	5.8	3.0
270	360	400	400	470	112	148	160	51	264	32	45	26	24	4.2	3.8	5.0	5.8
420	490	380	540	690	144	150	160	60	408	39	48	36	24	4.5	6.3	4.4	5.3
270	300	-	320	425	72	84	100	40	171	74	74	-	46	5.3	4.0	-	4.3
420	450	450	460	690	240	264	208	48	408	65	33	32	43	3.0	5.7	6.2	7.0
525	605	610	650	660	192	300	408	41	369	48	40	43	43	3.0	5.7	6.2	7.0

CHAPTER 21 : CHANGES IN SKELETAL MUSCLE FUNCTION

CHAPTER 21 : CHANGES IN SKELETAL MUSCLE FUNCTION

Results

Table I shows the clinical data of the patient group. All 19 patients had severe exacerbations of IBD. The majority , Crohn's disease of high activity (Best et al 1976) and 4 patients suffered from severe ulcerative colitis (Truelove et al 1955). Surgery followed the period of IVN for 10 patients.

Table II shows the clinical and body compositional results for the patients on presentation, together with their matched controls.

The patients had lost 16% of their well body weight including a 35% loss of total body protein, which came chiefly from muscle tissue.

The patients had significantly elevated resting energy expenditures when compared to controls.

Table III shows the effect of IVN on protein stores. IVN produced an increase in visceral proteins, but no improvement occurred in the total body protein of these stressed patients. Furthermore, there was only an 11% accumulation of total body protein at the time of final assessment.

Table IV shows the effect of IVN on skeletal muscle function. The patients had a significant impairment of maximal voluntary grip strength (35% compared with controls) on presentation.

Significant improvement (10%) occurred over the period of IVN and this improvement was confined to the first week of IVN. The total gain in grip strength up to the time of final assessment was only

20% making the magnitude of the initial improvement over the first week of IVN significant. Also shown in table IV are the changes in involuntary muscle function. The force ratios F10: F20, F10 : F50 were significantly impaired at the beginning of this study (17-25%) compared with controls. These parameters of involuntary skeletal muscle function (reflecting rate of fibre relaxation) completely recovered to control values over the first week of IVN. The changes in maximal involuntary force F50 however, paralleled the changes seen with grip strength (although statistical significance was not reached). Patients were significantly impaired on day 0 (18% increased above control values), a modest improvement of 10% occurred over the period of IVN, and this was confined to the first week. Late in the convalescent period there was further improvement, similar to that of grip strength. In table V, the timing of the early improvement in skeletal muscle function is shown for a subset of 7 patients. It can be seen that improvement occurred as early as the fourth day, with no further improvement, during the later period of IVN.

DISCUSSION

My results demonstrated that a short course of IVN given for 4 - 7 days led to an improvement in both voluntary and involuntary skeletal muscle function of 10-20%. This improvement was associated with an increase in circulatory visceral proteins, but no change in total protein stores over the 14 day period.

This study was not the first to demonstrate improved skeletal muscle function following nutritional intervention. Russell et al 1983b showed that obese subjects undergoing two weeks of hypocaloric feeding not only had abnormal involuntary skeletal muscle function, which was further exacerbated by a two week fast, but all objective tests of involuntary muscle function returned towards normal after two weeks of refeeding. Similarly anorectic patients improved after 4 - 8 weeks of oral feeding (Russell et al 1983c). In a similar study a small group (n=4) of undernourished patients suffering from various gastrointestinal disorders sustained an improvement in skeletal muscle function following 4 weeks of conventional IVN (Lopes et al 1982).

These studies however, except for the last small study, have not addressed the changes in skeletal muscle function that follow nutritional repletion in surgical patients. Furthermore, their study protocols did not include repeated measurements earlier than 2 weeks. In the light of my observed early improvement it would have been interesting to compare their early results with those of this present series.

A more recent paper by Chan et al 1987, suggested that complete restoration of involuntary skeletal muscle function can follow

just 48 hours of intravenous loading with glucose and potassium. This is certainly earlier than observed in this present series. Voluntary skeletal muscle function has been previously related to total protein stores and my results are in agreement. Unlike the situation with involuntary skeletal muscle function, patients still remained significantly impaired following the early improvement at 4-7 days. This parameter did not improve to near normal values until later in the convalescent period, coinciding with the accumulation of muscle protein.

As already mentioned, my patients failed to increase their total protein stores during the IVN, despite the significant improvement in their tests of voluntary and involuntary skeletal muscle function. This in itself is not surprising. Other investigators (Jeejeebhoy 1986) have already noted this discrepancy and also the converse - impairment of skeletal muscle has been observed at a time when total body composition was still normal. It is clear that the power exerted by skeletal muscle must be at least a function of not only bulk (muscle protein) but also its inherent nature (not related to changes in total body composition or muscle mass), but rather possibly more related to changes in fibre type (Jeejeebhoy 1986; Church et al 1984), intracellular enzymes (Jeejeebhoy 1986; Church et al 1986), energy or cellular chemistry (Russell et al 1984; Jones et al 1984; Jackson et al 1984).

The early complete improvement seen with involuntary skeletal muscle function in my study may have related to correction of these cellular events, whereas full restoration of muscle strength can only occur following repletion of protein stores, and hence is

a later event. It would have been very interesting to compare the magnitude of the early improvement seen in this stressed group of surgical patients with that of a non-stressed patient group receiving IVN eg., pyloric stenosis - a "group" known to gain protein during 2 weeks of IVN. Clearly we now need a new marker of malnutrition and nutritional repletion. A recent suggested definition (Jeejeebhoy 1988) is that, "Malnutrition is the presence in a body system of abnormalities observed upon withdrawal of nutrients and correctable by refeeding". This would seem to be a very helpful definition and consistent with the results of this present series. Despite the large number of recommended nutritional assessment techniques (anthropometry, biochemistry and prognostic nutritional indices) that have appeared in the literature over the last 15 years^(Grant 1986), no one risk indicator has been shown to be superior to a careful clinical evaluation with particular emphasis on the functional effects that are often seen in patients with significant loss of body weight. It would seem likely that the most sensitive indicator of effective nutritional repletion would be continuous dynamic functional clinical assessment with particular attention to the skeletal muscle system.

It could be argued that the magnitude of this early improvement in skeletal muscle function during nutritional therapy was rather modest, compared with the severe degree of initial impairment in these patients. However, I feel that this selected series clearly demonstrates that in the situation of patients presenting with acute exacerbations of IBD, that the magnitude of improved

skeletal muscle function following nutritional therapy must be related to the persisting degree of impairment still present up to 200 days later when these patients are in "clinical remission".

I would suggest that in the situation of acute IBD, nutritional therapy may well be very efficacious indeed..

The ultimate indicator of effective nutritional therapy must be a lowering of post-operative risk. I am encouraged by the magnitude of my observed early improvement in skeletal muscle function, but whether this will lead to a reduction in post-operative risk can only be answered by a prospective trial.

However, post-operative pneumonia still remains the most important cause of morbidity and mortality after major surgery (Bartlett et al 1973) and hence it remains to be answered whether a short course of IVN will also improve respiratory muscle function and thereby reduce the incidence of post-operative pneumonia in protein depleted surgical patients.

Legends for tables

Table I	Patient clinical data
Table II	Clinical and Body Compositional Details of patients and Controls on presentation.
Table III	Effect of IVN on Protein Stores TBP = total body protein MP = muscle protein
Table IV	Effect of IVN on Skeletal Muscle Function GS = maximal voluntary grip strength F10/20 = Force of 10Hz : Force at 20Hz F10/50 = Force of 10Hz : Force of 50Hz F50 = Force of 50Hz or maximal involuntary force
Table V	Effect of IVN - Timing of the Early Improvement in Skeletal Muscle Function

TABLE I

PATIENT DATA

Number 19
Sex (M:F) 10 : 9

	Outcome	At Final Follow up (200 days)
Disease: Ulcerative colitis - 4)	Surgery - 2)	
- all severe colitis)	Conservative-2)	
above rectum))	- All patients had
)	acceptable health
))
Crohns Disease - 15))	- Restoration to
All active disease-CDAI)	Surgery - 8)	previous well
254 ± 100 (SD)))	weight
- 2 severe colitis)	Conservative-7))	- No symptoms of
- 1 acute entero-))	acute disease
cutaneous fistula))	
- 12 acute small bowel))	
strictures))	

TABLE II

CLINICAL AND BODY COMPOSITIONAL DETAILS OF
PATIENTS AND CONTROLS ON PRESENTATION

	Controls	Patients	P
Number	19	19	NS
Sex (M:F)	10:9	10:9	NS
Age ($\bar{x} \pm$ SD) Yr	34 \pm 9	30 \pm 12	NS
Height ($\bar{x} \pm$ SD) CM	169 \pm 7	168 \pm 8	NS
% Weight Loss ($\bar{x} \pm$ SEM)	-	16.0 \pm 1.0	-
TBP ($\bar{x} \pm$ SEM) Kg	11.3 \pm 0.6	7.3 \pm 0.5	<0.0001
Muscle protein ($\bar{x} \pm$ SEM) Kg	6.5 \pm 0.5	3.4 \pm 0.4	<0.0001
TBF ($\bar{x} \pm$ SEM)	13.3 \pm 1.6	9.1 \pm 1.2	<0.01
RME/FFM ($\bar{x} \pm$ SEM)	24.1 \pm 1.0	32.4 \pm 1.0	<0.0001
Kcal Kg ⁻¹ day ⁻¹ Kg ⁻¹			

$\bar{x} \pm$ SD = Mean \pm standard deviation

$\bar{x} \pm$ SEM = mean \pm standard error of the mean

NS = not significant

Paired 't' test

TABLE III

EFFECT OF IVN PROTEIN STORES

	CONTROLS		PATIENTS		
		Day 0	Day 7	Day 14	Day 200
Weight (Kg)	67.6 ± 2.3*	49.2 ± 2.1	49.4 ± 2.1	49.1 ± 1.8	58.3 ± 2.4
	---	xxxx--	---NS---	---NS---	---xxxx---
		-----	-----	-----	-----
			xxxx		
TBP (Kg)	11.3 ± 0.6	7.3 ± 0.5	7.4 ± 0.5	7.5 ± 0.5	8.6 ± 0.4
	---	xxxx--	---NS---	---NS---	---xxxx---
		-----	-----	-----	-----
			xxxx		
MP (Kg)	6.5 ± 0.5	3.4 ± 0.4	3.4 ± 0.4	3.4 ± 0.4	3.6 ± 0.3
	---	xxxx--	---NS---	---NS---	---NS---
		-----	-----	-----	-----
			xxxx		
Plasma Transferrin (mg/dl)	263 ± 8	215 ± 12	223 ± 15	253 ± 23	291 ± 32
	---	x-----	---NS---	---NS---	---NS---
		-----	-----	-----	-----
			x		
			NS		
Plasma Prealbumin (mg/dl)	24.0 ± 1.0	19.0 ± 2.0	23.6 ± 3.2	27.5 ± 2.3	28.0 ± 2.3
	---	x-----	---NS---	---NS---	---NS---
		-----	-----	-----	-----
			x		
			NS		

*Shown \bar{x} + SEM

Paired 't' test

x p < 0.05
 xxxx P < 0.0005

TABLE IV

EFFECT OF IVN ON SKELETAL MUSCLE FUNCTION

	<u>Controls</u>				<u>Patients</u>		
	Day 0	Day 7	Day 14	Day 200	% Impairment Day 0	% Improvement Day 7	% Improvement Day 200
<u>Voluntary</u>							
G.S (Kg)	40 ± 3*	26 ± 3	30 ± 3	30 ± 5	35	10	20
	---xxxx---	---xx---	---NS---	---xx---			
	-----x-----						
<u>Involuntary</u>							
F10/20 (%)	48 ± 4	58 ± 4	47 ± 3	42 ± 4	17	19	31
	---x---	---x---	---NS---	---NS---			
	-----NS-----						
F10/50 (%)	33 ± 3	44 ± 3	36 ± 3	32 ± 3	25	17	14
	---x---	---NS---	---NS---	---NS---			
	-----xxxx-----						
	-----NS-----						
F50 (kg)	5.0±0.5	4.1±0.5	4.6±0.5	4.6±0.5	18	10	26
	-----x-----	---NS---	---NS---	---NS---			
	-----x-----						
	-----NS-----						

* Shown $\bar{X} \pm$ SEM

Paired 't' test

x P < 0.05
 xx P < 0.01
 xxx P < 0.005

G.S. = maximal voluntary grip strength
 F10/20 = force of 10 Hz : force at 20 Hz
 F10/50 = force at 10 HS : force at 50 Hz
 F50 = force at 50 Hz or maximal involuntary force

TABLE V

**EFFECT OF IVN - TIMING OF THE EARLY
IMPROVEMENT IN SKELETAL MUSCLE FUNCTION**

N=7	Day 0	Day 2	Day 4	Day 7	Day 14	Day 200
<u>Voluntary</u>						
G.S.(Kg)	26 ± 4*	26 ± 4	31 ± 5	32 ± 5	33 ± 4	39 ± 4
	---NS---	---xxx---	---NS---	---NS---	---x---	
<u>Involuntary</u>						
F10/20(%)	57 ± 3	52 ± 4	44 ± 3	44 ± 3	46 ± 3	42 ± 3
	---NS---	---x---	---NS---	---NS---	---NS---	
F10/50(%)	40 ± 4	36 ± 4	34 ± 2	34 ± 3	31 ± 3	36 ± 4
	---NS---	---NS---	---NS---	---NS---	---NS---	
F50 (Kg)	5.6±0.8	5.6±0.8	5.3±0.4	6.0±0.5	6.0±0.5	6.1±0.6
	---NS---	---NS---	---NS---	---NS---	---NS---	
		-----NS-----				

* Shown $\bar{x} \pm SEM$

Paired 't' test

x P<0.05
 xx P<.01
 xxx P<0.005

CHAPTER 22: CHANGES IN RESPIRATORY MUSCLE FUNCTION

CHAPTER 22: CHANGES IN RESPIRATORY MUSCLE FUNCTION

Introduction

Despite the many advances in anaesthetic and surgical techniques, the incidence of post-operative pneumonia has not changed appreciably over the past 30 years (Garibaldi et al 1981). It still remains the most important cause of morbidity and mortality after major abdominal surgery (Bartlett et al 1973).

Recently in a prospective study of 80 patients (Windsor et al 1988c), a pre-operative protein depletion of 35% was shown to be associated with a significant impairment of respiratory function (10-20%), together with an increased incidence of post-operative pneumonia and prolonged hospital stay.

There is already data showing that Intravenous Nutrition (IVN) increases body stores of protein (Whitney et al 1987), reverses abnormalities of skeletal muscle fibre type, enzymes, (Church et al 1984, 1986) and possibly function. It remains to be seen, whether a short course of IVN will improve respiratory muscle function and in this way hopefully reduce the incidence of post-operative pneumonia.

RESULTS

Table I shows the clinical data for the patient group. All 19 patients had severe exacerbations of IBD. The majority had Crohn's disease of high activity but 4 patients suffered from severe ulcerative colitis. Surgery followed the period of IVN for 10 patients.

Table II shows the clinical and body compositional results for the patients on presentation, together with their matched controls.

Close matching was achieved for the patients and their respective controls for age, sex and height.

The patients had lost 16% of their well body weight including a 35% loss of total body protein, which came chiefly from muscle tissue.

The patients had significantly elevated resting energy expenditures when compared to controls.

Table III indicates the effect of IVN on protein stores. Although IVN produced an increase in visceral proteins, no improvement occurred in the total body protein of these stressed patients. It is interesting that there was only an 11% accumulation of total body protein at the time of final follow-up and hence the patients at this stage were still significantly protein depleted.

Table IV shows the effect of IVN on respiratory muscle function and voluntary maximal grip strength.

It can be seen that the patients displayed a significant major impairment (25-40%) in all tests of respiratory muscle strength (RMS, FEV1, VC, PEFr), respiratory muscle endurance (MVV), and grip strength when compared to matched controls on day 0.

Significant improvement (2-15%) occurred over the period of IVN for all parameters of respiratory muscle function and grip strength, and with the exception of MVV this improvement was totally confined to the first week of IVN.

Furthermore, the total gain in respiratory muscle function up to the time of final assessment was only 10 -25% and hence the patients had therefore a persisting although less severe level of impaired respiratory function at this late stage. This makes the magnitude of the early improvement during IVN more significant.

Table V shows the timing for this early improvement in respiratory muscle function for a subset of 7 patients. It indicates that the observed improvement in respiratory muscle function occurred around 4 days with no significant further functional gain at 14 days.

Table VI shows the clinical data of the surgical group and their post-operative course.

No patients developed post-operative pneumonia or other septic complications.

One patient (M26) developed a complete SMA syndrome requiring two months of IVN before a further relaparotomy. The mean duration of hospital stay did not include this patient. It did include, however, three patients who received two weeks of post-operative IVN:- M54, who developed a subclinical anastomotic leak from an

ileoanal J-pouch anastomosis; F50 who had undergone a resection including a long segment of small bowel, and finally F27 who had underwent multiple small bowel stricturoplasties for Crohn's disease.

DISCUSSION

My results have demonstrated that a short course of IVN for 4 - 7 days leads to an improvement in all parameters of respiratory muscle function of approximately 5 - 10%. This occurred in association with an increase in circulatory visceral proteins, but without a measured improvement in total protein stores. This is consistent with their high disease activity and increased measured resting energy expenditure.

This study is not the first to demonstrate improved respiratory muscle function, following nutritional intervention. Kelly et al 1984 examined respiratory muscle strength and body compositional changes in 59 patients receiving IVN. They found not only a marked respiratory muscle weakness in those patients with wasted body cell masses, but were able to show a significant correlation between the improvement in respiratory muscle strength following nutritional therapy. My patients, unlike those of Kelly, failed to gain lean tissue despite their significant gain in respiratory muscle strength. Furthermore, their gain was an earlier event. It would have been interesting if Kelly had also performed his measurements in this earlier period. It is clear that my delayed further gain in respiratory function during the convalescent period was associated with accumulation of muscle protein, and this process was essential if further or full restoration of function was to occur. If my patients had not been a uniformly stressed group, there may have been a further improvement in respiratory muscle function beyond the four days, associated with a gain in protein.

The magnitude of the observed early respiratory muscle function improvement may initially seem rather modest but when viewed in the context of zero further gain following up to 14 days of IVN and the total gain of only (10-25%) occurring in respiratory muscle function later in the convalescent period following an 11% gain in protein stores, then this early improvement becomes more significant.

Furthermore, in the previous study (Windsor et al 1988c) patients developing post-operative pneumonia had to have a pre-existing level of respiratory muscle function of around 80% of predicted control values and hence as seen in Fig I my prompt improvement in respiratory muscle function reached this range and hence may be very efficacious in terms of reducing the incidence of post-operative pneumonia in protein depleted patients. (It should also be noted that the patients in this series initially had a much more severe level of respiratory muscle impairment than in this previous study). Furthermore, in the previous study, the depleted surgical patients were found to have 20% incidence of post-operative pneumonia. It is interesting that none of the 10 patients going forward to surgery (Table VI) developed clinical or radiological evidence of pneumonia and assuming a similar expectant incidence of 20% this difference became highly significant ($P < 0.01$)

The changes in respiratory muscle function presented in this chapter are similar to the changes already described for skeletal muscle function.

What does all this mean to a busy clinician whose task it is to

manage patients hospitalised with acute exacerbations of IBD? The following facts have now been established. (1) Nutritional support with IVN prevents further loss of total body protein (Dickenson et al 1980). (2) Within a few days of IVN respiratory muscle function and skeletal muscle function improve significantly but not to normal values. (3) The magnitude of the improvement ($\sim 12\%$) is probably sufficient to be clinically beneficial (Windsor et al 1988c). After this early improvement in physiological function further improvements are associated with increases in body stores of protein and are as a consequence, much slower. In conclusion I suggest that this work supports the use of IVN in patients with acute exacerbations of IBD.

LEGENDS FOR TABLES

Table I Patients clinical data

Table II Clinical and Body Composition Details of patients and controls on presentation

Table III Effect of IVN on Protein Stores
TBP = total body protein
MP = muscle protein

Table IV Effect of IVN on Respiratory Muscle Function

RMS = Respiratory Muscle Strength
FEV1 = Forced Expiratory Volume in 1 second
PEFR = Peaked Expiratory Flow Rate
MVV = Maximum Voluntary Ventilation
GS = Maximal Voluntary Grip Strength

Table V Effect of IVN - Timing of the Early Improvement in Respiratory Muscle Function

Table VI Clinical Data of Surgical Group and Post-Operative Course.

TABLE I

PATIENT CLINICAL DATA

Number 19
Sex (M:F) 10 : 9

	Outcome	At Final Follow up (200) days
Disease: Ulcerative colitis - 4)	Surgery - 2)	
-all severe colitis above)	Conservative - 2)	
rectum)		- all patients
		had acceptable
		health
Crohn's Disease - 15)	Surgery - 8)	Restoration to
All active disease - CDAI)		previous well
254 + 100 (SD))		weight
- 2 severe colitis)	conservative - 7)	No symptoms of
- 1 acute enterocutaneous)		acute disease
fistula)		
- 12 acute small bowel)		
strictures)		

TABLE II

**CLINICAL AND BODY COMPOSITIONAL DETAILS OF
PATIENTS AND CONTROLS ON PRESENTATION**

	Controls	Patients	P
Number	19	19	NS
Sex (M :F)	10 : 9	10 : 9	NS
Age ($\bar{x} \pm$ SD) yr	34 \pm 9	30 \pm 12	NS
Height ($\bar{x} \pm$ SD) CM	169 \pm 7	168 \pm 8	NS
% Weight Loss ($\bar{x} \pm$ SEM)	-	16.0 \pm 1.0	-
TBP ($\bar{x} \pm$ SEM) Kg	11.3 \pm 0.6	7.3 \pm 0.5	<0.0001
Muscle Protein ($\bar{x} \pm$ SEM) Kg	6.5 \pm 0.5	3.4 \pm 0.4	<0.0001
TBF ($\bar{x} \pm$ SEM) Kg	13.3 \pm 1.6	9.1 \pm 1.2	<0.01
RME/FFM ($\bar{x} \pm$ SEM) Kcal Kg ⁻¹ day ⁻¹ Kg ⁻¹	24.1 \pm 1.0	32.4 \pm 1.0	<0.0001

$\bar{x} \pm$ SD = Mean \pm standard deviation

$\bar{x} \pm$ SEM = Mean \pm standard error of the mean

NS = Not significant

Paired 't' test

TABLE III

EFFECT OF IVN PROTEIN STORES

	Controls		Patients		
		Day 0	Day 7	Day 14	Day 200
Weight (Kg)	67.6 _{-2.3} *	49.2 _{-2.1}	49.4 _{-2.1}	49.1 _{-1.8}	58.3 _{-2.4}
	-----xxxx-----	-----NS-----	-----NS-----	-----xxxx-----	
		-----	-----xxxx-----		
		-----	-----xxxx-----		
TBP (Kg)	11.3 _{-0.6}	7.3 _{-0.5}	7.4 _{-0.5}	7.5 _{-0.5}	8.6 _{-0.4}
	-----xxxx-----	-----NS-----	-----NS-----	-----xxxx-----	
		-----	-----xxxx-----		
MP (Kg)	6.5 _{-0.5}	3.4 _{-0.4}	3.4 _{-0.4}	3.4 _{-0.4}	3.6 _{-0.3}
	-----xxxx--	-----NS-----	-----NS-----	-----NS-----	
		-----	-----xxxx-----		
Plasma Transferrin (mg/dl)	263 ₊₈	215 ₊₁₂	223 ₊₁₅	253 ₊₂₃	291 ₊₃₂
	-----x-----	-----NS-----	-----NS-----	-----NS-----	
		-----	-----x-----		
		-----	-----NS-----		
Plasma Prealbumin (mg/dl)	24.0 _{-1.0}	19.0 _{-2.0}	23.6 _{-3.2}	27.5 _{-2.3}	28.0 _{-2.3}
	-----x-----	-----NS-----	-----NS-----	-----NS-----	
		-----	-----x-----		
		-----NS-----			

*Shown \bar{x} + SEM

Paired 't' test

TBP = Total Body Protein

x P < 0.05

MP = Muscle Protein

xxxx P < 0.0005

TABLE IV

EFFECT OF IVN ON RESPIRATORY MUSCLE FUNCTION

	Controls	Day 0	Day 7	Day 14	Day 200	% Impairment Day 0	% Improvement Day 7	% Improvement Day 200
RMS (cm H ₂ O)	104 ± 10*	65 ± 8	76 ± 9	78 ± 10	90 ± 9	38	11	25
	----- ---xxxx-- -----x	----- ---xxxx-- -----x	----- ---xxxx-- -----x	----- ---NS--- -----x	----- ---x--- -----			
FEVI (litres)	4.0 ± 0.3	3.0±0.2	3.2±0.2	3.3±0.2	3.4±0.2	25	5	10
	----- ---xxxx-- -----	----- ---xxxx-- -----	----- ---xx--- -----	----- ---NS--- -----	----- ---NS--- -----			
VC (litres)	4.8 ± 0.3	3.6±0.3	3.7±0.2	3.8±0.2	4.1±0.2	25	2	10
	----- ---xxxx-- -----	----- ---xx--- -----	----- ---xx--- -----	----- ---NS--- -----	----- ---xxx--- -----			
PEFR (litres)	576 ± 23	428±25	454±22	462±22	479±25	36	15	19
	----- ---xxxx-- -----	----- ---xx--- -----	----- ---xx--- -----	----- ---NS--- -----	----- ---NS--- -----			
MVV (litres/min)	268 ± 27	162±12	195±17	197±18	203±20	40	13	16
	----- ---xxxx-- -----	----- ---xxxx-- -----	----- ---xxxx-- -----	----- ---x--- -----	----- ---x--- -----			
GS (Kg)	40 ± 3	26±3	30±3	30±5	34±3	35	10	20
	----- ---xxxx-- -----	----- ---xxxx-- -----	----- ---xxxx-- -----	----- ---NS--- -----	----- ---xxx--- -----			

*Shown \bar{x} ± SEM Paired 't' test x P < 0.05 xx P < 0.01 xxx P < 0.005 xxxxx P < 0.0005

TABLE V

EFFECT OF IVN ON RESPIRATORY MUSCLE FUNCTION - THE TIMING OF EARLY IMPROVEMENT

n = 7	Day 0	Day 2	Day 4	Day 7	Day 14	Day 200
RMS (cm water)	50 ± 7*	50 ± 7 -----NS----- xxx-----	61 ± 8 -----NS-----	60 ± 8 -----NS-----	62 ± 9 -----NS-----	74 ± 11 -----x-----
FEVI (litres)	3.3 ± 0.3	3.3 ± 0.3 -----NS-----	3.4 ± 0.2 -----NS-----	3.4 ± 0.2 -----NS-----	3.5 ± 0.3 -----NS-----	3.8 ± 0.2 -----x-----
PEFR (litres/MIN)	419 ± 42	411 ± 39 -----NS-----	447 ± 32 -----x-----	444 ± 31 -----NS-----	442 ± 30 -----NS-----	509 ± 35 -----NS-----
GS (KG)	26 ± 4	26 ± 4 -----NS-----	31 ± 5 -----xxx-----	32 ± 5 -----NS-----	33 ± 4 -----NS-----	39 ± 4 -----x-----

*Shown $\bar{x} \pm SEM$ Paired 't' test x P < 0.05
 xx P < 0.01
 xxx P < 0.005

TABLE VI**CLINICAL DATA OF SURGICAL GROUP AND POST OPERATIVE COURSE**

Age (Years)	33 \pm 13*
Height (cm)	158 \pm 47
Sex (M : F)	5 : 5
Incision site:	10 - lower abdominal
Respiratory disease (no of patients)	0
Obstructive (mod - severe)	0
Restrictive (mod - severe)	0
Combined (mod - severe)	0
FEVI/VC	0.81 \pm 0.08
Smokers (no of patients)	
Light	2
Moderate	4
Heavy	1
Duration of anaesthetic (hours).	3.35 \pm 1.4
Post-operative course:	
Major	1
Septic	0
Pneumonia	0
Wound infection	0
Death	0
Hospital stay (days)	14.8 \pm 5.5

*Shown $\bar{x} \pm$ SD

FIGURE LEGENDS

Fig. 1. shows the effect of IVN on Respiratory Muscle Function

FIGURE I

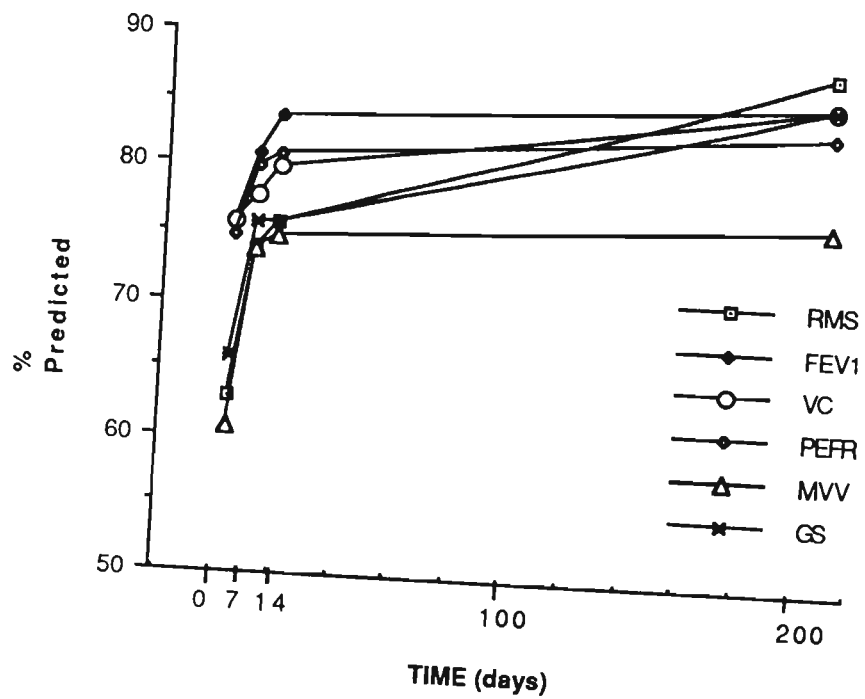

CHAPTER 23: CHANGES IN THE WOUND HEALING RESPONSE

Introduction

In this section I have examined the wound healing response in the same patient group. I have also considered whether there would be any improvement in wound healing following a short course of IVN. It has been widely accepted that PEM is associated with impaired wound healing (Clarke, 1919; Pollack 1979) but this has recently been questioned (Windsor et al 1988d). Recent work has also suggested that changes in wound healing following nutritional intervention may occur at an early stage (Haydock et al 1987).

Results

Unfortunately owing to initial problems with the analysis of hydroxyproline with resultant loss of samples, together with individual patient reluctance to take part in this aspect of the study, I can only present complete wound healing data on 9 patients (M2, F7 \bar{x} age 28 +/- 10 SD years, mean wt loss 13 +/- 3 SD %). Nevertheless, I am confident they represent a reasonable sample of the total patient group.

Table I shows the effect of IVN on the wound healing response, together with the changes in visceral and total protein stores.

There was a strong tendency for the patients to have an impaired wound healing response on presentation when compared with controls. Owing to patient variability and the small sample size, this did not however reach statistical significance. There was however, a significant improvement in the patients wound healing response following one week of IVN. This coincided with significant gains in visceral proteins but not total protein.

Discussion

This data is consistent with other recent data from our department (Haydock et al 1987) and is further objective evidence that the wound healing response in surgical patients requiring IVN is improved by this treatment. This improvement was seen after only one week of nutritional therapy and before there had been any change in total body protein stores.

It is tempting to relate the strong tendency for a lowered wound healing response on presentation to the patients lowered protein

stores, but this would not explain their subsequent early improvement following IVN.

Windsor et al 1988d has stressed the importance of recent dietary intake for at least one week prior to wounding - regardless of the extent of PEM. I have no dietary information on the patients at the time of commencing IVN but it would seem likely that their dietary intake was inadequate. Clearly the early improvement in wound healing following just 1 week of IVN, and furthermore the similar early improvements seen previously with skeletal muscle and respiratory muscle function would all suggest the importance of a "labile protein pool". This pool may be repleted or depleted by brief abrupt changes in recent protein intake and hence repletion may provide a major biological advantage in the face of persisting depleted total body protein stores, for a range of body functions including wound healing. This is consistent with the results of other investigators eg., using isotopic techniques, Waterlow et al 1981, showed a fall in the rate of protein synthesis within 2 days of a protein free diet.

Our technique for measuring the wound healing response examines the wound healing response in a very general sense and certainly is not a measure of ultimate wound strength. Nevertheless this technique has been shown to monitor and detect (Haydock et al 1986) the very biological events including the acute inflammatory response and cellular invasion, that protein depletion has been thought to affect.

All these processes play a vital role in host defence and the

measurement of an impairment or an improvement in them must be of clinical significance for the pre-operative patient.

LEGEND FOR TABLE

Table I

The effect of IVN on visceral and total body protein stores and the wound healing response.

TABLE I

EFFECT OF IVN ON THE WOUND HEALING RESPONSE

	Controls		Patients	
	Day 0	Day 7	Day 7	Day 14
Plasma Transferrin (mg/dl)	263 ₋₈ *	182 ₋₁₇	209 ₋₁₁	250 ₋₃₅
	-----x-----	-----NS-----	-----NS-----	
		-----x-----		
		-----NS-----		
Plasma Prealbumin (mg/dl)	24 ₋₁	14 ₋₂	19 ₋₂	23 ₋₂
	-----xxx-----	-----x-----	-----NS-----	
		-----xx-----		
		-----NS-----		
Total Body Protein (Kg)	9.3 _{-0.6}	6.3 _{-0.6}	6.3 _{-0.6}	6.1 _{-0.4}
	-----xxxx-----	-----NS-----	-----NS-----	
Wound Healing response Hydroxyproline (nmol/mg GORE-TEX)	1.5 _{-0.1}	1.0 _{-0.6}	2.9 _{-0.7}	
	-----NS-----	-----x-----		

*Shown $\bar{x} \pm$ SEM

Paired 't' Test

- x P < 0.05
- xxx P < 0.025
- xxx P < 0.005
- xxxx P < 0.001

CHAPTER 24 : CHANGES IN PSYCHOLOGICAL FUNCTION

Introduction

It is less appreciated that malnourished patients frequently suffer from a major impairment of psychological function (Keys et al 1950) . This impairment may manifest as a decrease in the level of alertness, decreased ability to concentrate, general irritability and depression, culminating in a reluctance on behalf of the patient to post-operatively make the voluntary efforts eg., coughing and mobilisation that are , required for a rapid uncomplicated recovery from major surgery. Whilst I have demonstrated in the previous chapters of this section that a two week course of IVN may reverse some of the many abnormalities of body composition and function (Church et al 1984, Witney et al 1987, Haydock et al 1987, Christie et al 1988b) little is known of its effects on the psychomotor function of these patients. Every clinician will stress the importance of having a strongly motivated patient following major surgery.

In this chapter I have described the changes in psychological function in the same selected group of patients receiving a two week course of IVN for acute exacerbations of IBD.

RESULTS

Table I shows the reader of the patient's clinical data.

Table II again shows that the patients and control subjects were well matched with respect to sex distribution, age and height.

Table II also shows the mean weight, TBP, TBF and RME/FFM for the control subjects. The patient's had lost on average 18.4 Kg (27%) of their body weight, including 4.0 Kg (35%) protein and 4.2 Kg (32%) fat. The patients also had significantly higher RMES, relative to FFM, than the controls. The mean elevation being 8.3 Kcal/Kg/day (34%).

Table III demonstrates that the patients body weight and TBP did not change significantly during the 14 day period of IVN.

Table III shows that the decreased levels of plasma transferrin and plasma pre-albumin increased significantly over a period of IVN to reach control values.

Figure I, shows a comparison between the SCL symptom profile for the patients at the time of commencing IVN and the SCL profile 14 days later. There was no overlap between these two curves and both curves had very similar profiles.

Prior to commencing IVN the patients demonstrated significantly high levels of depression, somatisation and anxiety but not hostility. These dimensional elevations reflected the natural somatic and psychological unpleasantness of their serious illness or malnutrition and led to significantly increased levels of general distress as indicated by significant elevations of the 3 global scores. When the psychological profile was re-measured 14

days later, there had been a significant uniform improvement for all 5 primary symptoms and global scores. The magnitude of this improvement was statistically significant approaching LSD, making the means for these patients approach normal control values.

In Figure II, can be seen the (POMS) symptom profile. Allowing for the reciprocal scoring for the vigour dimension, again there appears to be two distinct curves with no overlap. The patients at the beginning of this study exhibited increased fatigue and reduced vigour levels. Over the study period there was an improvement in all 5 symptom dimensions leading to, as seen in figure III, a significant improvement in the overall value for the POMS mood score. A similar significant improvement was also seen with the fatigue score of Christensen.

DISCUSSION

My results demonstrate that psychological function improves over the two week period of IVN. Although circulating plasma protein levels returned to normal values this improvement in skeletal muscle function and psychological function was quite independent of the changes in body protein stores and there was no improvement in protein stores over the study period. It has often been the clinical impression that patients look and feel better within a few days of commencing IVN. These malnourished surgical patients displayed significant alterations of mood - with high levels of somatisation, depression and fatigue culminating in abnormally high levels of psychological stress. This is not the first time that malnutrition and altered mood states have been linked. Keys noted an association through his studies of experimental starvation in 1950. This association has been recognised more recently through studies of cancer cachexia (Westin et al 1988). It has also been demonstrated that over the period of IVN there was a significant improvement in all symptom dimensions and global scores indicating a reduction to near normal levels of distress and fatigue.

As previously mentioned there was no significant gain in protein stores over the study period. Recently Laessle et al 1988, by means of a multivariate statistical approach, examined the relationship between depression and starvation in a sample of 64 patients with anorexia nervosa or bulimia. In this study depressive symptoms were shown not only to be related to malnutrition as defined by lower body weight but also a depressive

state was associated with more short term periods of acute starvation (reflected by pathologically high levels of Beta-hydroxybutyric acid), in the absence of weight loss. This study may help to explain the prompt early improvement in psychological function seen in my patient group..

This improved psychological function may not only be of extreme assistance to the patient in the early post-operative period in terms of early mobilisation and respiratory effort, but later it may be of major importance in reducing the magnitude and duration of post-operative fatigue.

LEGENDS FOR TABLES

Table I Patients clinical data

Table II Clinical and Body Compositional Details of Patients
and Controls on Presentation

Table III Effect of IVN on Protein Stores and hepatosecretory
Proteins.

TABLE I

PATIENTS CLINICAL DATA

Number : 19

Sex (M:F) 10:9

DISEASE

SURGERY

Ulcerative colitis - 4
- all severe colitis above rectum

Surgery - 2
Conservative - 2

Crohn's disease - 15

All active disease - CDAI*254+100 (SD) Surgery - 8
- 2 severe colitis

- 1 acute enterocutaneous fistula
- 12 active small bowel disease

Conservative - 7

* Chron's disease activity index

TABLE II**PATIENTS AND CONTROLS AT PRESENTATION**

	Controls	Patients	P*
Number	19	19	NS
Sex	10:9	10:9	NS
Age (y)	34 \pm 9	30 \pm 12	NS
Height (cm)	169 \pm 7	168 \pm 8	NS
Weight (kg)	67.6 \pm 10.0	49.2 \pm 9.2	< 0.001
TBP (kg)	11.3 \pm 2.6	7.3 \pm 2.2	< 0.0001
TBF (kg)	13.3 \pm 6.9	9.1 \pm 5.2	< 0.01
RME/FFM (Kcal kg ⁻¹ day ⁻¹)	24.1 \pm 4.4	32.4 \pm 4.4	< 0.0001

Shown $\bar{x} \pm 1$ SD

* Paired 't' test

TBP = Total Body Protein

TBF = Total Body Fat

RME/FFM = Ratio of resting metabolic expenditure to the fat free body mass

TABLE III

CHANGES IN PROTEIN NUTRITURE OVER STUDY PERIOD

	Controls		Patients	
		Day 0		Day 14
Weight (kg)	67.6 ± 2.3*	49.2 ± 2.1	NS	49.1 ± 1.8
	xxxx			
TBP (kg)	11.3 ± 0.6	7.3 ± 0.5	NS	7.5 ± 0.5
	xxxx			
Plasma Transferrin (mg/dl)	263 ± 8	215 ± 12	x	253 ± 23
	x		x	
		NS		
Plasma Pre-Albumin (mg/dl)	24.0 ± 1.0	19.0 ± 2.0	x	27.5 ± 2.3
	x		x	
		NS		

* shown $\bar{x} \pm$ SEM

* Paired 't' test.

TBP = Total Body Protein x P < 0.05

xxxx P < 0.0005

FIGURE LEGENDS

Fig.I. Comparison of the SCL symptom profile at the time of commencing IVN (A) to that profile 14 days later (B). Shown are the means and standard errors of the means and these are expressed as T-scores and % ranks. The mean value for normative data is indicated by the horizontal line $T = 50$.

* Indicates a significant difference between mean values (* $P < 0.05$, ** $P < 0.0005$)

Fig. II Comparison of the POMS symptom profile at the time of commencing IVN (A) to that profile 14 days later (B). Shown are the means and standard errors of the mean and these are expressed as T scores.

The mean value for normative data is indicated by the horizontal line $T = 50$.

Fig.III Comparison of the mean values for the mood score (POMS) and fatigue score (Christensen) at the time of commencing IVN (A) to that value 14 days later (B) Also shown is the standard error of the mean.

* Indicates a significant difference between mean values (* $P < 0.05$, ** $P < 0.005$).

FIGURE I

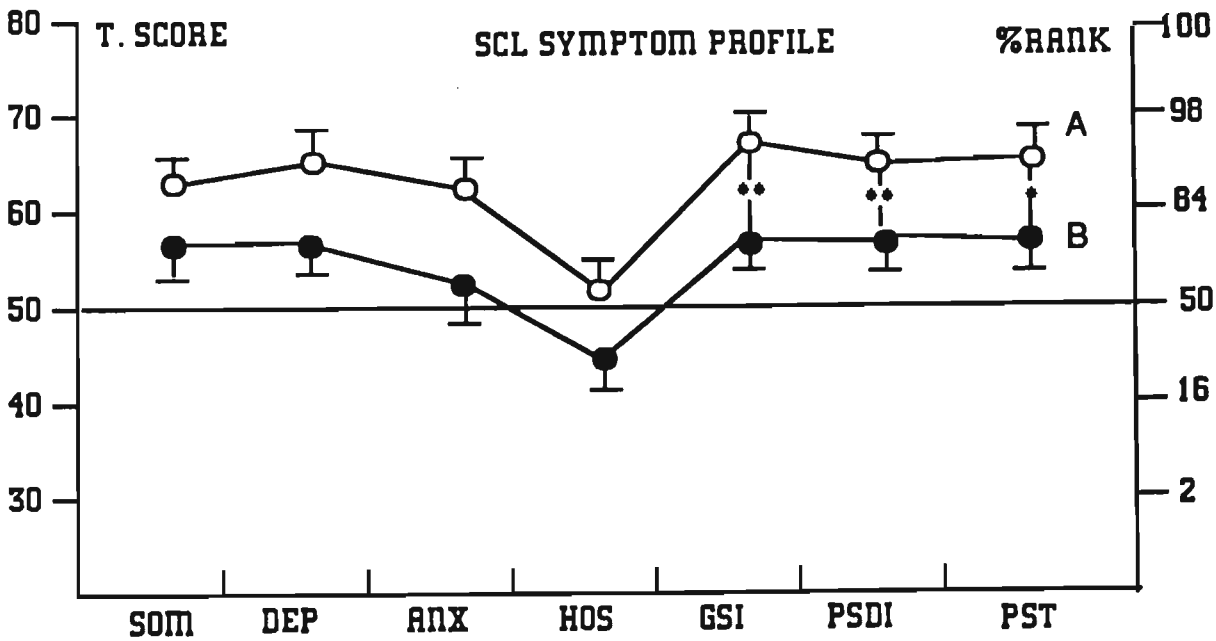

FIGURE II

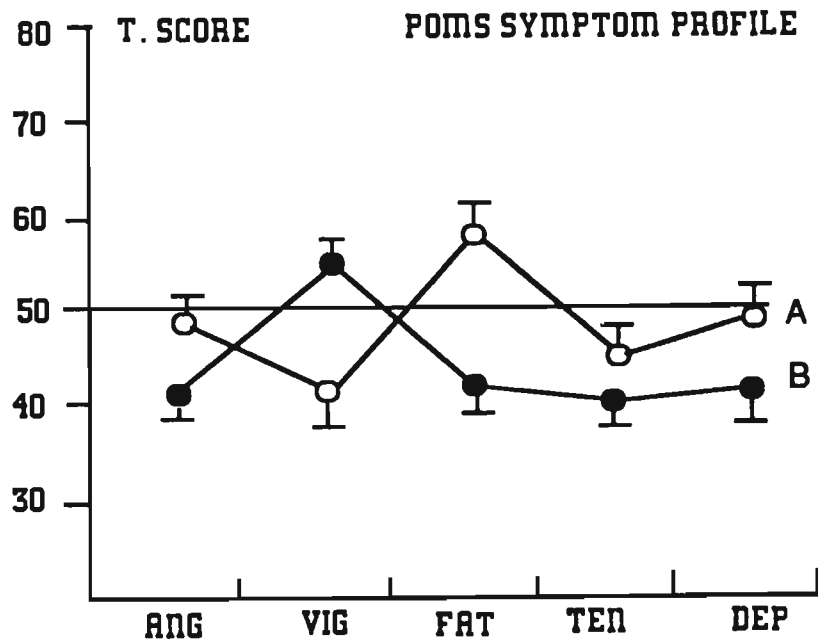
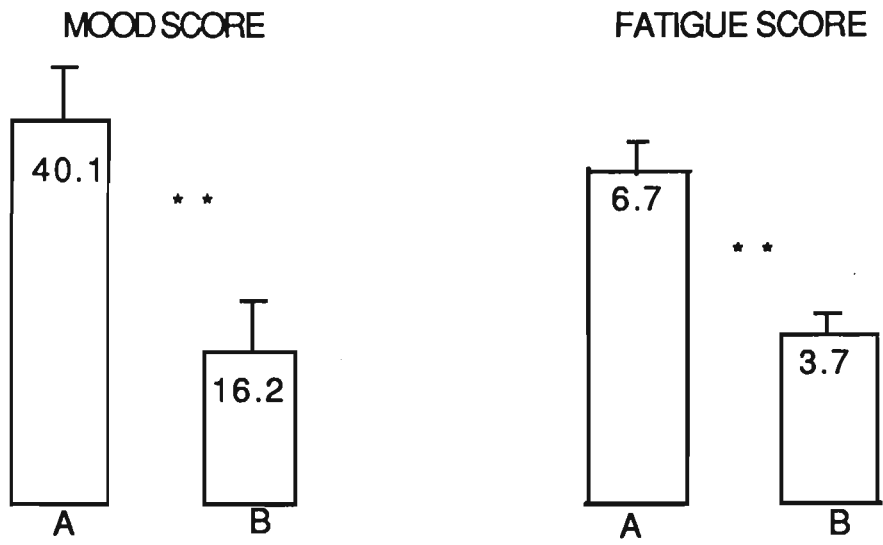

FIGURE III



SECTION 6 : SUMMARY AND CONCLUSIONS

CHAPTER 25 : SUMMARY AND CONCLUSIONS

I have endeavoured in this thesis to convey some of the nutritional problems endured by the brave and chiefly young patients with IBD. Clearly as a group these patients uniformly suffer from varying degrees of PEM together with its associated organ dysfunction . At the time of writing this thesis however, little was known of the nutritional status of the ambulatory patient with IBD, and confusion still existed over the long term nutritional changes following colectomy for colitis. Furthermore, despite there being experimental data to suggest that nutritional repletion (IVN) when given to these patients may result in an accumulation of muscle glycogen, an increase in body fat and possibly a slower accumulation of protein associated in these patients with a partial restoration of muscle fibre type, there was not a single randomised prospective trial indicating any primary therapeutic benefit from such treatment and nutritional therapy still remained contentious for this group of surgical patients.

In my first clinical study I described the body compositional data of a large group of patients presenting with different clinical presentations of IBD.

Unlike previous studies this was not dependent on inferences made from indirect measurements of nutritional status. Protein depletion was found to span a wide range of clinical presentations. Severe levels were present in those patients

presenting with acute exacerbations to hospital. The extra stress of a major surgical complication was found to result in further deterioration of the patients protein stores, resulting in a further deterioration in skeletal muscle function. Protein depletion was found not only to be confined to those patients suffering from acute illness but was also present in patients presenting for elective surgery. For the first time a persisting level of protein depletion was also found to be present in the ambulatory patient with IBD who was in clinical remission.

The situation for fully convalescent post-operative patients with colitis was found to be quite different. Contrary to previously published work discussed in the text, there was no evidence for either persisting protein depletion or water depletion in patients with either well functioning ileostomies or J-pouches.

In the second clinical study through the examination of the longitudinal changes in body composition in a group of patients undergoing J-pouch formation for ulcerative colitis covering at least a 12 month period, the timing and nature of this restorative process was clarified further. Twelve months later all the patients were in good health, back to work and had normally functioning pouches. Their stores of body protein and hydrational state had returned to normal limits although their body fat stores were increased. Over the post-operative period there were significant losses of weight, TBP, FFM and TBW. These had returned to pre-operative values (but not to normal) three months later. I concluded from this study that protein depleted patients with ulcerative colitis presenting for major surgery continue to have

distorted body composition for several months post-operatively but after 12 months or so when they feel well, contrary to previous reports (Cooper et al 1986, Turnberg et al 1978) their body composition has returned to normal.

Many authorities believe that patients with conventional ileostomies are chronically water and salt depleted (Clarke et al 1967b). The longitudinal data on patients following J-pouch suggested normal stores of water and salt but did not clarify the situation for ileostomy and whether the superior function of the J-pouch conferred any advantage over conventional ileostomy.

I attempted to clarify this observation in the 3rd study. The body composition of 14 patients with well functioning ileostomies and 20 patients with well functioning J-pouches together with their closely matched controls, was examined.

The results confirmed that the body contents of water and extracellular fluid in ileostomy patients and J-pouch patients were normal. The faecal volume and chemistry were similar in both groups resulting in a similar and significant degree of urinary retention.

This study was important as it clarified a previous misconception (Clarke et al 1967b). It also stresses that despite having demonstrated normal body stores of water and salt in these patients, both groups of patients remained still dependent on renal conservation mechanisms to compensate for their obligate faecal losses of salt and water. These compensatory mechanisms known to increase the incidence of renal calculi in ileostomy patients (Clarke et al 1967a) would therefore probably result in

similar problems in patients after J-pouch.

The risk of urinary stone formation was determined from the composition of their 24 hour urine samples.

The effect of ileostomy or J-pouch was found to significantly reduce urinary pH and volume consistent with their persistent faecal loss of water, sodium and bicarbonate. This reduced urine volume produces an increased concentration of urinary calcium, oxalate and uric acid. Both patient groups were found to have significantly increased relative supersaturations for both uric acid and calcium oxalate.

Interestingly the risk for calcium stone formation was not found to be increased in the J-pouch group. This was because the raised concentration of the calcium and oxalate were compensated by the lowered urinary pH, in the presence of near normal values of urinary GAGS.

Overall, there were few differences in the urinary chemistry between the two patient groups consistent with their similar faecal losses. One difference however was a higher urinary GAGS concentration in the J-pouch group which led to a reduction of the risk of calcium stone formation. Whether this would lead to an actual clinical difference in the respective incidences of kidney stones for these two patient groups remains to be seen.

In the last clinical section of this thesis the effect of a 14 day course of IVN was assessed in a group of patients suffering from severe exacerbations of IBD. In particular the effects on skeletal muscle function, respiratory muscle function, hepatosecretory function, wound healing and psychological function were examined

in addition to changes in body composition at the commencement of a 14 day course of IVN and 7 and 14 days later. Final measurements were made after recovery approximately 200 days later.

Compared to a group of matched controls the patients had lost approximately 35% of their body protein stores with accompanying physiological impairments of 20-40% and displayed high levels of psychological stress. After a few days of IVN there were improvements in all the physiological measurements (\sim 12%) A significant improvement to near normal levels of psychological distress and fatigue occurred , but no significant changes in total body protein. During convalescence there were further improvements in physiological function but these were accompanied by an increase in the body stores of protein, and as a consequence occurred over a longer time scale.

I concluded from these studies that there is an early rapid improvement in physiological function with IVN in patients hospitalised for acute exacerbations of IBD even though this is not accompanied by significant protein gain. Later during anabolic recovery physiological improvements occur in association with repletion of total body protein but this is a much slower process over many months.

It would appear from previous work (Windsor et al 1988a) that the magnitude of these improvements are probably sufficient to be clinically beneficial . It will be of considerable interest to see if similar or even more significant improvements accompany nutritional replenishment with an enteral diet.

What has this thesis meant to the busy clinician whose task it is to manage patients with IBD?

The thesis has clarified the following clinical areas:-

- 1) It re-affirms the high prevalence of PEM in patients presenting with acute exacerbations of IBD and establishes the existence of persisting protein deficits in patients even in clinical remission.
- 2) It illustrates the close relationship between protein depletion and physiological functional impairment.
- 3) It confirms that protein depleted patients with ulcerative colitis presenting for major surgery continue to have distorted body composition for several months post-operatively but after 12 months, body composition will be returned to normal.
- 4) It establishes that contrary to previous work patients with ileostomy and J-pouch do not have any whole body deficits of salt or water. Nevertheless these patients are still dependent on renal compensatory mechanisms which result in similar risks of forming renal calculi.
- 5) It establishes that nutritional support with IVN prevents further loss of total body protein. Furthermore within a few days of IVN respiratory muscle function, skeletal muscle function, hepatosecretory function, the wound healing response and psychological function will uniformly improve significantly but not to normal. Furthermore the magnitude of these improvements although incomplete is probably sufficient to be clinically beneficial.

Further improvement in function can only be associated with increases in the body stores of protein and is as a consequence a much slower process.

- 6) It highlights the need for new definitions of nutritional depletion and repletion by which we must assess the efficacy of future nutritional regimens in hospitalised patients with IBD.

REFERENCES

1. Abel R.M., Grimes J.B., Alonso D., et al
Adverse haemodynamic and ultrastructural changes in dog hearts subjected to protein-calorie malnutrition
Am. Heart. J. 1979; 97: 733-744
2. Aldrich T.K., Arora N.S., Rochester D.F.,
The influence of airway obstruction and respiratory muscle strength on maximum voluntary ventilation in lung disease.
Ann. Rev. Resp. Disease 1982; 126: 195-199
3. Anderson J., Osborn S.B., Tomlinson R.W.S., et al
Neutron activation analysis in man in vivo: a new technique in medical investigation
Lancet 1964; 2: 1201-1205
4. Ang S.D., Daly J.M.,
Potential complications and monitoring of patients receiving total parenteral nutrition,. In: Rombeau J.L., Caldwell M.D., eds Clinical Nutrition: Parenteral Nutrition
Philadelphia , Saunders 1986
5. Arora N.S., Rochester D.F.,
Respiratory muscle strength and maximal voluntary ventilation in undernourished patients.
Am. Rev. Resp. Disease. 1982; 126: 5-8
6. Axeleson C., Jarnum S.
Assessment of the therapeutic value of an elemental diet in chronic inflammatory bowel disease.
Scand. J. Gastroenterol 1977; 12: 89-95
7. Bambach C.P., Roberston W.G., Peacock M., Hill G.L.
The effect of intestinal surgery on the risk of urinary stone formation.
Gut 1981; 22: 257-263
8. Barot L.R., Rombeau J.L., Feurer B.S. et al
Caloric requirements in patients with Inflammatory Bowel Disease.
Ann. Surg. 1982; 195: 214-218
9. Bartlett R.H., Gazzaniga A.B., Geraghty T.R.,
Respiratory manoeuvres to prevent post-operative pulmonary complications : a critical review
JAMA 1973;; 224: 1017-1021
10. Beck J.M., Raymond J.L.
Ileal Pouch - Anal anastomosis
Ann Surg 1986; 204: 375-381

11. Beddoe A.H., Streat S.J. and Hill G.L.
Evaluation of an in vivo prompt gamma neutron activation facility for body composition studies in critically ill intensive care patients: results on 41 normals.
Metabolism 1984; 33: 270-280.
12. Beddoe A.H., Streat S.J., Hill G.L.
Hydration of the fat free body in protein depleted patients.
Am. J. Physiol 1985 a; 249: E227-E233
13. Beddoe A.H., Hill G.L.,
Clinical measurements of body composition using In vivo neutron activation analysis
JPEN 1985b; 9: 504-520
14. Beeken W.L.,
Remediable defects in Crohn's disease. A prospective study of 63 patients.
Arch Intern Med. 1975; 135: 686-90
15. Bennett R.C., Hughes E.S.R.,
Urinary calculi and ulcerative colitis
Br. Med. J. 1972; 2: 494-6
16. Best W.R., Becketl J.M., Singleton J.W. et al
Development of a Crohn's disease activity index
Gastroenterology 1976; 70: 439-444
17. Betzhold J. Howard I.
Enteral nutrition and gastrointestinal disease.
In Rombeau J.L., Caldwell M.D. (eds) Enteral and tube feeding.
Philadelphia W.B. Saunders 1984; 338-361
18. Bistrrian B.R., Blackburn G.L., Scrimshaw N.S et al
Cellular immunity in semi-starved states in hospitalised adults.
Am. J. Clin. Nutr. 1975; 28: 1148
19. Bistrrian B.R.,
Interaction of nutrition and infection in the hospital setting
Am. J. Clin. Nutr. 1977 a 30: 1228
20. Bistrrian B.R., Sherman M., Blackburn G.L. et al
Cellular immunity in adults marasmus.
Arch. Intern. Med. 1977 b; 137: 1408-1411
21. Black L.F., Hyatt R.E.
Maximal respiratory pressures: Normal values and relationships to age and sex.
Am. Rev. Resp. Dis 1969; 99: 696-702
22. Blackburn G.L., Bistrrian B.R., Maini B.S., Schlammm H.T., Smith M.F.

- Nutritional and metabolic assessment of the hospitalised patient
JPEN 1977; 1: 11-22
23. Bonneure O., Riis P., Anthonsien P.
Scand. J. Gastroenterol 1968; 3: 432
 24. Bolton R.P., Sherriff R.J., Read A.E.
Clostridium difficile associated diarrhoea: A role in
inflammatory bowel disease.
Lancet 1980; 1: 383
 25. Bos L.P., Weterman I.T.,
Total parenteral nutrition in Crohn's disease
World J. Surg. 1980; 4: 163-166
 26. Buckell N.A., Gould S.R., Hernandez N.A., et al
Direct method of measuring faecal protein loss in patients
with ulcerative colitis
Gut 1977; 18: A971
 27. Brown H.O., Levine M.L., Lipkin M.
Inhibition of intestinal Epithelial cell removal and
migration induced starvation.
Am. J. Physiol. 1963; 205: 868-72
 28. Burkinshaw L., Hill G.L., Morgan D.B.,
Assessment of the distribution of protein in human body by
in-vivo neutron activation analysis
IAEA-SM 1979; 227139: 787-797
 29. Burkland C.E., Rosenberg M.L.
Survey of urolithiasis in the United States
J. Urol 1955; 73: 198-207
 30. Buskirk E.R.,
Underwater weighing and body density: a review of
procedures. In Brozek J., Henschel A (eds)
Techniques for measuring body composition
Washington D.C.
 31. Buzby G.P., Mullen J.L., Matthews D.C. et al
Prognostic nutritional index in gastrointestinal surgery
Am. J. Surg. 1980; 139: 160
 32. Cave D.R., Mitchell D.N., Brooke B.N.
Induction of granulomas in mice by Crohn's disease tissue.
Gastroenterology 1978; 75: 632
 33. Chan S.T.F., McLaughlin S.J., Ponting G.A., Biglin J.,
Dudley H.A.F.,
Muscle power after glucose - potassium loading in undernourished
patients.
B.M.J. 1986; 293: 1055-1056

34. Cheek D.B.,
Estimation of the bromide space with a modification of Conway's
method.
J. Applied Physiol 1953; 5: 639
35. Christensen T., Bendix T., Kehlet H.,
Fatigue and cardio-respiratory function following abdominal
surgery.
Br. J. Surg. 1982; 69: 417-419
36. Christensen T., Kehlet H.
Post operative fatigue and changes in nutritional status
Br. J. Surg 1984; 71: 473-476
37. Christensen T., Wulff C.H., Fugslang-Fredericksen A.,
Kehlet H.,
Muscle force and electrical activity in post operative
fatigue
Acta Chir. Scand. (in press)
38. Christie P.M., Schroeder D., Hill G.L.,
Persisting superior mesenteric artery syndrome following
ileoanal J pouch anastomosis
Br. J. Surg. 1988 a; 75: 1036
39. Christie P. M., Hill G.L.,
Early improvement in skeletal muscle function following a
short course of intravenous nutrition
Aust. N.Z. J.Surg. 1988 b 230-231
40. Christie P.M., Knight G.S., Hill G.L.
Metabolism of body water and electrolytes after surgery
for ulcerative colitis conventional ileostomy versus
J-pouch
Br. J. Surg. 1990; 77: 149-151
41. Church J.M., Choong S.Y., Hill G.L.,
Abnormalities of muscle metabolism and histology in malnourished
patients awaiting surgery; effects of a course of intravenous
nutrition.
Br. J. Surg. 1984; 71: 563-569
42. Church J.M., Choong B.Y., Hill G.L.,
Abnormal muscle fructose biphosphatase activity in
malnourished cancer patients.
Cancer 1986; 58: 2449-2452
43. Clark A.H.,
The effect of diet on the healing of wounds
Bull Johns Hopkins Hosp. 1919; 30: 117
44. Clarke A.M., McKenzie R.G.
Ileostomy and the risk of urinary uric acid stones
Lancet 1967 a 2: 395-7

45. Clarke A.M., Chirnside A., Hill G.L.,
Chronic dehydration and sodium depletion in patients with
established ileostomies
Lancet 1967 b; 2: 740-743
46. Cohn S.H., Ellis K.J., Vartsky D et al
Comparison of methods of estimating body fat in normal
subject and cancer patients
Am J. Clin. Nutr. 1981; 34: 2839-2847
47. Cook C.D., Mead J., Orzalesi M.M.,
Static volume-pressure characteristics of the respiratory
system during maximal efforts
J. Appl. Physiol. 1964; 19 (5): 1016-1022
48. Cooper J.C., Laughland A., Gunning E.J., et al
Body composition in ileostomy patients with and without
ileal resection
Gut 1986; 27: 680-685
49. Crohn B.B.
Granulomatous diseases of the large and small bowel
A historical survey,
Gastroenterology 1967; 52: 767
50. Dean R.E., Campos M.M., Barrett B.
Hyperalimentation in the management of chronic inflammatory
intestinal disease
Dis. Colon Rectum 1976; 19: 601-604
51. Deane N., Ziff M., Smith H.W.,
The distribution of total body chloride in man
J. Clin. Invest. 1951; 31: 200-202
52. Deren J.J., Porush J.G., Levitt M.F., Khilnani M.T.,
Nephrolithiasis as a complication of ulcerative colitis
and regional enteritis
Ann Intern. Med., 1962; 56: 843-53
53. Derogatis L.R.,
SCL-90 - Administration, scoring and procedures Manual -I.
John Hopkins University School of Medicine 1974
54. Diament M.L., Palmer K.N.V.
Spirometry for pre-operative assessment of airways resistance
Lancet 1967; 1: 1251-1253
55. Dickenson R.J., Ashton M.G., Axon A.T.R., Smith R.C., Yeung C.K.,
Hill G.L.,
Controlled trial of intravenous hyperalimentation and total bowel
rest as an adjunct to the routine therapy of acute colitis
Gastroenterology 1980; 79: 1199-1204

56. Dobbins J.W., Binder H.J.,
Effects of bile salts and fatty acids on the colonic absorption
of oxalate
Gastroenterology 1976; 70: 1096-1000
57. Driscoll R.H., Rosenberg I.H.,
Total parenteral nutrition in inflammatory bowel disease
Medical Clin. North Am. 1978; 62: 185-201
58. Drongowski R.A., Coran A.G.,
Modification of the serum bromide assay for the measurement of
extracellular fluid volume in small subjects
Journal of Surgical Research 1982; 33: 423-426
59. Durnin J.V.G.A., Womersley J.
Body fat assessed from total body density and its estimation
from skinfold thickness; measurements on 481 men and women
aged from 16-72 years.
Br. J. Nutr. 1974; 32: 77-97
60. Dyer N.H., Dawson A.M.,
Malnutrition and malabsorption in Crohn's disease with
reference to the effect of surgery
Br. J. Surg. 1973; 60: 134-140
61. Edwards F.C., Truelove S.C.,
The course and prognosis of ulcerative colitis II long term
prognosis
Gut 1964; 4: 309
62. Edwards J.H.T., Young A., Hosking G.P.,
Jones D.A.,
Human skeletal muscle function; description of tests and
normal values.
Clin. Sci. 1977; 52: 283-290
63. Elson C.O., Layden T.J., Nemchausky B.A., Rosenberg J.L.
Roseberg I.H.,
An evaluation of total parenteral nutrition in the management
of inflammatory bowel disease.
Dig Dis. Sci. 1980; 25: 42-48
64. Elwyn D.H., Gump F.E., Munro H.N.,
Changes in nitrogen balance of depleted patients with
increasing infusions of glucose
Am. J. Clin. Nutr. 1979; 32: 1597-1611
65. Farmer R.G., Hawk W.A., Turnbull R.B.,
Clinical patterns in Crohn's disease. A statistical
study of 615 patients.
Gastroenterology 1975; 68: 627

66. Farmer R.G., Michener W.M., Mortimer E.A.,
Studies of a family history among patients with inflammatory
bowel disease.
Clin. Gastroenterol 1980; 9: 271
67. Fazio V.W., Kodner I., Jagelman D.G., Turnbull R.B.,
Weakly F.L.
Inflammatory disease of the bowel
Dis. Colon Rectum 1976; 19: 574-578
68. Fischer J.E., Foster G.S., Abel R.M., Abbott W.M. Ryan J.A.,
Hyperalimentation as primary therapy for inflammatory bowel
disease.
Am. J. Surg. 1973; 125: 165-175
69. Fleming C.R., McGill D.B., Berkner S.
Total parenteral nutrition as primary therapy in patients with
extensive Crohn's disease of small intestine and malnutrition
Gastroenterology 1977; 73: 1077-1081
70. Florent C., L'Hirondel C., Desmazes C., Giraudeau V.,
Bernier J.J.,
Evaluation of ulcerative colitis and Crohn's disease activity
by measurement of alpha-1-antitrypsin intestinal clearance.
Gastroenterol Clin Biol. 1981; 5: 193-197
71. Franklin J.L., Rosenberg I.H.,
Impaired folic acid absorption in inflammatory bowel disease
Effects of salicylazosulfapyridine (azulfidine)
Gastroenterology 1973; 64: 517-525
72. Frisancho A.R.,
New standards of weight and body composition by frame size and
height for assessment of nutritional status for adults and the
elderly.
Am. J. Clin. Nutr. 1984; 40: 808
73. Garibaldi R.A., Britt M.R., Coleman M.L., Reading J.C., Pace N.L.
Risk factors for post-operative pneumonia
Am. J. Med. 1981; 70: 677-680
74. Geigy
Scientific tables seventh edition 1975
75. Gelzayd E.A., Breuer R.I., Kirsner J.B.,
Nephrolithiasis in inflammatory bowel disease
Am. J. Dig. Dis. 1968; 13: 1027-1034
76. Gerlach K., Morowitz D.A., Kirsner J.B.,
Symptomatic hypomagnesemia complicating regional enteritis
Gastroenterology 1970; 59: 567-574
77. Gerson C.D., Fabry E.M.,
Ascorbic acid deficiency and fistula formation in regional

- enteritis
Gastroenterology 1974; 67: 428-433
78. Gerson C.D., Cohen N., Janowitz H.D.,
Small intestinal absorptive function in regional enteritis
Gastroenterology 1973; 64: 907-912
 79. Gilat T., Ribak J., Benaroya Y., Zemishlany Z., Weissman I.,
Ulcerative colitis in the Jewish population of Tel-Aviv Jafo I.
Epidemiology Gastroenterology 1974; 66: 335
 80. Gilat T., Rozen P.,
Epidemiology of Crohn's disease and ulcerative colitis;
etiologic implications
Isr. J. Med. Sci 1979; 15: 305
 81. Gitnick G.L., Rosen V.J., Arthur M.S., Hertwerk S.A.,
Evidence of the isolation of a new virus from ulcerative
colitis patients; comparison with virus derived from Crohn's
disease,
Dig. Dis.Sci. 1979; 24: 609
 82. Goligher J.C., De Dombal F.T., McKwatts J., Watkinson J.G.,
Ulcerative colitis.
London, Balliere Tindall Cassell 1968
 83. Goodson W.H., Hunt T.K.,
Developments of a new miniature method for the study of wound
healing in human subjects.
J. Surg. Res. 1982; 33: 394-401
 84. Grant J.P.,
Nutritional assessment in clinical practice.
Nutr. Clin. Pract. 1986; 1: 3-11
 85. Greenberg G.R., Fleming C.R., Jeejeebhoy K.N., Rosenberg I.H.,
Sales D., Tremaine W.J.,
Controlled trial of bowel rest and nutritional support in the
management of Crohn' disease
Gut 1988; 29: 1309-1315
 86. Harries A.D., Jones L.A., Heatley R.V., Rhodes J.
Malnutrition in inflammatory bowel disease; an anthropometric
study.,
Human Nutr. Clin. 1982; 36c: 307-313
 87. Harries A.D., Fitzsimmons E., Dew M.J., Heatley R.V., Rhodes J.
Association between iron deficiency anaemia and mid-arm
circumference in Crohn's disease.
Human Nutr. Clin. 1984; 38C: 47-53
 88. Harrison G.G., Van Italie T.B.,
Estimation of body composition a new approach based on

- electromagnetic principles
Am. J. Clin. Nutr. 1982; 32: 524-526
89. Harvey K.B., Ruggiero J.A., Regan C.S.
Hospital morbidity and mortality risk factors using nutritional
assessment.
Clin. Res. 1978; 76: 581A
90. Harvey K.B., Moldawer L.L. Bistrian B.R., et al.
Index for identifying and monitoring high risk patients
Clin. Res. 1979; 27: 571A
91. Harvey K.B., Moldawer L.L. Bistrian B.R., et al.
Biological measurements for the formulation of a hospital
prognostic index.
Am. J. Clin Nutr. 1981; 34: 2013
92. Haydock D.A., Flint M. H., Hill G.L.
Effects of intravenous nutrition on wound healing
Aust N.Z. J. Surg. 1984; 54: 169-170
93. Haydock D.A., Hill G.L.,
Impaired wound healing in surgical patients with
varying degrees of malnutrition
J. Parent. Ent. Nutr. 1986; 10: 550-554
94. Haydock D.A., Hill G.L.
Improved wound healing response in surgical patients
receiving intravenous nutrition
Br. J. Surg. 1987; 74: 320-323
95. Heatley R.V.,
Assessing nutritional state in inflammatory bowel disease
Gut 1986; 27, S1: 61-66
96. Heaton K.W.,
Disturbances of bile acid metabolism in intestinal disease.
Clin. Gastroenterol 1977; 6: 69-89
97. Hellberg R., Hulten L., Bjorn-Rasmussen E.,
The nutritional and haematological status before and after
primary and subsequent resectional procedures for classical
Crohn's disease and Crohn's colitis
Acta. Chir. Scand. 1982; 148: 453-460
98. Heuman R., Sjudahl R., Tobiasson C., Tagesson C.,
Post prandial serum bile acids in resected and non
resected patients with Crohn's disease.
Scan. J. Gastroent. 1982; 17: 137-140
99. Heymsfield S.B., Bethal R.A, Ansley J.D., et al.
Cardiac abnormalities in cachectic patients before and during
nutritional repletion.
Am.Heart. J. 1978; 95: 584-594

100. Hickman D.M., Miller R.A., Rombeau J.L., et al.
Serum albumin and body height as predictors of post operative course in colorectal cancer
JPEN 1980; 4: 314-316
101. Hill G.L., Blackett R.L., Pickford I., et al
Malnutrition in surgical patients - an unrecognised problem
Lancet 1977a; 1: 689-692
102. Hill G.L., Blackett R.L., Pickford I.R.,
Broadley J.A.
A survey of protein nutrition in patients with inflammatory bowel disease - a rational basis for nutritional therapy
Br. J. Surg. 1977b; 64: 894-896
103. Hill G.L., McCarthy I.D., Collins J.P., et al.
A new method for the rapid measurement of body composition in critically ill surgical patients.
Br. J. Surg. 1978; 65: 732-735
104. Hill G.L., Church J.M.
Energy and protein requirements of general surgical patients requiring intravenous nutrition
Br. J. Surg. 1984; 71: 1-9
105. Hill G.L., Goligher J.C., Smith A.H., Mair W.S.J.
Long term changes in total body water, total exchangeable sodium and total body potassium before and after ileostomy
Br. J. Surg. 1975; 62: 524-527
106. Hill G.L.
Ileoanal anastomosis with J pouch: an alternative to permanent ileostomy in ulcerative colitis and familial polyposis.
NZ Med. J. 1987; 100: 659-661
107. Hill G.L., Bouchier R.G., Witney G.B.,
Surgical and metabolic management of patients with external fistulas of the small intestine associated with Crohn's disease.
World. J. Surg. 1988; 12: 191-197
108. Hill G.L., Witney G.B., Christie P.M., Church J.M.,
Nutritional syndromes and the effect of intravenous nutrition (IVN) on protein nutriture - A prospective study of surgical patients with gastrointestinal disease.
Ann Surg. (in press)
109. Holter A.R., Fischer J.E,
The effects of perioperative hyperalimenatation on complications in patients with carcinoma and weight loss.
J. Surg. Res. 1977; 23: 31-34

110. Jackson M.J., Jones D.A, Edwards R.H.T.,
Experimental skeletal muscle damage; the nature of calcium
activated degenerative process.
Eur. J. Clin. Invest. 1984; 14: 369-374
111. Jacobson S., Kallner A.,
Effect of total parenteral nutrition on serum concentrations
of eight proteins in Crohn's disease.
Am. J. Gastroenterol 1984; 79: 501-505
112. Jeejeebhoy K.N.,
Muscle function and nutrition
Gut 1986; 27: 25-39
113. Jeejeebhoy K.N.,
Bulk or Bounce - The object of nutritional support
JPEN 1988; 12: 539-549
114. Johnson R.E.,
Techniques for measuring gas exchange
IN assessment of energy metabolism in health and
disease.
Kinney JM (ed)
Ross Laboratories, Columbus OH 1980; P32
115. Jones D.A., Jackson M.J., McPhail G., Edwards R.H.T,
Experimental mouse muscle damage; the importance of external
calcium
Clin. Sci. 1984; 66: 317-322
116. Kappogoda C.T., Stoker J.B., Linden R.J.,
A method for the continuous measurement of oxygen consumption
J. App. Physiol. 1974; 604-609
117. Kelly S.M., Rosa A., Field S., et al.
Inspiratory muscle strength and body composition in patients
receiving total parenteral nutritional therapy.
Am. Rev. Resp. Dis. 1984; 130: 33-37
118. Keys A., Brozek J., Henschel A., et al.
The biology of human starvation
Minneapolis, University of Minnesota Press 1950
119. Kiefer E.D.,
Recurrent regional ileitis.
Surg. Clin. North. Am. 1955; 35: 801-807
120. King R.F.G.J., Macfie J., Hill G.L.,
Activities of hexokinase phosphofructokinase, fructose
biphosphatase and 2 oxoglutarate dehydrogenase in muscle
of normal subjects and very ill surgical patients.
Clin. Sci. 1981; 60: 451-456

121. Klidjian A.M., Foster K.J., Kammerling R.M., et al.
Relation of anthropometric and dynamometric variables to serious post operative complications
Br. Med. J. 1980; 281: 899-901
122. Klidjian A.M., Archer T.J., Foster K.J., Karran S.J.,
Detection of dangerous malnutrition
JPEN 1982; 6,2: 119-121
123. Knight G.S., Beddoe A.H., Streat S.J, Hill G.L.,
Body composition of two human cadavers by neutron activation and chemical analysis
Am. J. Physiol. 1986; 250(endocrinal metab) 13: E179-E185
124. Krawitt E.L., Beeken W.L., Janney C.D.,
Calcium absorption in Chron's disease.
Gastroenterology 1976; 71: 251-254
125. Kushner R.F., Craig R.M.,
Intense nutritional support in inflammatory bowel disease.
A review
J. Clin. Gastroenterol 1982; 4: 511-520
126. Ladefoged K., Nicolaidu P., Jarnum S.,
Calcium, Phosphorus, Magnesium, Zinc and Nitrogen balance in patients with severe short bowel syndrome.
Am. J. Clin. Nutr. 1980; 33: 2137-2144
127. Laessle R.G., Schweiger U., Pirke K.M.,
Depression as a correlate of starvation in patients with eating disorders.
Biol. Psychiatry 1988; 23: 719-725
128. Lanfranchi G.A., Brignola C., Campieri M., et al.
Assessment of nutritional status in Crohn's disease in remission or low activity
Hepatogastroenterology 1984; 31: 129-132
129. Lehr L., Schobef O., Hundeshagen H., Pichlmayr R.,
Total body potassium depletion and the need for pre-operative nutritional support in Crohn's disease,
Ann. Surg. 1982; 196: 709-714
130. Lennard-Jones J.E., Longmore A.J., Newell A.C., Wilson C.W.F., and Jones F.A.,
An assessment of Prednisone salazopyrin and topical hydrocortisone used as out patient treatment for ulcerative colitis
Gut 1960; 1: 217
131. Lennard-Jones J.E., Misiewicz J.J., Connell A.M., Baron J.H., and Jones F.A.,
Prednisone as maintenance treatment for ulcerative colitis in

- remission.
Lancet 1965a; 1: 188
132. Lennard-Jones J.E., Connell A.M., Baron J.H., Jones F.A,
Controlled trial of sulphasalazine in maintenance therapy
for ulcerative colitis
Lancet 1965b; 1: 185
133. Lindstedt E., Sandblom P.
Wound healing in man: tensile strength of healing wounds
in some patient groups.
Ann. Surg. 1975; 181: 842-846
134. Lochs H., Egger-Schod L.M., Schuh R., et al.
Is tube feeding with elemental diets a primary therapy of
Crohn's disease?
Klin Wochenschr 1984; 62: 821-825
135. Lockhart-Mummery H., Morson B.,
Crohn's disease (regional enteritis) of the large intestine and
its distinction from ulcerative colitis
Gut 1960; 1: 87
136. Lohman T.G.,
Skinfolds and body density and their relation to body
fatness; A review
Hum. Biol. 1981; 25: 181-225
137. Lopes J., Russell D.M., Whitwell J., et al.
Skeletal muscle function in malnutrition
Am. J. Clin. Nutr. 1982; 36: 602-610
138. Lowe E. E., Stein M., Woolley T., et al.
Prognostic nutritional index, Usefulness as a predictor of
clinical course.
J. Am. Coll Nut. 1983; 2: 231
139. Macklem P.T.,
Muscular weakness and respiratory function
Editorial NEJM 1986; 315: 775
140. Main A.N.H., Mills P.R., Russell R.I., et al.
Mg deficiency in chronic inflammatory bowel disease and
requirements during intravenous nutrition
JPEN 1981; 5: 15-19
141. Main A.N.H., Mills P.R., Russell R.I., Bronte-Steward J.,
Nelson L.M., et al.
Vitamin A deficiency in Crohn's disease
Gut 1983; 24: 1169-1175
142. Maratka Z., Nedbal J.,
Urolithiasis as a complication of the surgical treatment

of ulcerative colitis
Gut 1964; 5: 214-217

143. Marshall R W., Robertson W.G .
Normograms for the estimation of the saturation of urine with calcium phosphate, magnesium ammonium phosphate, uric acid, sodium acid urate, ammonium acid urate and cystine.
Clin. Chim. Acta 1976; 72: 253-260
144. Matuchansky C.,
Parenteral nutrition in inflammatory bowel disease
Gut 1986; 27, S1: 81-84
145. McLaren D.S., Read W.W.C.,
Classification of nutritional status in early childhood.
Lancet 1972; 2: 146
146. McNair D.M., Lorr M., Droppleman L.F.,
Profile of mood states
San Diego; Educational and Industrial Testing Service
1971
147. McNeil N.I., Bingham S., Cole T.J., et al
Diet and health of people with ileostomy
Br. J. Nutr. 1982; 47: 407-415
148. Mekhjian H.S., Switz D.M., Melnyk C.S., Rankin G.B.,
Brooks R.K.,
Clinical features and natural history of Crohn's disease
Gastroenterology 1979; 77: 898-906
149. Meryn S., Lochs H., Pamperi H., Kleter D., Mulack K.,
Influence of parenteral nutrition on serum levels of proteins
in patients with Crohn's disease.
JPEN 1983; 7: 553-556
150. Metcalf A.M., Dozois R.R., Beart R.W. Jr., et al.
Temporary ileostomy for ileal pouch-anal anastomosis
Dis Colon Rectum 1986; 29: 300-303
151. Mitra S., Sutcliffe J.F., Hill G.L.,
A simple calibration for shadow shield counter for the
measurement of total body potassium in critically ill patients.
Phys. Med. Biol. 1988; 33:
152. Moore F.D.,
Metabolic care of the surgical patient
1959; Saunders, Philadelphia
153. Moore F.D., Olsen K.O., McMurray J.D., Parker H.V.,
Ball M.R., Boyden C.M.,
The body cell mass and its supporting environment
1963; Saunders Philadelphia

154. Morgan D.B., Hill G.L., Burkinshaw L.
The assessment of weight loss from a single measurements of
body weight: The problems and limitations
Am. J. Clin. Nutr. 1980; 33: 2110-2105
155. Morin C.L., Roulet M., Roy C.C., Weber A.,
Continuous elemental enteral alimentation in children with
Crohn's disease and growth failure.
Gastroenterology 1980; 79: 1205-1210
156. Mullen J.L., Hargrove W.C., Dudrick S.H., Fitts W.T. Jr.
Rosato E.F.,
Ten years experience with intravenous hyperalimentation and
inflammatory bowel disease.
Ann. Surg. 1978; 187: 523-529
157. Mullen J.L., Buzby G.P., Mathew D.C. et al
Reduction of operative morbidity and mortality by combined pre-
operative and post operative nutritional support.
Ann, Surg. 1980; 192: 604-613
158. Muller J.M., Brenner U., Dienst C., et al.
Pre-operative parenteral feeding in patients with
gastrointestinal carcinoma
Lancet 1982; 1: 68-71
159. Muller J.M., Keller H.W., Erasmi H., Pichlmaier H.,
Total parenteral nutrition as the sole therapy in Crohn's
disease - a prospective study
Br. J. Surg. 1983; 70: 40-43
160. Navarro J., Vargas J., Cezard J.P., Charritat J.L.,
Polonovski C.,
Prolonged constant rate elemental nutrition in Crohn's
disease.
J. Pediatr. Gastroenterol Nutr. 1982; 1: 541-546
161. Nyhlin H., Dyckner T., Ek B., Wester P.O.,
Magnesium in Crohn's disease
Acta Med. Scand. Suppl. 1982; 66: 21-25
162. Nyman M., Hansson I., Eriksson S.,
Long term immunosuppressive treatment in Crohn's disease.
Scand. J. Gastroenterol 1985; 20: 1197
163. O'Donaghue D.P., Dawson A.M., Powell-Tuck J.,
Bowen R.I., Lennard-Jones J.E.,
Double blind withdrawal trial of azathioprine as maintenance
treatment for Crohn's disease.
Lancet 1978; 2: 955
164. O'Morain C., Segal A.W., Levi A.J.,
Elemental diets in treatment of acute Crohn's disease
Br. Med. J. 1980; 281: 1173-1175

165. O'Morain C., Segal A.W., Levi A.J.,
Elemental diet as primary treatment of acute Crohn's
disease: A controlled trial
Br. Med. J. 1984; 288: 859-862
166. Ostro M.J., Greenberg G.R., Jeejeebhoy K.N.,
Total parenteral nutrition and complete bowel rest in the
management of Crohn's disease.
JPEN 1985; 9: 280-287
167. Pace N., Rathbun E N.,
Studies on body composition III. The body water and
chemically combined nitrogen content in relation to the
fat content.
J. Biol. Chem. 1945; 158: 685-691.
168. Parkinson I.S., Sheldon W.L., Laker M.F., Smith P.A.,
Critical evaluation of a commercial enzyme Kit (sigma)
for determining oxalate concentrations in urine.
Clin. Chem 1987; 33/7/: 1203-1207
169. Pena A.S., Biemond I., Kuiper G., Weterman I.T.,
Van Leeuwen A., Schneuder I., Van Rood J.J.,
HLA antigen distribution and HLA haplotype segregation in
Crohn's disease.
Tissue antigens 1980; 16: 56
170. Pettigrew R.A., Hill G.L.,
Indications of surgical risk and clinical judgement
Br. J.Surg. 1986; 73: 47-51
171. Pollack S.V.,
Wound healing : a review III. Nutritional factors
affecting wound healing.
J. Dermatol. Surg. Oncol. 1979; 5: 615
172. Powell-Tuck J., Garlick P.J., Lenhard-Jones J.E.,
Waterlow J.C.,
Rates of whole body protein synthesis and breakdown increased
with the severity in inflammatory bowel disease.
Gut 1984; 25: 460-464
173. Presta E., Segal K.R., Gutin B. et al.
Comparison in man of total electrical conductivity and lean body
mass derived from body density: validation of a new body
composition method.
Metabolism 1983; 32: 524-526
174. Rainey-MacDonald C.G., Holiday R.L., Wells G.A., et al
Validity of a two-variable nutritional index for use in
selecting candidates for nutritional support.
JPEN 1983; 7; 15-20

175. Reilly J., Ryan J., Strole W., Fischer J.E.,
Hyperalimentation in inflammatory bowel disease
Am. J. Surg. 1976; 131: 192-200
176. Report on the Task Group on Reference Man, Int Comm
Radiol. Protection report. no 23, Oxford. Pergamon press 1975
177. Rhodes J., Rose J.,
Does food affect acute inflammatory bowel disease. The role
of parenteral nutrition, elemental and exclusion diets.
Gut 1986; 27: 471-4
178. Robertson W.G., Peacock M., Heyburn P.J., Marshall D.H.,
Clark P.B.,
Risk factors in calcium stone disease of the urinary tract
Br. J. Urol. 1978; 50: 449-454
179. Rocchio M.A., Cha C.M., Haas K.F., Randall H.T.,
Use of chemically defined diets in the management of patients
with acute inflammatory bowel disease.
Am. J. Surg. 1974; 127: 469-475
180. Rochester D.F.,
Respiratory muscle function in health.
Heart and Lung 1984 a 13: 349-354
181. Rochester D.F., Esau S.A.,
Malnutrition and the respiratory system
Chest 1984 b; 85: 411-415
182. Rosenberg I.H., Bengoa J.M., Sitrin M.D.,
Nutritional aspects of inflammatory bowel disease
Ann. Rev. Nutr. 1985; 5: 463-484
183. Rossen R.D.,
HLA and disease. A postulated role for HLA in gastrointestinal
diseases.
Gastroenterology 1980; 78: 1629
184. Russell D.McR., Jeejeebhoy K.N.,
The assessment of the functional consequences of malnutrition
Nutritional abstracts and reviews.
Clinical Nutritional Series A. 1983 a; 53: 863-877
185. Russell D. McR, Leiter L.A., Whitwell J., Marliss E.B.,
Jeejeebhoy K.N.,
Skeletal muscle function during hypocaloric diets and fasting:
A comparison with standard nutritional assessment parameters
Am. J. Clin Nutr. 1983b; 37: 133-138
186. Russell D. McR., Prendergast P.J., Darby P.L., Garfinkel P.E.,
Whitwell J., Jeejeebhoy K.N.
A comparison between muscle function and body composition in

- anorexia nervosa: the effect of refeeding
Am. J. Clin. Nutr. 1983c; 38: 229-237
187. Russell D. McR., Walker P.M., Leiter L.A.,
Metabolic and structural changes in skeletal muscle during
hypocaloric dieting.
Am. J. Clin. Nutr, 1984; 39: 503-513
188. Scott R., Freeland R., Mowat W., Gardiner M., Hawthorne V.,
Marshall R.W., Ives J.G.J.,
The prevalence of calcified upper urinary tract stone disease
in a random population
Cumbernauld Health Survey
Br. J., Urol 1977; 49: 589-595
189. Singleton J.W., Law D.H., Kelly M.L.Jr. Mekhjian H.S.,
Sturdevant R.A.L.,
National cooperative Crohn's disease study; Adverse
reactions to study drugs.
Gastroenterology 1979; 77: 870
190. Siri W.E.,
University of California Radiation Laboratory Publication
1956; No 3349
191. Smith A.M., (1965) PhD thesis, University of Leeds
192. Smith L.H.,
Application of physical, chemical and metabolic factors to
the management of urolithiasis.
Urolithiasis research. New York and London. Premium Press
1976; 199-211
193. Smolen J.S., Gangl A., Polteraer P., Menzel E.J., et al

Gastroenterology 1982; 82: 34
194. Solomons N.W., Rosenberg I.H., Sandstead H.H.,
Vo-Khactu K.P.,
Zinc deficiency in Crohn's disease
Digestion 1977; 16: 87-95
195. Souba W.W., Smith R.J., Wilmore D.W.,
Glutamine metabolism by the intestinal tract
JPEN 1985; 9: 608-617
196. Stewart A.L.,
The reliability and validity of self reported weight and
height
J. Chron. Dis. 1982; 35: 295-309
197. Streat S.J., Beddoe A.H., Hill G.L.,
Measurement of body fat and hydration of the fat-free body in

health and disease
Metabolism 1985; 34: 508-518

198. Studley H.O.,
Percentage of weight loss. A basic indicator of surgical risk
in patients with chronic peptic ulcer
JAMA 1936; 106: 458-460
199. Summers R.W., Switz D.M. Sessions J.T., Bectel J.M.,
Best W.R., Kern F.Jr., Singleton J.W.,
National cooperative Crohn's disease study: results of drug
treatment.
Gastroenterology 1979; 77: 847
200. Superina R., Meakins J.L.,
Delayed hypersensitivity, anergy and the surgical patient
J.Surg. res. 1984; 37: 151-174
201. Swarbrick E.J., Kingham J.G.C., Price H.L., Blackshaw A.J.,
Griffiths P.D., Darougar S., Buckell N.A.,
Chlamydia , cytomegalovirus and Yersinia in inflammatory
bowel disease.
Lancet 1979; 2: 11
202. Taylor-Robinson D., O'Morain C.A., Thomas B.J., Levi A.J.,
Low frequency of chlamydial antibodies in patients with
Crohn's disease and ulcerative colitis.
Lancet 1979; 1: 1162
203. Town M.H., Gelm S., Hammer B., Ziegenhorn J.,
A sensitive calorimetric method for the enzymatic determination
of uric acid.
J. Clin. Chem. Clin Biochem 1985; 23: 591
204. Trnka Y.M., Lamont J. T.,
Association of clostridium difficile toxin with symptomatic
relapse of chronic inflammatory bowel disease.
Gastroenterology 1981; 80: 693
205. Truelove S.C., Witts., L.J.,
Coricosone in ulcerative colitis
Report on therapeutic trial
Br. Med. J. 1955; 2: 1041
206. Truelove S.C., Witts L.J.,
Corisone and corticotropin in ulcerative colitis
Br. J. Med. 1959; 1: 387
207. Turnberg L.A., Morris A.I., Hawker P.C., Herman K. J.
Shields R.A., North C.E.,
Intracellular electrolyte depletion in patients with
ileostomies
Gut 1978; 19: 563-568

208. Van Patter W.N., Bargaen J., Dockerty M.B., Feldman W.H., Mayo C.W., Waugh J.M.,
Regional enteritis.
Gastroenterology 1954; 26: 347-450
209. Vogel C.M., Corwin T.R., Baue A.E.,
Intravenous hyperalimentation in the treatment of inflammatory
bowel diseases of the bowel.
Arch. Surg. 1974; 108: 460-467
210. Voigt A.J., Echave V., Feller J.H., Brown R.A., Gurd F.N.
Experience with elemental diet in the treatment of inflammatory
bowel disease.
Arch. Surg. 1973; 107: 329-333
211. Ward M.W.N., Danzi M., Lewin R.M., Rennie M.J., Clark C.G.,
The effect of sub clinical malnutrition and refeeding on the
healing of experimental colonic anastomosis.
Br. J. Surg. 1982; 69: 308-310
212. Waterlow J.C., Jackson A.A.,
Nutrition and protein turnover in man.
Br. Med.J. 1981; 37: 5-10
213. Weeke B., Jarnum
Serum concentration of 19 serum proteins in Crohn's disease
and ulcerative colitis
Gut 1971; 12: 297-302
214. Westin T., Jansson A., Zenckert C., et al
Mental depression is associated with malnutrition in patients
with head and neck cancer,
Arch. Otolaryngol Head Neck Surg. 1988; 114: 1449-1453
215. Whitehead R.,
Pathology of Crohn's disease. In Kirsner J.B., Shorter R.G., (eds)
Inflammatory bowel disease Ed 2, Philadelphia.
Lea and Febiger 1980; 296-310
216. Whitman P.,
The quantitative determination of glycosaminoglycans in urine
with Alcian blue 8GX
Biochem J. 1973; 131: 351-357
217. Whitney C.B., Streat S.J., Hill G.L.,
Classification of surgical malnutrition : a new approach
of clinical relevance.
Aust NZ J. Surg. 1978; 57: 260
218. Wilks S., Moxon W.,
Lectures on pathological anatomy
2nd Ed, London J. A Churchill 1875

219. Williams R.H.P., Heatley R.V. , Lewis M.H., et al
Preoperative parenteral nutrition in patients with stomach
cancer. In Baxter D.H., Jackson G.M., (eds)
Clinical parenteral nutrition, Chester, England
Geistlich education 1977: 52-59
220. Williams W.J.,
Histology of Crohn's disease
Gut 1964: 5: 510
221. Windsor J.A., Hill G.L.,
Does organ dysfunction occur in protein depleted pre-operative
patients.
Aust NZ J. Surg. 1986; 56: 257
223. Windsor J. A., Hill G.L.
Weight loss with physiological impairment as a basic indicator
of surgical risk.
Ann., Surg. 1988a: 207: 209-296
224. Windsor J.A., Hill G.L.,
Grip strength : A sensitive measure of body protein loss in
surgical patients
Br. J. Surg. 1988b In press
225. Windsor J.A., Hill G.L.,
Risk factors for post-operative pneumonia
Ann. Surg. 1988c; 208: 209-214
226. Windsor J.A., Knight G.S. Hill G.L.,
Wound healing response in surgical patients ; recent food
intake is more important than nutritional status
Br. J. Surg. 1988d; 75: 135-137
- 227, Wolman S.L., Anderson G.H., Marliss E.B., Jeejeebhoy K.N.,
Zinc in total parenteral nutrition; requirements and metabolic
effect
Gastroenterology 1979; 76: 458-467
228. Yeung C.K., Smith R.C., Hill G.L.
Effect of an elemental diet on body composition ; A comparison
with intravenous nutrition
Gastroenterology 1979; 77: 652-657
229. Young G.A., Hill G.L.
Assessment of protein calorie malnutrition in surgical patients
from plasma proteins and anthropometric measurements
Am J. Clin. Nutr. 1978; 31: 429-435
230. Young G.A., Hill G.L.
Evaluation of protein energy malnutrition in surgical patients
from plasma valine and other amino acids, proteins and
anthropometric measurements.
Am. J. Clin. Nutr. 1981; 34: 166-172